

PUSHOVER ANALYSIS OF A MODERN AGGREGATE OF MASONRY BUILDINGS THROUGH MACRO-ELEMENT MODELLING

Marques, Rui¹; Vasconcelos, Graça²; Lourenço, Paulo B.³

¹ MSc, PhD Student, University of Minho, Department of Civil Engineering, marquesmnc@sapo.pt

² PhD, Assistant Professor, University of Minho, Department of Civil Engineering, graca@civil.uminho.pt

³ PhD, Professor, University of Minho, Department of Civil Engineering, pbl@civil.uminho.pt

The masonry building aggregates are a typology of construction typical of historical town centres, where a complex structural system with longitudinal and transversal walls is arranged at different ground and roof levels. Currently, the recuperation of the masonry as a structural solution will depend, in significant part, on its use in the construction of housing blocks, which can present many of the features of a typical building aggregate. The behaviour of this construction typology should be assessed under seismic loads, since it has been shown to be vulnerable to such type of loading. In this work, the case of a modern aggregate of masonry buildings, which is constituted by adjacent buildings at different levels, is studied under simulated seismic loading through nonlinear static (pushover) analysis on a macro-element model idealized for the aggregate. A developed concrete block masonry system is adopted as the structural solution. The aggregate is evaluated regarding its seismic performance by considering three different configurations: a set of dwellings with independent behaviour, a levelled conglomeration of buildings, and an unlevelled aggregate. A comparison between the predicted performances of solutions with unreinforced and truss type horizontally reinforced masonry is made in terms of both base shear-displacement response and damage pattern. The main conclusions are that the structural irregularity in elevation implies loss of displacement capacity, and that the horizontal truss reinforcement allows only qualitatively an improvement of the structural ductility, given a more distributed damage and a higher deformation capacity.

Keywords: Modern masonry, structural irregularity, pushover analysis, macro-element modelling, truss reinforcement

INTRODUCTION

In recent years, research on structural masonry has devoted to two kinds of constructions, the existing and the new masonry buildings. In the first case, buildings have been studied both as isolated structures and as building aggregates, since this last is the most common typology in the urban mesh of old cities. Modern masonry is an emergent topic, to which significant research has been devoted, namely to develop new masonry systems with improved functional and particularly mechanical properties for earthquake-resistance. The clay brick “CBloco” (Lourenço et al., 2008; Lourenço et al. 2010) and the concrete block “Costa & Almeida” (Mosele et al., 2006) in Figure 1 are examples of these systems, which have been developed at University of Minho, Portugal, in cooperation with the Industry.

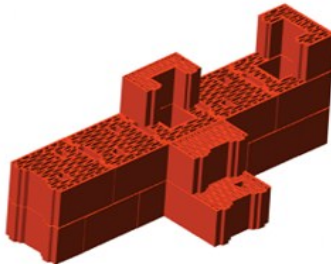

Figure 1: Illustrations of the CBloco and Costa & Almeida masonry systems

However, studies regarding the earthquake-resistant construction of new masonry buildings have been performed on a low scale, the higher at the level of dwelling houses. By this, the current state-of-art on the seismic behaviour of modern masonry seems to allow only the construction of small houses on flat ground. This is the case of typical low-height buildings (Figure 2a) constructed in countries such as Germany. The expansion of urban areas requires however, in most cases, construction with irregular configurations, particularly of building conglomerations on sloped ground, such as in Figure 2b for a block of r.c. buildings.



(a)



(b)

Figure 2: Urban expansion through (a) low-height masonry dwellings and (b) medium-height masonry buildings

Sustainability in construction at the urban scale requires the consideration of the masonry as a potential structural solution in the construction of medium-height buildings, as occurred in the past, particularly for the case of low-to-medium seismicity regions. By this reason, in this study a contribution to understand the seismic behaviour of both regular and irregular building conglomerations of modern masonry buildings is attempted. To accomplish this goal, a block of dwelling houses is modelled through a simplified approach to perform pushover analysis regarding the performance-based safety verification. A brief description of the used modelling approach is made, and a case study with results supporting some evidences and conclusions for the seismic conception and design of masonry building conglomerations is presented.

MODELLING OF MASONRY BUILDINGS

In this work, the modelling of masonry buildings has been made through a macro-element approach idealized by Gambarotta and Lagomarsino (1996). The used macro-element allows with 8 d.o.f. and a static-kinematic approach (Figure 3) to model the two main in-plane failure modes, the bending-rocking by a mono-lateral elastic contact between the extremity layer interfaces and the shear-sliding by considering a uniform shear deformation distribution on the central layer.

For the case of the bending-rocking mechanism, the panel strength is computed assuming a rectangular stress block for the masonry in compression, through the formula in Figure 4a. The shear failure is assumed by sliding shear according to the Mohr-Coulomb approach in Figure 4b or by diagonal cracking when the principal tensile stress at the centroid of the panel reaches the tensile strength of the masonry, according to the Turnšek and Čačovič (1970) criterion in Figure 4c. For the response of the panel an elastic–perfectly plastic (bilinear) law is assumed, which is an approximation to the envelope of lateral cyclic loading tests on masonry panels, where the ultimate drift is associated to a given strength degradation.

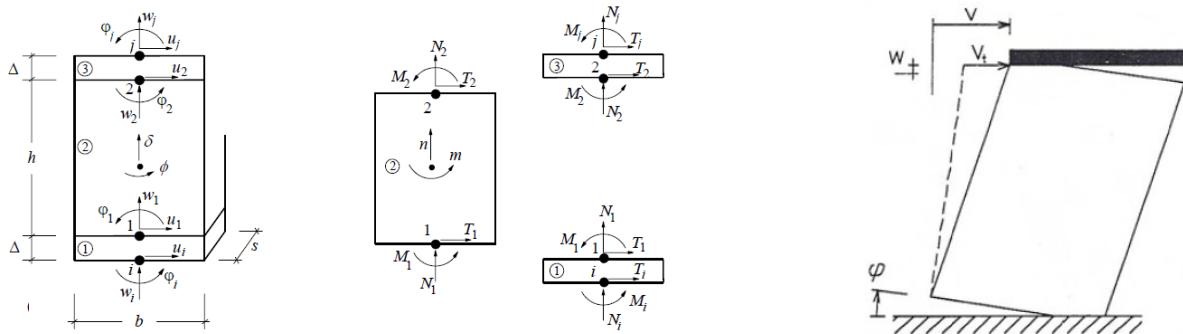

Figure 3: Kinematic model for the macro-element (Gamborotta and Lagomarsino, 1996)

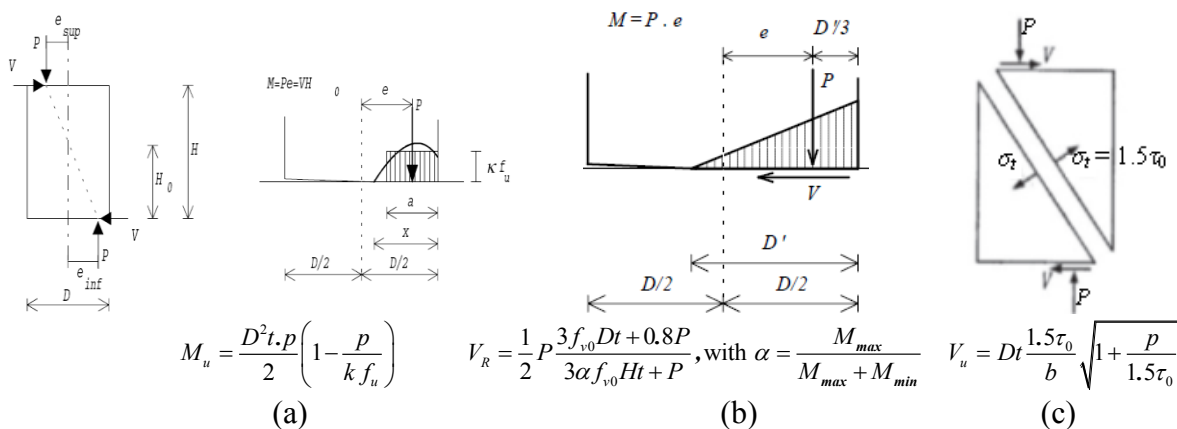

Figure 4: Criteria for the panel strength to: (a) bending-rocking, (b) sliding shear and (c) diagonal shear

The building modelling is based on the discretization of the walls in macro-elements, which are representative of pier-panels and lintels contiguous to the openings (Figure 5a). The connection between the piers and lintels is made through rigid nodes, which are representative of portions of masonry typically undamaged during seismic actions. 3D nodes with 5 d.o.f. are used to allow the structural equilibrium between transversal walls (Figure 5b). The walls are the bearing elements, while floors, apart from sharing vertical loads to the walls, are considered as plane stiffening elements (orthotropic 3-4 nodes membrane elements), on which the distribution of horizontal actions between the walls depends. The local flexural behaviour of the floors and the out-of-plane response of walls are not computed because they are considered negligible with respect to the global building response, which is governed by their in-plane behaviour (Lagomarsino et al., 2009).

In this work, the computation of the effective height of piers was inspired on the Dolce (1991) rule, which bases in the cracking propagation with a slope of 30° from the opening corners and accounts for the effective slenderness of piers according to:

$$\bullet \quad H_{\text{eff}} = \frac{H' + D(I - H')}{3H'} \leq I \quad (1)$$

where H' is the distance between the midpoints of segments that connect corresponding corners of adjoining openings and I is the inter-storey height.

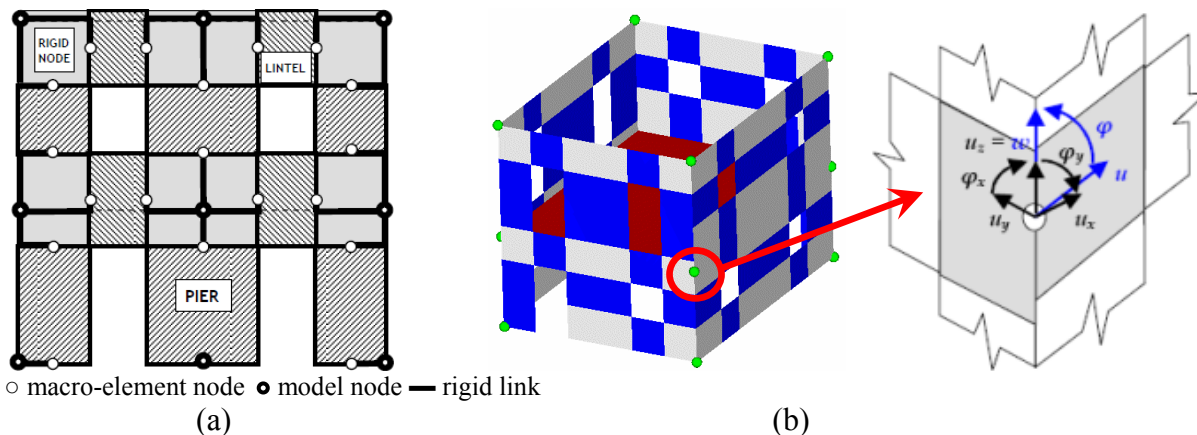

Figure 5: Wall discretization and tridimensional assemblage of a building

CASE STUDY

The case study presented here is a masonry building aggregate with three conglomerated 2-storey dwellings. The dwellings, presented in Figure 6, are positioned in a mirrored form and each one unlevelled from the previous about half-storey (1.40 m). The walls are made with the concrete block system “Costa & Almeida” by using the traditional masonry bond, which implies modular dimensions multiple of 20 cm both in plan and elevation. A rigid slab of 30 cm thickness boarded with r.c. ring beams covers each storey, spanning 80% of its weight (from a total of 8.0 kN/m² dead more 0.3×2.0 kN/m² live loads) in the smallest dimension.

The two main aspects to be captured from the pushover analysis (with inverted triangular fashion) are the block effect and the change in the building response due to the unlevelling, respectively in comparison with the behaviour of an isolated dwelling and of a levelled conglomeration. The macro-element models, built in the TreMuri program research version (Lagomarsino et al., 2009), corresponding to the three considered building configurations are presented in Figure 7, which main façade macro-element models are presented in Figures 8 and 9.

The considered properties for the masonry material, based both on experimental results and code recommendations, are a weight w of 13.0 kN/m³, a compressive strength f_m of 5.0 MPa, a pure shear strength f_{v0} of 0.25 MPa, an elastic modulus E of 5000 MPa, a shear modulus G of 2000 MPa, a flexural limit drift δ_f of 0.8% and a shear limit drift δ_s of 0.4%. Regarding the improvement of the building response, use of truss reinforcement in bed joints with 5 mm



diameter longitudinal bars of steel S550 has been also considered in the modelling, the reinforced panels presenting 0.6% and 1.2% limit drifts respectively for shear and flexure.

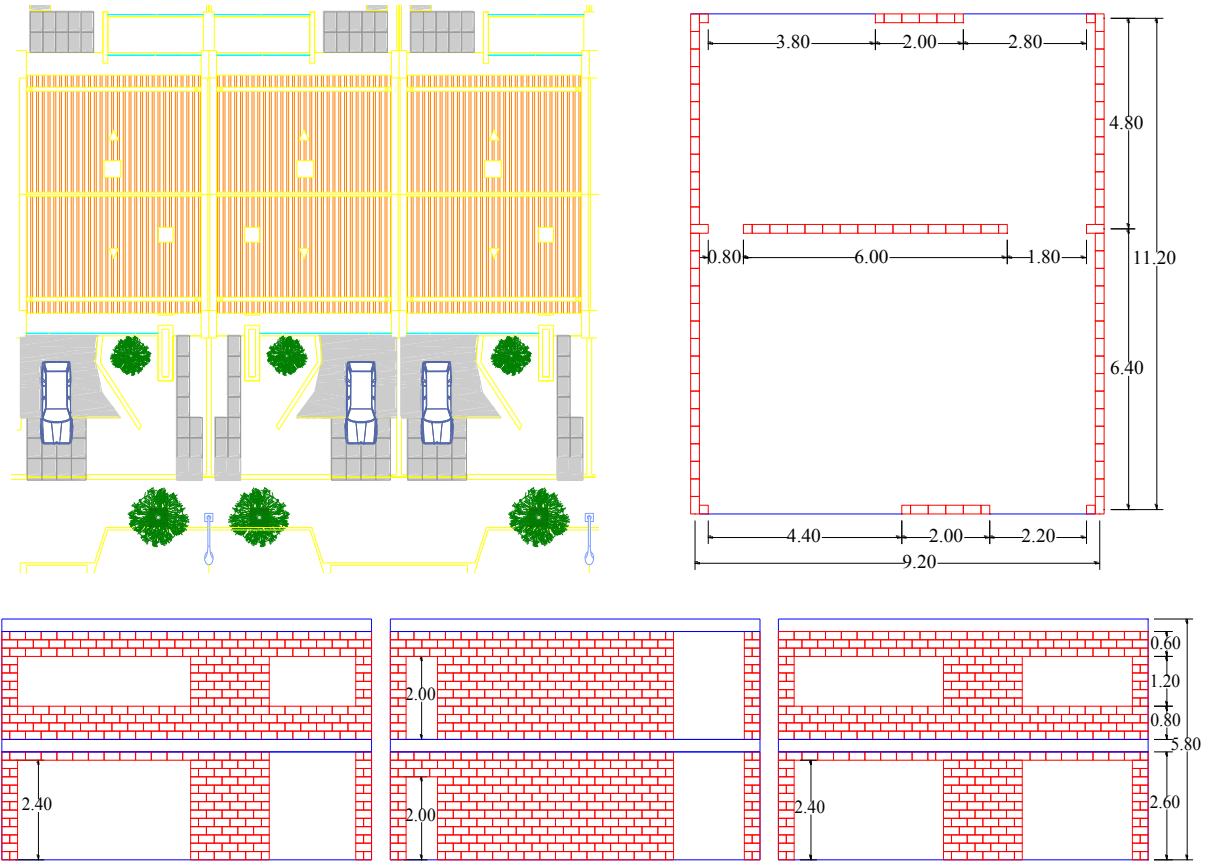

Figure 6: Plan and elevations of the dwelling houses

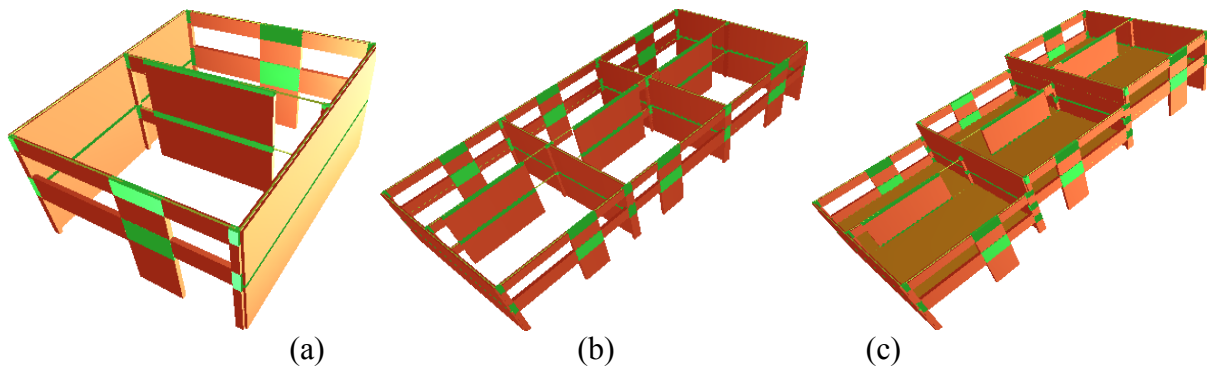

Figure 7: Macro-element models of the (a) isolated dwelling, (b) levelled conglomeration and (c) unlevelled conglomeration

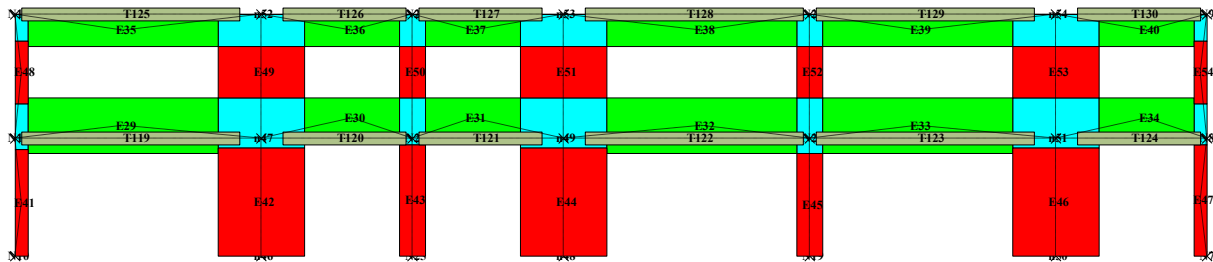

Figure 8: Main façade macro-element model of the levelled conglomeration

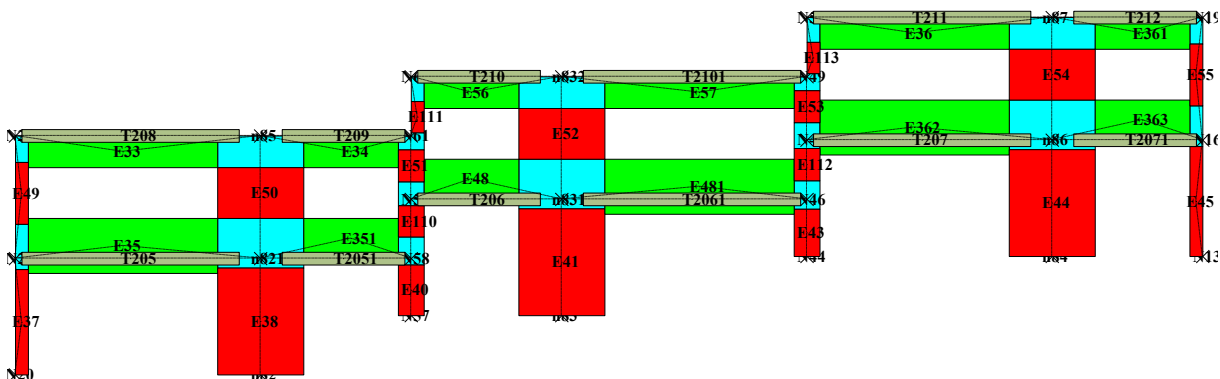

Figure 9: Main façade macro-element model of the unlevelled conglomeration

RESULTS

A series of analyses was first carried out to predict the seismic response of an isolated dwelling, to be used after as reference in the evaluation of the response of the building aggregates, considering both Mohr-Coulomb (M-C) and Turnšek-Čačovič (T-Č) shear criteria, and a bed joint truss reinforcement (b.j.t.r.) with 5 mm diameter truss spaced of 2-3 courses (d5@40-60cm). Note that M-C and T-Č shear criteria are considered as boundary cases for the shear behaviour, given that the first is associated to the development of stair stepped cracks through the unit-mortar interface, and the second engage relates mainly to diagonal cracking through masonry joints and units. Nevertheless, in practice a mixed pattern is typically observed (e.g., Gouveia and Lourenço (2007)). The ultimate damage on the two representative walls of the isolated house for both loading signs is presented in Figure 10, the corresponding capacity curves appearing in Figure 11.

The response of the isolated dwelling in correspondence with the M-C shear criterion is mainly governed by the shear failure of the longest panels, the external piers failing by flexure. For the rightward loading a first storey mechanism is identified, whereas in leftward direction the mechanism occurs in the second storey induced by the flexural failure of a spandrel in the main wall. When considering the T-Č shear criterion, the strength of the building is governed by a flexural damage mechanism which provides higher base shear and displacement capacities. In both loading directions a second storey mechanism is being detected. Note that the building response can be strongly changed according to the considered shear failure mode/criterion, as denoted from the rightward loading with a verified alteration of the deformed shape (left side of Figure 10a-b).

Note that for the case in which truss reinforcement in bed joints is considered, an improved sliding shear strength is computed for the pier panels according to Penna et al. (2007):

$$\bullet \quad V_R = f_v D' t + f_y A_{sh} l' / s \leq f_v D t \quad (2)$$

where f_v is the masonry shear strength computed by a M-C criterion, D is the wall length, D' is the compressed length of the wall, f_y is the steel yield strength, A_{sh} is the area of the cross section of the b.j.t.r. and s its vertical spacing, H is the wall height and $l' = \min(D', H)$. In this case T-Č shear criterion is discarded, as the reinforcement induces mainly sliding and shear failure by localized diagonal crack should not occur.

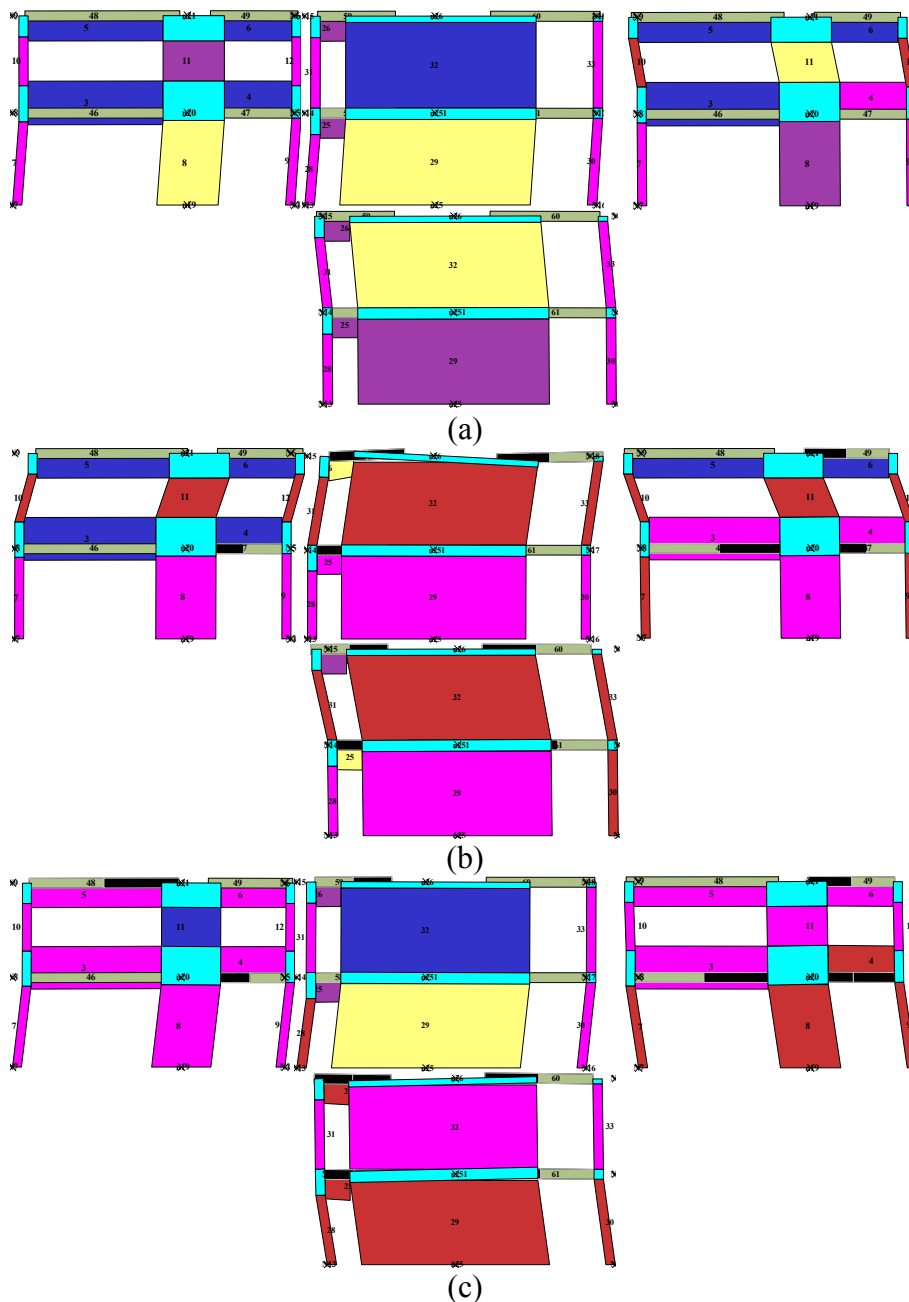

undamaged
 Shear cracking
 Shear failure
 Flexural damage
 Bending failure
 tension

Figure 10: Final damage of the isolated dwelling on the main and central walls for both loading signs considering (a) M-C and (b) T-Č shear criteria, and (c) d5@40cm b.j.t.r.

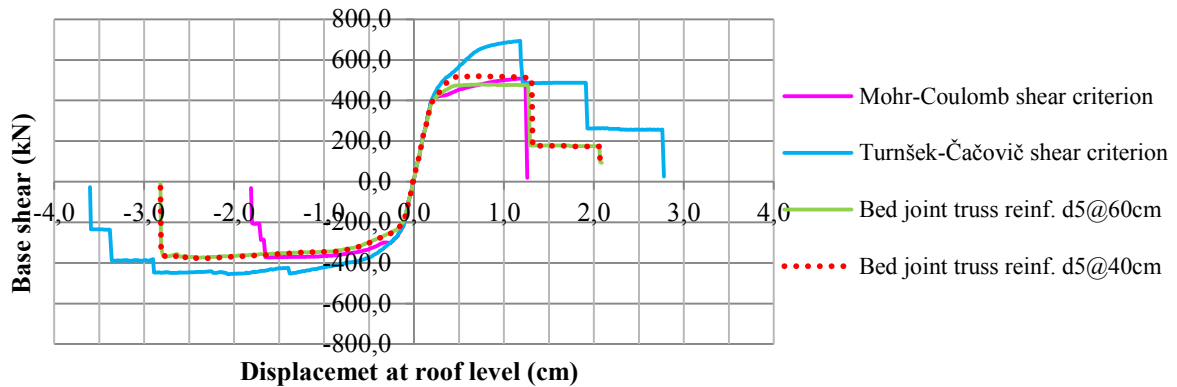

Figure 11: Capacity curves of the isolated dwelling for rightward (+) and leftward (-) loading signs

Effectively, by reinforcing the dwelling with b.j.t.r., improvement in the building response is identified regarding the ductile response according to a first storey mechanism with mainly induced flexural damage. However, only a minor enhancement was achieved by increasing the reinforcement ratio.

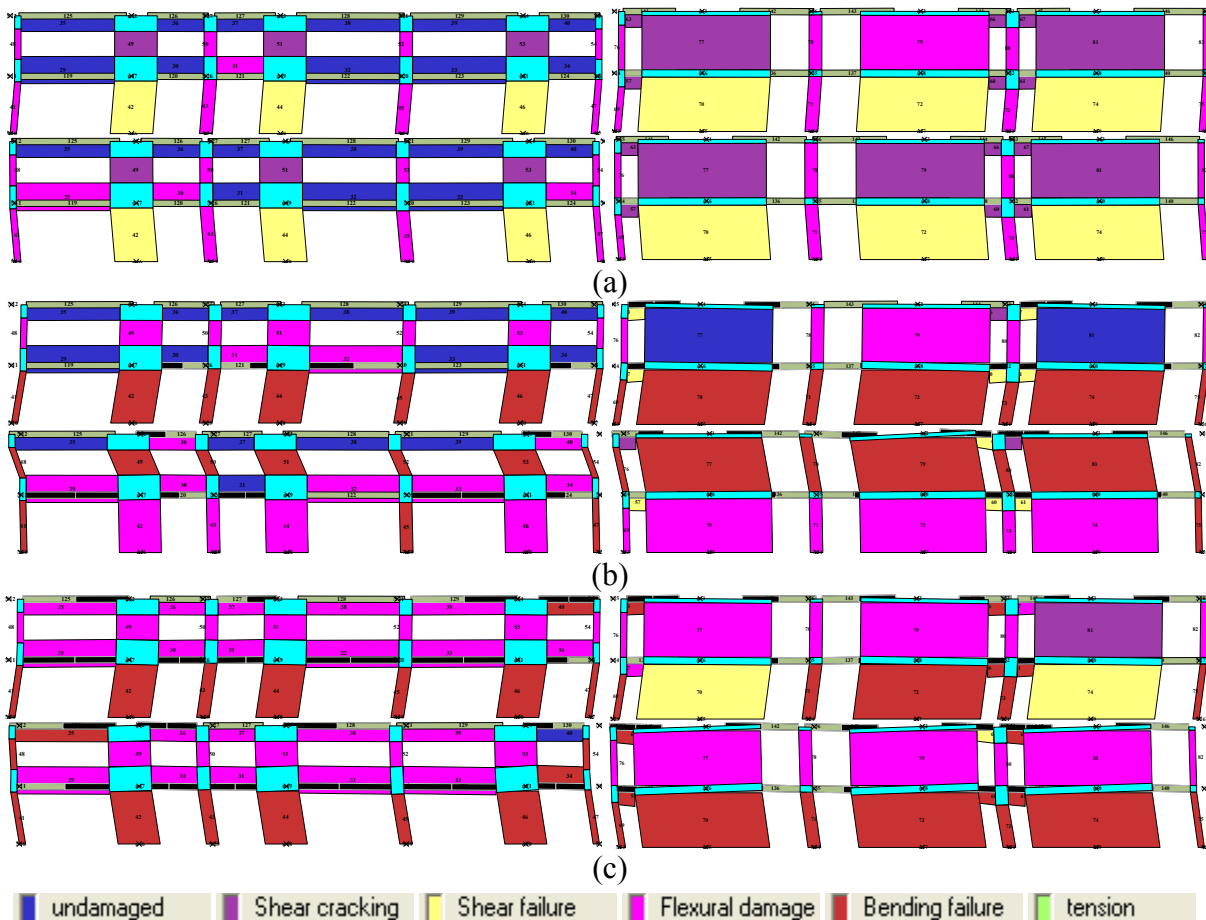

Figure 12: Final damage of the levelled aggregate on the main and central walls for both loading signs considering (a) M-C and (b) T-Č shear criteria, and (c) d5@40cm b.j.t.r.



This means that the addition of reinforcement promotes the development of flexural resisting mechanisms, which is associated to the prevention of the development of typical shear cracking. This appears to be in agreement with the experimental result obtained by Haach et al. (2010) in masonry walls reinforced only at bed joints.

Regarding the levelled conglomeration, the same failure patterns (Figure 12) are in general identified comparing with those of the isolated dwelling. The base shear capacity for rightward loading shown in Figure 13 is proportional (about 3 times) to the isolated building. Storey mechanisms are mainly identified at the first level, which can be related with the fact that internal piers adjacent to transversal walls support two slabs, being then subjected to higher stress values and bending moments.

Comparing with the response of the reinforced isolated dwelling, an improvement of the ductility is also identified on the capacity curve for rightward direction when reinforcing the structure. Even if no apparent structural benefit is obtained by considering the dwellings as a building aggregate, a positive aspect for design is the lower inelastic capacity requested for the structure responding as a building conglomeration in the leftward direction.

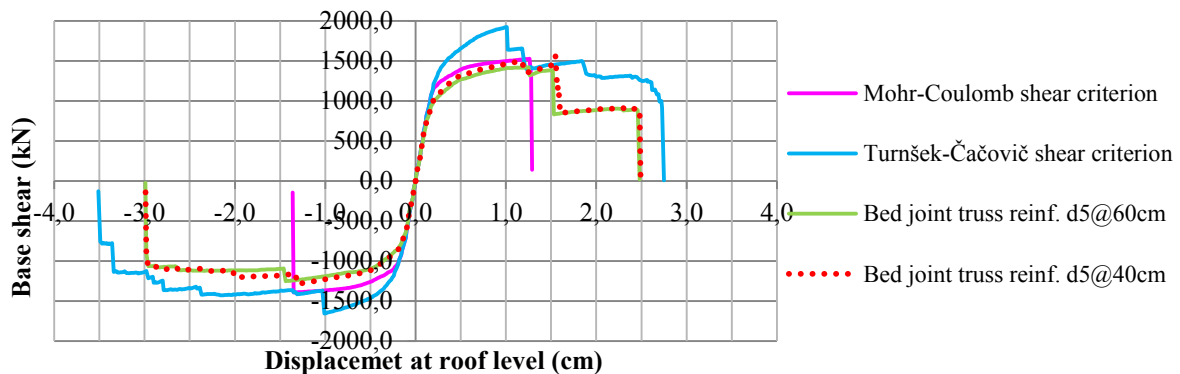

Figure 13: Capacity curves of the levelled aggregate for rightward and leftward loading

Figures 14 and 15 present respectively the capacity curves and the final damage of the unlevelled aggregate. It can be observed that, even if the damage is distributed along the entire building, the aggregate fails in general by the collapse of the pier vertical alignment that makes the connection between the second and third elevated dwellings, which denotes a local failure. This is particularly relevant when shear mode controls the overall response of the masonry building, see Figure 15a, where the failure mechanisms are shown for the M-C shear criterion with rightward loading. This behaviour shows the collapse in second storey of the central dwelling. Concerning the capacity curves, it should be mentioned that no reduction of the base shear is recorded. The main remark is in general the significant loss of displacement capacity (20-40%), which can be perfectly identified on the graph in Figure 16 making a general comparison.

These results appear to confirm that modern construction should take into consideration the structural irregularity of masonry buildings in height by allowing brittle collapse mechanisms under seismic loading.

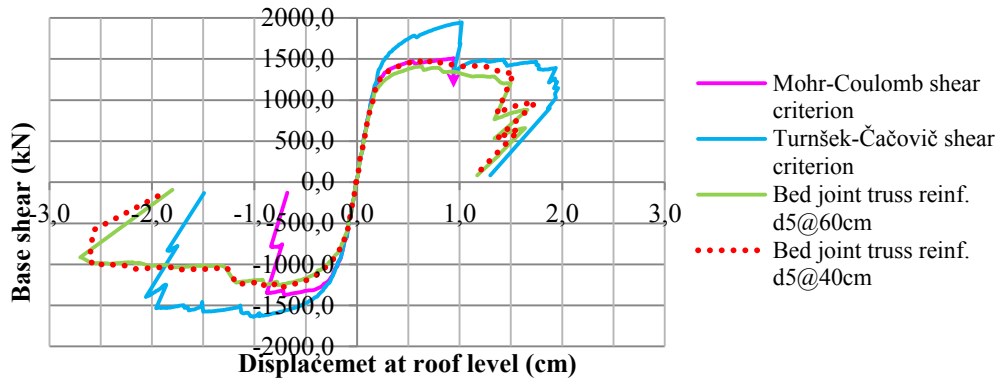

Figure 14: Capacity curves of the unlevelled aggregate for rightward and leftward loads

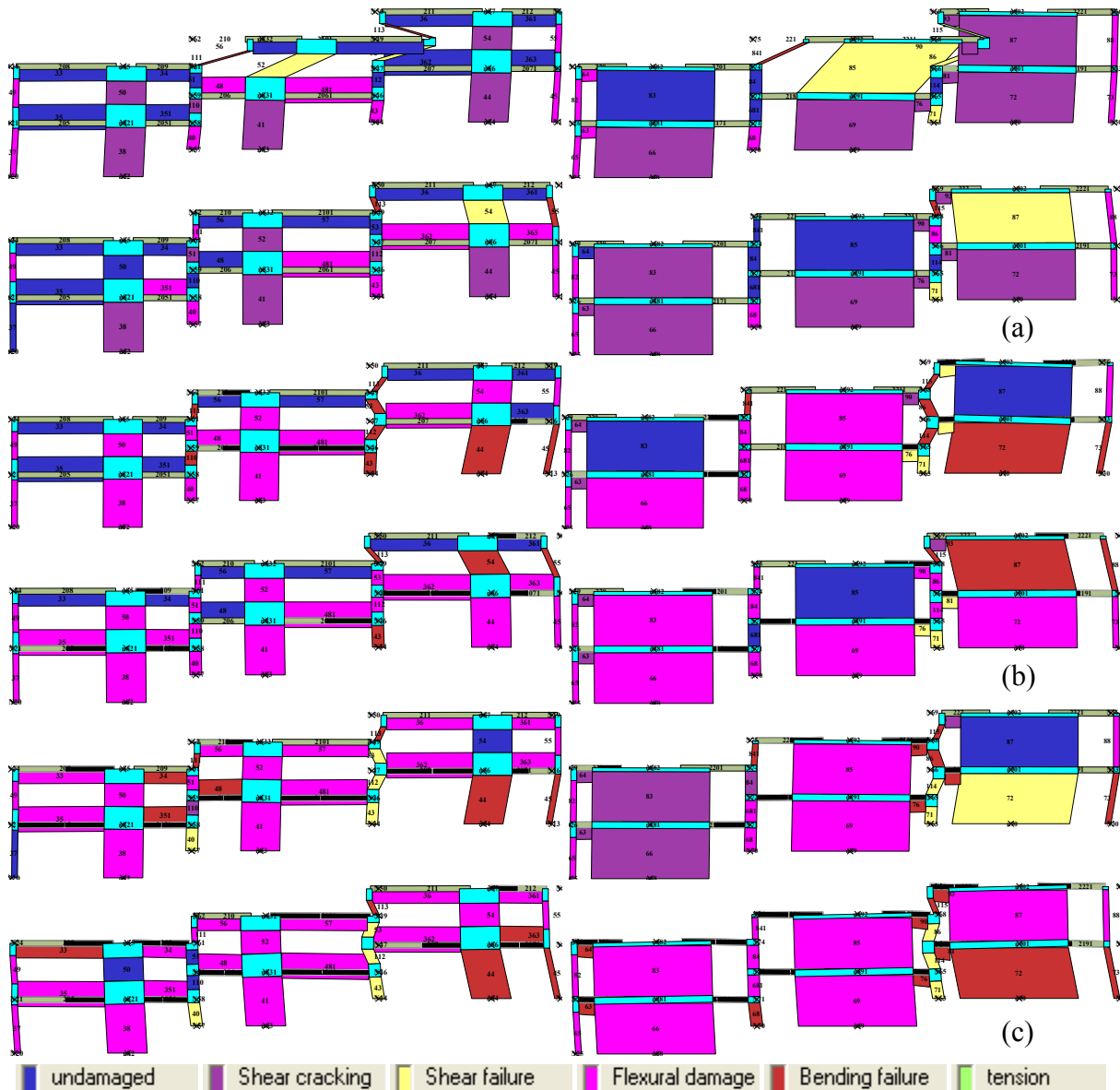

Figure 14: Final damage of the unlevelled aggregate on the main and central walls for both loading signs taking a (a) M-C and (b) T-Č shear criteria, and (c) d5@40cm b.j.t.r.

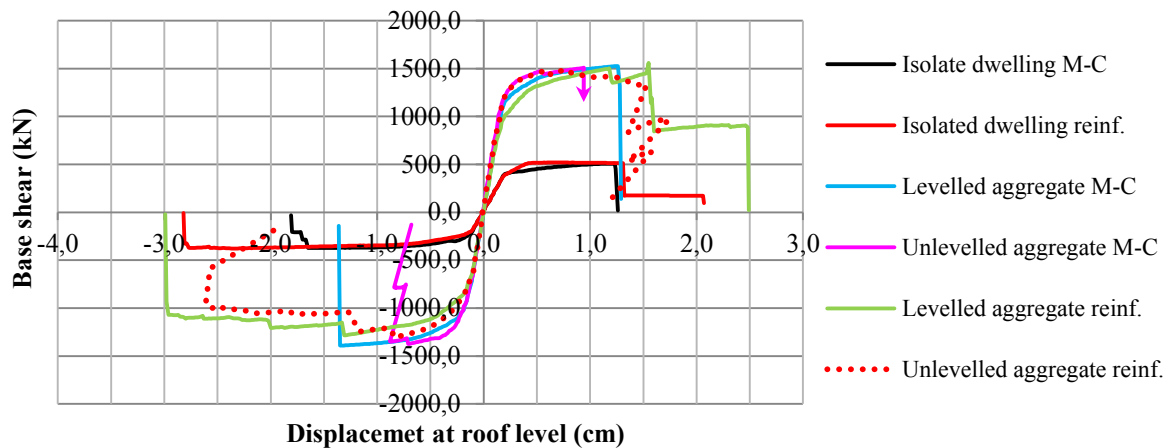

Figure 16: Comparison of capacity curves of the levelled and unlevelled aggregates

CONCLUSIONS

Sustainability of structural masonry at the urban scale requires to understand the behaviour of the masonry buildings in a higher dimension, namely for the case of conglomerated constructions. This paper deals with the seismic response of masonry buildings, trying to capture the changes in the global behaviour when considering a set of dwellings according to conglomerated and unlevelled configurations. Regarding the base shear-displacement response, when a conglomeration of three dwellings is considered, a block effect is slightly observed improving the base shear strength. Note, however, that the displacement capacity observed for the isolated building allows its safety design in the much of Portuguese territory. On the other hand, when considering the dwellings as an unlevelled conglomeration, the introduced structural irregularity in elevation considerably reduces the displacement capacity, due to local damage mechanisms.

Concerning the shear failure mode, a significant better behaviour is observed when considering the Turnšek-Čačovič instead of the Mohr-Coulomb criterion, meaning that the latter criterion is more conservative than the Turnšek-Čačovič. Note that in the Mohr-Coulomb criterion, the shear resisting length of the walls is reduced by the appearance of horizontal flexural cracks associated to low levels of seismic input loading.

By reinforcing the buildings with steel trusses in bed joints, a significant improvement of the ductility is identified, which is however low-sensitive to the reinforcement ratio. Thus, a minimum reinforcement in bed joints with 5 mm diameter longitudinal bars spaced of three courses (0.03% ratio) is recommended.

Finally, regarding the use of performance-based design methodologies, effects of structural irregularity and bed joint reinforcement on the building ductility need to be accounted. The unlevelled conglomeration presents a very complex behaviour, further research being necessary, namely to simulate the masonry zones connecting floors at different levels.

ACKNOWLEDGEMENTS

This work has been funded under the R&D project “ALVEST: Development of Solutions for Structural Masonry”, financed by Portuguese Agency of Innovation through Contract No. 5456. The first author gratefully acknowledges the financial support from the Portuguese Foundation for Science and Technology through the PhD grant SFRH/BD/41221/2007.

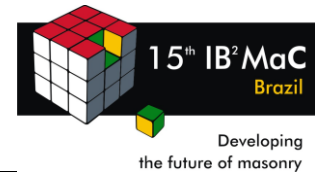

REFERENCES

- Lourenço, P.B., Vasconcelos, G., Gouveia, J.P., Medeiros, P., Marques, R. CBloco: Handbook of Structural Design. Cerâmica Vale da Gândara SA, 2008 (in Portuguese).
- Mosele, F., da Porto, F., Modena, C., di Fusco, A., di Cesare, G., Vasconcelos, G., et al. “Developing innovative systems for reinforced masonry walls”, Proceedings of the 7th International Masonry Conference, London, 2006, CD-ROM.
- Lourenço, P.B., Vasconcelos, G., Medeiros, P., Gouveia, J., Vertically perforated clay brick masonry for loadbearing and non-loadbearing masonry walls, *Construction and Building Materials*, 24 (11), 2010, pp.2317-2330.
- Gambarotta, L., Lagomarsino, S. “On the dynamic response of masonry panels”, Proceedings of the Italian Conference “La meccanica delle murature tra teoria e progetto”, Messina, 1996, pp 451-462 (in Italian).
- Turnšek, V., Čačovič, F. “Some experimental results on the strength of brick masonry walls”, Proceedings of the 2nd International Brick Masonry Conference, Stoke-on-Trent, 1970, pp 149–56.
- Lagomarsino, S., Penna, A., Galasco, A., Cattari, S. “User guide of TreMuri (Seismic Analysis Program for 3D Masonry Buildings)”, University of Genoa, 2009.
- Dolce, M. “Schematization and modelling of masonry buildings subjected to seismic actions”, *L’Industria delle Costruzioni*, 25, 1991, pp 44-57 (in Italian).
- Gouveia, J.P., Lourenço, P.B. “Masonry shear walls subjected to cyclic loading: Influence of confinement and horizontal reinforcement”, Proceedings of 10th North American Masonry Conference, St. Louis, 2007, Paper No. 042.
- Penna, A., Calvi, G.M., Bolognini, D. “Design of masonry structures with bed joint reinforcement”, Proceedings of the Portuguese Seminar “Paredes de Alvenaria: Inovação e Possibilidades Actuais”, University of Minho and LNEC, Lisbon, 2007, pp 21-40.
- Haach, V.G., Vasconcelos, G., Lourenço, P.B. “Experimental analysis of reinforced concrete block masonry walls subjected to in-plane cyclic loads”, *Journal of Structural Engineering*, 136(4), pp.452-462, 2010.