

# Durability of FRP-strengthening masonry bricks under hygrothermal conditions

H. Maljaee

*PhD student, University of Minho, ISE, Department of Civil Engineering, Portugal*

B. Ghiassi

*Postdoc researcher, University of Minho, ISE, Department of Civil Engineering, Portugal*

P. B. Lourenço

*Full professor, University of Minho, ISE, Department of Civil Engineering, Portugal*

D. V. Oliveira

*Associated professor, University of Minho, ISE, Department of Civil Engineering, Portugal*

**ABSTRACT:** Nowadays, there is an increasing interest in using fibre reinforced polymers (FRP) for strengthening masonry elements. It has been observed that these materials, when used for externally bonded reinforcement (EBR), improve the performance of masonry components. However, issues such as durability and long-term performance of strengthened elements are still open. The bond between composite material and masonry substrate is a critical mechanism in EBR strengthening techniques, and therefore its durability and long-term performance should be deeply investigated and characterized. In the present study, the influence of hygrothermal conditions (combined effect of moisture and temperature) on the bond performance is investigated by performing single-lap shear bond tests on two sets of GFRP-strengthened specimens. Different surface preparation techniques are used for each set of specimens to study their effects on the bond degradation. The effect of boundary conditions on FRP delamination is also investigated through visual inspection. The results showed surface grinding significantly improves the bond durability. Extreme FRP delamination was observed in specimens prepared with original brick's surfaces, being mainly due to thermal incompatibility.

## 1 INTRODUCTION

Strengthening masonry structures using Externally Bonded Reinforcement system (EBR) has been recognized as a promising technique. The effectiveness of EBR systems is dependent on the bond behavior between the strengthening material and the substrate (Aiello & Sciolti 2006, Ghiassi et al. 2014, 2015, Oliveira et al. 2011). Environmental conditions can seriously threaten the bond performance, leading to premature debonding or change of expected failure modes. In addition to the short-term performance, understanding the long-term behavior and active degradation mechanisms under different environmental conditions is thus critical for service life predictions (Broughton & Mera 1997).

Although a majority of investigations carried out on the durability of EBR systems are focused on concrete structures (Amidi & Wang 2016, Argoul et al. 2011, Lau & Büyüköztürk 2010, Sen 2015, Silva & Biscaia 2008, Tuakta & Büyüköztürk 2011, Won et al. 2012), the available information on FRP-strengthened masonry elements is still rare (Ghiassi et al. 2013, Ghiassi et al. 2015, Maljaee et al. 2016, Sciolti et al. 2012, 2015). A poor number of studies can be found in the literature performed on the coupled effect of moisture and temperature, which is known as hygrothermal conditions, declaring a need for further investigation in this subject.

Moisture diffusion, as the most deteriorated environmental agent, may cause plasticization and degradation of mechanical properties of epoxy resin and weakening of integrity at interfacial bond level (Karbhari et al. 2003, Maxwell et al. 2005). Exposing epoxy resin to the long-term high temperature, near or above Glass Transition Temperature ( $T_g$ ) may affect irreversibly the mechanical properties (Hollaway 2010). It also increases the rate of moisture absorption and accelerates degradation of mechanical properties (Bao & Yee 2002, Maxwell et al. 2005, Silva & Biscaia 2008). Ghiassi et al. (2015) investigated the effect of 225 cycles of hygrothermal exposure (temperature cycles ranging from +10°C to +50°C and 90% R.H.) on the bond and material properties of GFRP-strengthened extruded solid clay bricks. A significant reduction was reported in the bond strength, epoxy resin and GFRP mechanical properties. Extension of exposure period was demanded since a clear degradation trend was not observed in the recent study. In GFRP-strengthened masonry systems, the thermal incompatibility may cause internal stresses in the bond level between GFRP and masonry substrate. This can result in FRP delamination from the brick surface (Ghiassi et al. 2015). The failure mode also changed from cohesive to adhesive failure due to hygrothermal exposure.

In this paper, the main focus is on the bond degradation between GFRP and clay brick when subjected

to the long-term hygrothermal conditions with temperature cycles ranging from +10°C to +50°C and relative humidity of 90%. The bond degradation was investigated through single-lap shear debonding tests. The FRP delamination was characterized through visual inspection. The effect of mechanical surface treatment on the bond durability was also investigated.

## 2 EXPERIMENTAL PROGRAM

The experimental campaign consisted of exposing FRP-strengthened masonry bricks to hygrothermal conditions in a climatic chamber. The specimens were exposed to 960 hygrothermal cycles lasting for 8 months. The specimens were taken from the climatic chamber at different exposure periods, visually inspected and then mechanically tested.

### 2.1 Materials and specimen preparation

The specimens consisted of extruded solid clay bricks with dimensions of 200×100×50 mm<sup>3</sup> strengthened with Glass Fiber Reinforced Polymer (GFRP) following the wet layup procedure. The GFRP sheets were made of a unidirectional E-glass fiber and a two-part epoxy resin. The bricks were cleaned and then dried in an oven at 100°C for 24 hours. The brick's surfaces were initially prepared using a two-part epoxy primer. After drying of the primer, a layer of epoxy resin was applied on the bricks' surfaces, the glass sheets were then impregnated with epoxy resin and applied on the surface. A slight pressure was finally applied on the GFRP surface with a roller to remove any air voids at the interface.

Two sets of specimens were prepared for single-lap shear bond tests to investigate the effect of surface mechanical preparation on durability of the bond between FRP and masonry substrate. The first set was made of bricks with their original condition (denoted as ORG-specimens). In the second set, however, the bricks' surfaces were grinded for about 5 mm with a mechanical saw before application of the GFRP (denoted as GR-specimens). A total number of 70 specimens was prepared for single-lap shear debonding tests. The GFRP sheets were bonded over a 150×50 mm<sup>2</sup> area, leaving a 40 mm unbonded length at the loaded end. The geometrical details of the specimens are shown in Figure 1.

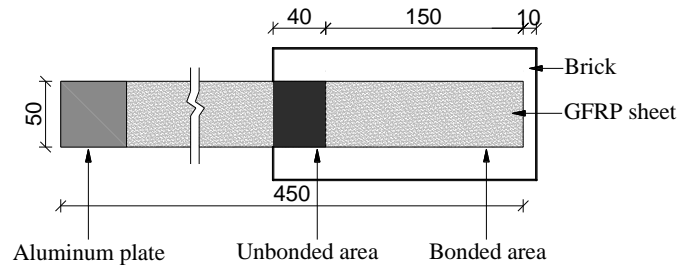

Figure 1. Geometry of the specimens prepared for single-lap shear tests.

Another set of specimens was also prepared for investigating the effect of boundary conditions on FRP delamination. Previous studies have shown that hygrothermal conditions may lead to extensive FRP delamination from the bricks' surfaces in specimens prepared for single-lap shear bond tests (same geometrical details as shown in Figure 1) (Ghiassi et al. 2014, 2015).

To investigate the effect of boundary conditions on FRP delamination, a new set of specimens, denoted as RD- specimens, was prepared provoking restrained delamination conditions by implementation of an unbonded zone in the middle of bonded areas, see Figure 3. This geometry is also representative of real conditions, when FRP is detached from mortar joints or when mortar joints do not exist, and is expected to introduce larger stresses in FRP in unbonded zones. Three groups of specimens with different bonded areas and unbonded lengths were prepared. Group A included samples with 180×70 mm<sup>2</sup> bonded area, having 50 mm unbonded length in the middle. Group B consisted of specimens with 180×40 mm<sup>2</sup> bonded area 50 mm unbonded length and Group C included specimens with 180×70 mm<sup>2</sup> bonded area and 10 mm unbonded length. The specimens were exposed to hygrothermal conditions and were visually inspected for possible delamination after every 60 exposure cycles. One extra set of Group A specimens was prepared and carefully sealed with plastic before exposure to hygrothermal conditions to isolate the effect of moisture. The geometry of the RD-specimens is illustrated in Figure 2.

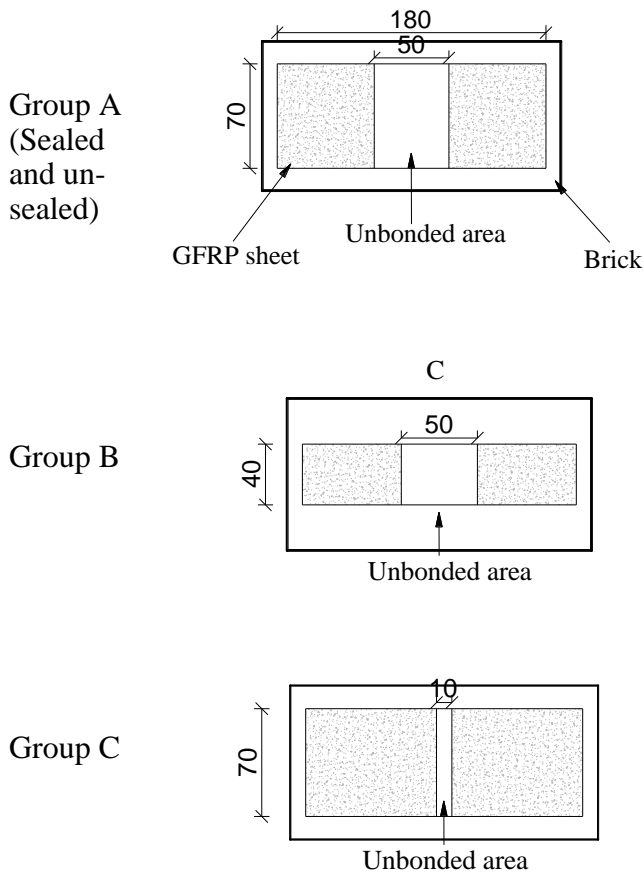

Figure 2. Schematic of specimens for restrained delamination.

The specimens were cured in controlled condition (20°C and 60% RH) for 100 days before tests execution. The properties of constituent materials, obtained from experimental tests, are presented in Table 1, in terms of mean value and coefficient of variation (CoV).

Table 1: Material properties (CoV is given inside brackets)

	Compressive strength (MPa)	Tensile strength (MPa)	Elastic modulus (GPa)
Brick	15.4(8%)	–	–
Epoxy resin	–	58.8(4%)	2.9(8%)
Primer	–	42.0(18%)	2.8(10%)
GFRP	–	1185(8%)	58.8(5%)

## 2.2 Test setup and instrumentation

The test setup for single-lap shear debonding tests included a rigid steel frame and one rigid steel support placing on the top of the specimen. The specimens were clamped to the frame firmly to avoid any misalignment during the load application, see Figure 3. The tensile load was applied at a displacement rate of 0.3 mm/min using a closed-loop servo-controlled testing machine. The relative slip between GFRP sheet and brick was monitored by LVDTs.

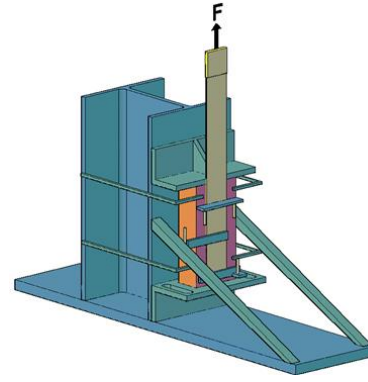

Figure 3. Schematic of test setups for single-lap shear test.

## 2.3 Hygrothermal exposure

Specimens were exposed to hygrothermal conditions in a climatic chamber after 100 days of curing in laboratory conditions. The exposure included 6-hours temperature cycles ranging from +10°C to +50°C with constant relative humidity of 90%, see figure 4. A drop of relative humidity, inside the climatic chamber, to 60% was observed when the temperature reached +10°C, followed by recovering to 90% after a short period. This is a usual situation and happens due to the complexity of controlling the relative humidity at low temperatures.

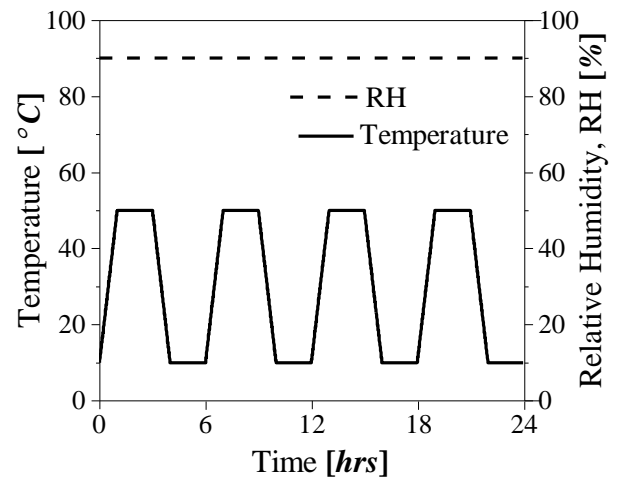

Figure 4. Hygrothermal exposure test condition.

## 3 RESULTS AND DISCUSSION

### 3.1 Visual inspection

All the specimens were visually inspected after every 60 cycles of exposure (15 days). Due to the rel-

ative transparency of the epoxy resin, any possible delamination at the interface level was visible and could be easily detected, as also reported in (Ghiassi et al. 2014, 2015). The observed progressive delamination in RD-specimens is illustrated in Figure 5. In all groups, the delamination started from the unbonded ends, propagated along the sides. The rate of delamination in group C was higher than other groups. This can be due to less FRP bonded width. The sealed specimens showed a similar delamination trend with unsealed ones. Comparing these two groups, it can be observed that the dominant mechanism affected the delamination process was thermal cycles, rather than moisture. The delamination in group B was less than group A during the first 60 cycles. At higher hygro-thermal cycles, no significant difference was observed between group A and B. Indeed, thermal cycles can affect the bond performance between FRP and masonry substrate through the thermal fatigue (Karbhari et al. 2003).

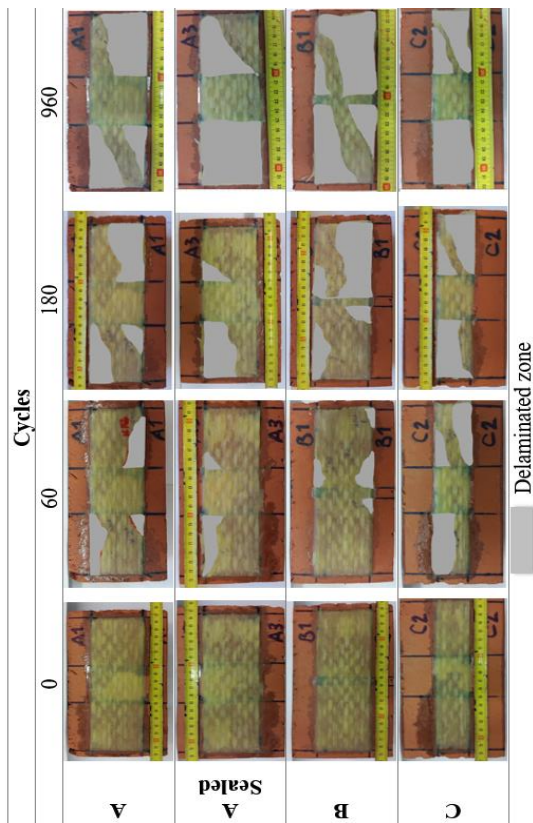

Figure 5. Progressive delamination in RD specimens.

The specimens for single-lap shear tests were also visually inspected before performing the tests. The progression of delamination area in ORG- and GR-specimens is shown in Figure 6. While, the ORG-specimens were progressively delaminated along the tests, no delamination was observed in GR-specimens.

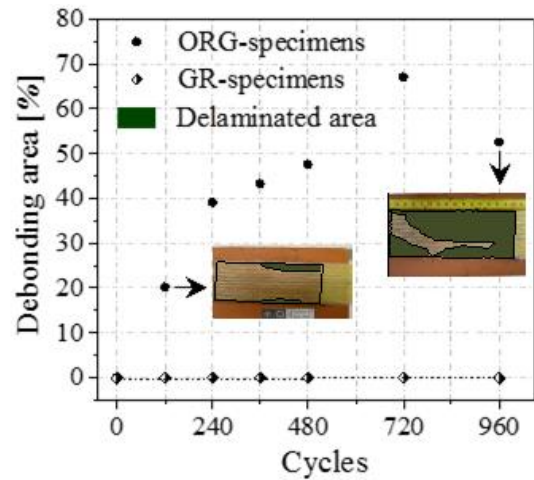

Figure 6. Variation of debonding area in ORG- and GR-specimens.

### 3.2 Shear debonding tests

The changes in debonding force in ORG- and GR-specimens are shown in Figure 7. A significant reduction of debonding force was observed in ORG-specimens during the first 120 cycles (about 50%). The degradation in ORG-specimens continued with a lower rate reaching 72% at the end of the exposure. Despite no degradation in the bond performance in GR-specimens, a slight increase was observed in their debonding force. This increment can be due to curing time, post-curing of epoxy resin at the interface level or variability of the specimens. The results show the significant effect of surface treatment on improving the bond performance and durability. The typical failure mode of ORG-specimens before exposure was adhesive failure mode with detachment of a thin layer of a brick. After exposure to hygrothermal conditions, the failure mode changed to adhesive failure mode with detachment at FRP-brick interface. The observed failure mode in unconditioned GR-specimens was cohesive failure mode with the fracture inside the brick substrate and remained the same after the exposure, see Figure 8.

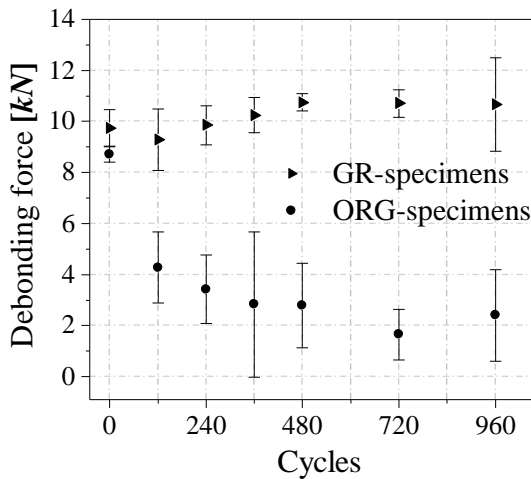

Figure 7. Variation of debonding force in ORG and GR specimens.

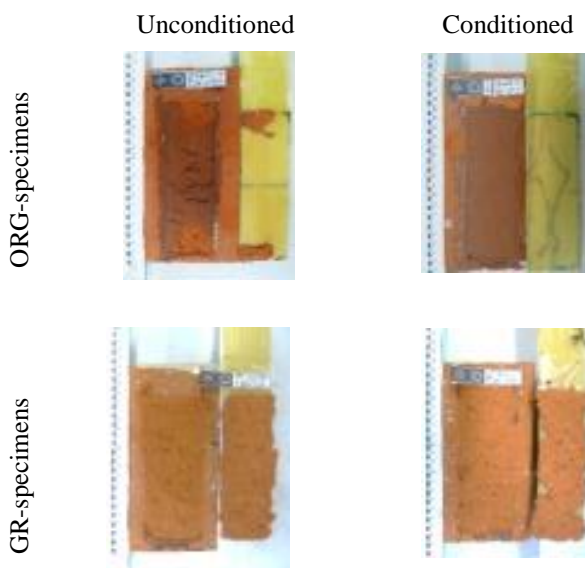

Figure 8. Failure modes before and after exposure.

#### 4 CONCLUSION

The effect of hygrothermal conditions on durability of FRP-strengthened brick masonry was investigated in this study by performing accelerated aging tests. The tests included exposing the specimens to temperature cycles (between +10°C and +50°C) and constant relative humidity (90%) in a climatic chamber. The main focus was on the changes of bond performance at FRP-brick interface. In the specimens prepared for restrained delamination tests, the effect of unbonded length on the delamination process was insignificant at higher temperature cycles. The rate of delamination increased with decreasing bonded length. Sealed specimens showed no improvements in bond performance in comparison with the unsealed specimens. The bond characterization tests showed that grinding

the bricks' surfaces before application of GFRP significantly improves the bond durability. While specimens with mechanical surface treatment (GR-specimens) showed no degradation in the bond performance, extensive FRP delamination and degradation in bond strength were observed in specimens prepared without any surface treatment.

The results showed that FRP delamination occurs due to thermal incompatibility between FRP and masonry substrate. Moreover, FRP delamination in restrained conditions, being the case of real conditions when weak mortar joints exist, was extremely large.

#### 5 REFERENCES

- Aiello, M. A., & Sciolti, S. M. 2006. Bond Analysis of Masonry Structures Strengthened with CFRP Sheets. *Construction and Building Materials* 20(1-2): 90–100.
- Amidi, S. & Wang, J. 2016. Subcritical Debonding of FRP-to-Concrete Bonded Interface under Synergistic Effect of Load, Moisture, and Temperature. *Mechanics of Materials* 92: 80–93.
- Argoul, P., Benzarti, K., Freddi, F., Frémond, M. & Nguyen, T. H. T. 2011. A Damage Model to Predict the Durability of Bonded Assemblies - Part II: Parameter Identification and Preliminary Results for Accelerated Ageing Tests. *Construction and Building Materials* 25(2): 556–67.
- Bao, L. R. & Yee, A. F. 2002. Effect of Temperature on Moisture Absorption in a Bismaleimide Resin and Its Carbon Fiber Composites. *Polymer* 43(14): 3987–97.
- Broughton, W. R., & Mera, R. D. 1997. *Review of Life Prediction Methodology and Adhesive Joint Design and Analysis Software*. Teddington, UK.
- Ghiassi, B., Marcari, G., Oliveira, D. V. & Lourenço, P. B. 2013. Water Degrading Effects on the Bond Behavior in FRP-Strengthened Masonry. *Composites Part B: Engineering* 54: 11–19.
- Ghiassi, B., Xavier, J., Oliveira, D. V. Kwiecien, A. Lourenço, P. B. Zajac, B. 2015. Evaluation of the Bond Performance in FRP-brick Components Re-Bonded after Initial Delamination. *Composite Structures* 123: 271–81.
- Ghiassi, B., Lourenço, P. B. & Oliveira, D.V. 2015. Accelerated Hygrothermal Aging of Bond in FRP-masonry Systems. *Journal of Composites for Construction* 19(3): 04014051.
- Ghiassi, B., Oliveira, D. V. & Lourenço, P. B. 2014. Hygrothermal Durability of Bond in FRP-Strengthened Masonry. *Materials and Structures* 47(12): 2039–50.
- Ghiassi, B., Verstryngge, E., Lourenço, P. B. & Oliveira, D. V. 2014. Characterization of Debonding in FRP-Strengthened Masonry Using the Acoustic Emission Technique. *Engineering Structures* 66: 24–34.

- Hollaway, L. C. 2010. A Review of the Present and Future Utilisation of FRP Composites in the Civil Infrastructure with Reference to Their Important in-Service Properties. *Construction and Building Materials* 24(12): 2419–45.
- Karbhari, V. M., Chin, J. W., Hunston, D., Benmokrane, B., Juska, T., Morgan, R., Lesko, J. J., Sorathia, U., Reynaud, D. 2003. Durability Gap Analysis for Fiber-Reinforced Polymer Composites in Civil Infrastructure. *Journal of Composites for Construction* 7(3): 238–47.
- Lau, D., & Büyüköztürk, O. 2010. Fracture Characterization of Concrete/epoxy Interface Affected by Moisture. *Mechanics of Materials* 42(12): 1031–42.
- Maljaee, H., Ghiassi, B., Oliveira, D. V. & Lourenco, P. B. 2016. Moisture-induced degradation of interfacial bond in FRP-strengthened masonry. *Composites Part B: Engineering* 87:47–58.
- Maxwell, A. S., Broughton, W. R., Dean, G. & Sims, G. D. 2005. NPL Report DEPC MPR 016 *Review of Accelerated Ageing Methods and Lifetime Prediction Techniques for Polymeric Materials*. Teddington, UK.
- Oliveira, D. V., Basilio, I. & Lourenço, P. B. 2011. Experimental Bond Behavior of FRP Sheets Glued on Brick Masonry. *Journal of Composites for Construction* 15(1): 32–41.
- Sciolti, M. S., Aiello, M. A. & Frigione, M. 2012. Influence of Water on Bond Behavior between CFRP Sheet and Natural Calcareous Stones. *Composites Part B: Engineering* 43(8): 3239–50.
- Sciolti, M. S., Aiello, M. A. & Frigione, M. 2015. Effect of Thermo-Hygrometric Exposure on Frp, Natural Stone and Their Adhesive Interface. *Composites Part B: Engineering* 80: 162–76.
- Sen, R. 2015. Developments in the Durability of FRP-Concrete Bond. *Construction and Building Materials* 78: 112–25.
- Silva, M. A. G., & Biscaia, H. 2008. Degradation of Bond between FRP and RC Beams. *Composite Structures* 85(2): 164–74.
- Tuakta, C., & Büyüköztürk, O. 2011. Deterioration of FRP/concrete Bond System under Variable Moisture Conditions Quantified by Fracture Mechanics. *Composites Part B: Engineering* 42(2): 145–54.
- Won, J.P., Yoon, Y. N., Hong, B. T., Choi, T. J. & Lee, S. J. 2012. Durability Characteristics of Nano-GFRP Composite Reinforcing Bars for Concrete Structures in Moist and Alkaline Environments. *Composite Structures* 94(3): 1236–42.