

COMPARATIVE SIMULATION STUDY OF PRODUCTION SCHEDULING IN THE HYBRID AND THE PARALLEL FLOW

Maria L.R. Varela¹, Justyna Trojanowska², Silvio Carmo-Silva³, Natalia M.L. Costa⁴, Jose Machado⁴

^{1,3,4} *University of Minho, Department of Production and Systems*

² *Poznan University of Technology, Chair of Management and Production Engineering*

⁵ *University of Minho, Department of Mechanical Engineering*

Corresponding author:

University of Minho

Department of Production and Systems

Azurém Campus, 4804 – 533, Guimarães, Portugal

e-mail: leonilde@dps.uminho.pt

ABSTRACT

Scheduling is one of the most important decisions in production control. An approach is proposed for supporting users to solve scheduling problems, by choosing the combination of physical manufacturing system configuration and the material handling system settings. The approach considers two alternative manufacturing scheduling configurations in a two stage product oriented manufacturing system, exploring the hybrid flow shop (HFS) and the parallel flow shop (PFS) environments. For illustrating the application of the proposed approach an industrial case from the automotive components industry is studied. The main aim of this research to compare results of study of production scheduling in the hybrid and the parallel flow, taking into account the makespan minimization criterion. Thus the HFS and the PFS performance is compared and analyzed, mainly in terms of the makespan, as the transportation times vary. The study shows that the performance HFS is clearly better when the work stations' processing times are unbalanced, either in nature or as a consequence of the addition of transport times just to one of the work station processing time but loses advantage, becoming worse than the performance of the PFS configuration when the work stations' processing times are balanced, either in nature or as a consequence of the addition of transport times added on the work stations' processing times. This means that physical layout configurations along with the way transport time are including the work stations' processing times should be carefully taken into consideration due to its influence on the performance reached by both HFS and PFS configurations.

KEYWORDS

approach for supporting manufacturing scheduling decision making, heuristics, hybrid flow shop, parallel flow shops, makespan

Introduction

Scheduling production, which is assign to resources that complete the work, is a very important issue from a practical point of view. Proper scheduling requires complex information of tasks. Due to the diversity of scheduling problems, problem definition and characterization can benefit from a

scheduling problem specification nomenclature or ontology [1].

We may address scheduling problems by recognizing two main classes of manufacturing environments, namely Product Oriented Manufacturing Systems (POMS) and Function Oriented Manufacturing Systems (FOMS) [2]. Product Oriented Manufacturing Systems are manufacturing systems designed for the manufacture of a single type of product or a family of similar

products. Function Oriented Manufacturing Systems are manufacturing systems, capable of manufacturing the whole or a large spectrum of products of a company, characterized by the existence of functional work centres or departments, each one capable of carrying out a single type of process or manufacturing function. Families of products manufactured in POMS do not always match with market demand families. They are groups of different items that can and should be manufactured together, because they can share the same dedicated set of production resources and processes and, frequently, the same manufacturing operations' sequence. In this case, the manufacturing system may be configured as a flow shop. POMS advantage, in contrast to FOMS, is better product delivery times, productivity and product quality, what follows from the fact that POMS its high system dedication to the manufacturing of products.

As a result of capacity requirements, in real manufacturing systems more than a single processor or machine per processing stage are requested. Hence, flow shop like POMS may have at each stage a set of replicated or parallel machines, i.e. equivalent machines, which frequently can be considered identical. By replicating machines at different processing stages it is possible to increase throughput, to balance production capacity across the shop floor and, therefore, eliminate or reduce negative effects of bottlenecks on the overall shop efficiency.

In this paper an approach is proposed for supporting scheduling decision making regarding problems that may occur in two different manufacturing environments, which are the Hybrid Flow Shop (HFS) and the Parallel Flow Shop (PFS). Moreover, different kind of transportation mechanisms can also be considered, which will affect the corresponding transportation time and, consequently, turn one type of manufacturing environment to be better suited for a given manufacturing scenario than the other one. Moreover, this paper analyses an industrial case study of the automotive industry as reported by Costa and Varela [3]. Manufacturing system, described in this paper, to consist of thermoforming and pressing operations on a set of car parts, which may either be considered in the context of different manufacturing environments.

The case is studied as two different manufacturing system configurations which may be considered extensions of the classical flow shop system [4, 5]. Thus, two production scheduling problems were identified, according to the

underlying manufacturing system's configurations: a PFS problem, which consists on a replication of two or more simple flow shops in parallel [6] and a HFS problem, which includes two or more machines on one or more of its stages [7-9].

The paper is organized as follows: section 2 presents a short overview of manufacturing systems and scheduling methods. Section 3 briefly reviews the literature on hybrid and parallel flow shops. Section 4 describes the proposed manufacturing scheduling decision support approach. Section 5 analyses the industrial case study carried out. Section 6 presents and discusses results obtained. Section 7 shows an extended study for further comparing the performance of the HFS and the PFS problems, considering transportation time requirements. Finally, section 8 summarizes the main conclusions and proposes future work.

Manufacturing scheduling

A. Manufacturing systems

In a HFS there are two or more identical or equivalent machines or processors in one or more of the processing stages [4, 5]. If a single processor or machine exists per stage, in a flow shop with two stages, the problem of finding an ordered scheduled of a number of tasks, for minimizing makespan, is solvable to optimality in polynomial time [4]. If the number of machines is larger than two, then the problem becomes increasingly more complex and strongly NP-hard [5, 10]. It is known that most real world flow shop problems are NP-hard [6].

The HFS differs from a classical flow shop in that at least one stage has two or more identical machines, while in the classical one only one machine exists per stage. The jobs' flow in both cases is direct or in sequence [7, 8, 11-18]. Thus, all jobs have multiple operations and are processed without preemption, following the same linear path through the system. Some authors refer the HFS as a flexible flow shop or flexible flow line [17].

The PFS environment may be defined as a replication of several classical flow shops, i.e., instead of having just one classical flow shop we may have several of them, in parallel, and all of them integrating an unique manufacturing system [6].

The scheduling problem in a HFS environment may also be seen as a generalization of the parallel-machine shop scheduling problem with a single stage, which has been proved to be a NP-hard scheduling problem [18].

A HFS is a manufacturing system that offers much flexibility but puts high demand on jobs handling [16-18].

Alternative manufacturing systems with a quite simple production flow include several variants of flow shop based systems, varying from simple flow shops, up to no-wait flow shops or lines and parallel flow shops [19-21].

The manufacturing system considered by Vairaktarakis and Elhafsi [21] consists of a parallel flow line design, studied for the two stage case, with F_1, \dots, F_m , flow shops, each consisting of a series of two machines M_{1i} and M_{2i} ($i = 1, \dots, m$). Vairaktarakis and Elhafsi were also address the Parallel Hybrid Flow Line problem with two stages where m parallel hybrid flow lines are defined with an identical machine in the stage one for each line and the sharing of the whole set of identical m machines in the second stage.

B. Scheduling methods

In the literature we can find a wide variety of scheduling methods, varying from discrete programming [22] to meta-heuristics [23] and artificial intelligence based methods [24-28].

Unfortunately, practical implementations were made only for certain constraints, for example for one or two machines, for cyclic production [29-31], and additional assumptions (e.g. infinite storage capacity) meant that these solutions are in most cases difficult to be directly and appropriately used in industrial practice.

Frequently occurring disturbances cause the need to update the schedule and adapt it to current production conditions. Production scheduling in terms of dynamically changing factors influencing the manufacturing system predictive-reactive scheduling are applicable [32-37]. Many strategies for production planning and control under disturbances have been presented in the literature dedicated to flexible manufacturing cells and systems [38-42]. The literature also indicates the availability of such strategies for other manufacturing systems, such as: the single machine systems [43-45], the parallel machine systems [46, 47], the flow shops [48] and the job shops [49,50].

For NP-hard scheduling problems heuristics are the major way to solve these problems in acceptable time. En example of simple heuristics are dispatching rules. Heuristic methods are methods that have been largely applied to solve scheduling problems. This is because frequently they are intuitive and easy to implement [51-57].

Important generic procedures referred to as meta-heuristics, many involving biologically inspired computing and other natural phenomena, have been used to develop highly effective and efficient heuristics for complex scheduling problems [51-75].

Many authors [23-29] have contributed with several methods, i.e., algorithms and heuristics for solving problems in the manufacturing environment addressed in this paper and other environments.

Described methods are available through integrated scheduling systems, for example LEKIN [23], which is available free of charge, Lisa [24], and among many others described in [58-75].

For solving the HFS, described in this paper, we were used LEKIN scheduling system, which includes several kinds of methods for a variety of manufacturing environments, such as, single machine, parallel machines, flow shop, job shop, flexible or hybrid flow shop, and flexible job shop environments. This system uses dispatching rules, built-in heuristics and user-defined heuristics to solve problems to meet several criteria, including, C_{max} , maximum tardiness, total number of late jobs, total flow time, total tardiness, total weighted flow time and total weighted tardiness [51].

The aim of this research to achieve satisfied result for the makespan minimization criterion in automotive industrial case modelled as hybrid flow shop and the parallel flow shop.

State of art

In this section a brief literature review of HFS and PFS manufacturing environments is presented for a better contextualization of the study described in this paper.

A. Hybrid flow shop

The HFS scheduling attracted many researchers after Johnson's seminal paper [4].

The first research papers about HFS scheduling did appear in the 1970's with Salvador [9]. Few years later, Garey and Johnson [10] did show that the HFS problem with makespan objective is NP-complete. Due to this, a large number of heuristics and approximation algorithms have been proposed for different HFS configurations. During the last decade, the research has focused on problems as sequence-dependent setups on machines, machine eligibility, time lags on operations, precedence constraints among jobs, etc. in order to bridge the gap between theory and practice [11]. For machines

without setup times, the proposed dispatching rules are a class of least slack policies that prioritize each job by the difference between its due date or some surrogated measure of it, and the expected amount of time until the job is completed. For resources with setup times, the proposed dispatching rules focus on completing all waiting jobs of one type before performing a setup and processing jobs of another type [76].

Studies on HFS scheduling problems are relatively more recent. Main results deal with makespan criterion and are often limited to two stages. Nevertheless, some work has been done on lateness and tardiness criteria, and important reviews on HFS scheduling date from 1999 [12, 13].

Among recent publications, Ruiz and Maroto [14] made a comparison of 25 methods, ranging from the classical Johnson's algorithm and dispatching rules to the most recent meta-heuristics. It was also described advanced algorithms considering makespan minimization on hybrid flexible flow shops problems [15]. Another study carried out by Nowicki and Smutnicki [16] presented a fast and easily implementable approximation algorithm for the problem of finding a minimum makespan in a HFS. Moreover, Ribas, et al. [11] made an overview about the state of the art on HFS scheduling problems and Quadt and Kuhn put forward a taxonomy of HFS scheduling procedures [17].

B. Parallel flow shop

Makespan minimization is one of the most frequently studied criteria in the scheduling literature. Cheng, et al. [18] put forward a shifting bottleneck approach for a parallel flow shop (PFS) scheduling problem. Also other authors developed an approximation algorithm for two and three stage PFS to minimize makespan [19]. Furthermore, Cao and Chen [20] used tabu search algorithm to study parallel flow shop scheduling and developed a mathematical programming model for combined part assignment and job scheduling.

Other relevant studies on the PFS problem have been carried out by [6]. It was for example a multi-simulation study to examine the effectiveness of a heuristic algorithm for small and large problems to minimize makespan in proportional PFS. Vairaktarakis and Elhafsi, also proposed the use of flow lines to simplify routing complexity in two-stage flow shops [21].

Proposed approach

The approach proposed supports the choice of the combination setting of manufacturing system configuration and material handling or transportation equipment or means, as they can influence transport times between work stations and, therefore, manufacturing system's performance. The manufacturing system configurations considered are, the HFS and PFS with two manufacturing stages.

The approach steps are illustrated in Figure 1.

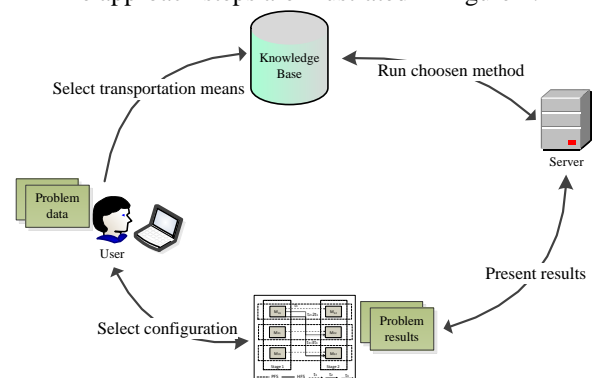

Fig. 1. Proposed approach to support the selection of appropriate scheduling methods for a specified manufacturing system's configuration and transportation means

It starts with the insertion of the data of the manufacturing scheduling problem instance, for configurations HFS or PFS, by the user, through the Scheduling Decision Support System (SDSS) interface. After, additional information about the transportation means to be considered in the scheduling problem is defined. This information takes the form of transport times between workstations. Next a search process is carried out on the SDSS's Knowledge Base (KB) about appropriate methods for solving the considered scheduling problem. A selected method is run on a server and the results obtained presented to the user. This allows the user to judge about the quality of the solutions and compare them for each system configuration combined with additional features related to the transportation requirements between workstations in the considered scheduling problem to be solved.

The conceptual arrangement of the manufacturing system configuration, which can be run either as a HFP or PFS, is shown in Figure 2. These alternative configurations are based on a physical setting that is unchanged. So, it is the management logic that configures the system as either an HFS or a PFS. To be more specific it is the

routing of the jobs' operation to the second stage of manufacturing, provided with a set of identical machines that configures the system as either a PFS or a HFS configuration.

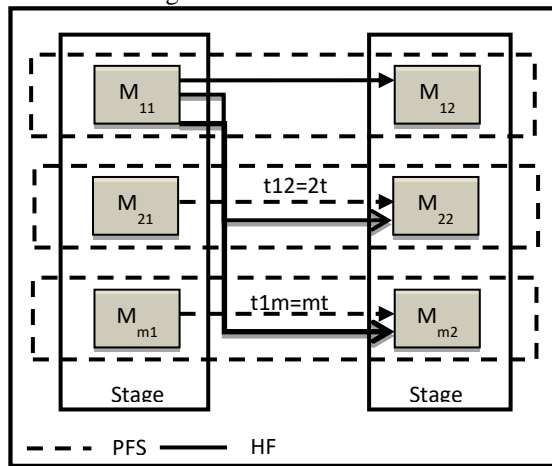

Fig. 2. General configuration

Assumptions regarding the alternative manufacturing system configurations and the underlying production flow and transportation means and corresponding times are as follows:

- The conceptual physical arrangement considered is the one illustrated in the Figure 2. This is a fundamental assumption to the case dealt with in this paper.
- The minimum transportation time occurs between adjacent machines in the parallel flow-shop system (PFS) configuration, which is t and denoted by t_{ij} for all $i=j$ with i and $j = 1, \dots, m$, as illustrated in Figure 2.
- Transport time to other stations are proportional to t and dependent on the distance measure by the absolute value of the difference between the number of the station that processes the 1st operation and the one that processes 2nd operation, plus one, i.e.:

$$t_{ij} = t(|i - j| + 1)$$

where i stands for the index of the machine for the 1st operation and j for the 2nd one.

- The transportation times can vary according to the type of transportation means used. Transport may be manual or can be performed by some devices or vehicles, e.g. automated guided vehicles.

We decided to assume that distances between adjacent machines are identical. This allows specifying transport times as a function of the relative layout position of the machines that are

visited next. Thus, we can test the two manufacturing systems configurations on the basis of identical relative positions of the machines used for processing jobs and therefore be on equal comparative basis as far transport times between stations are concerned.

This is, in the opinion of the authors, a way of being able to compare the two configurations, i.e. PFS and HFS, without introducing complexity that could make it difficult to evaluate performance behavior of the configurations when transport times between stations change due to either the use of different handling devices or distance between workstations, or both.

This gives some degree of generality to results that could not be obtained if we consider different distances between workstations. In this case results could be due to these differences and not to the management logic, i.e. based on PFS or HFS as intended.

Problem description

The automotive industrial case scheduling problem described in this paper affects with a two-stage manufacturing process [3], which consist of a thermoforming (requires heating a mould) and a pressing operation (consists of a press cutting operation) is shown in Table 1. These operations are applied to twelve types of jobs. Three mould heaters and three presses are available to execute these jobs. Each job requires a heating operation and a pressing operation. It is important that jobs must be processed by a heater before they can be further processed by a press. The 12 jobs' processing times is shown in Table 1. The jobs must be executed without pre-emption.

Two POMS are configured: one as a PFS and the other as a HFS as shown in Figures 3 and 4. Moreover, additional information about transportation requirements, including times and routings, is specified for each configuration. The resulting scheduling problems are solved using some heuristics and meta-heuristics.

In the conducted research were handled various approaches, rest on hybrid flow shop and parallel flow shop manufacturing configurations, for scheduling the two operations of the twelve tasks, along with the specification of transportation means between workstations of stage 1 and stage 2, according to the proposed approach described in section IV.

Table 1. Processing times

Task	Heating time (seconds)	Press time (seconds)	Total time (seconds)
1	320	600	920
2	320	210	530
3	320	400	720
4	230	200	430
5	280	267	547
6	320	167	487
7	230	267	497
8	280	147	427
9	280	150	430
10	300	200	500
11	230	300	530
12	230	147	377

In a previous study [77], referred here as Case 1, which did not consider transportation times, it was shown that the HFS had a clearly better performance than the PFS on the makespan measure.

Here we make an extension of the study by considering transport times between workstations and using the best performing scheduling algorithm from the previous study, namely the shifting bottleneck routine (SBR) available in the LEKIN scheduling system. This was the algorithm with the best results for both scenarios, HFS and PFS.

The PFS problem

The PFS problem involves three two stage parallel flow shops, as illustrated in Figure 3.

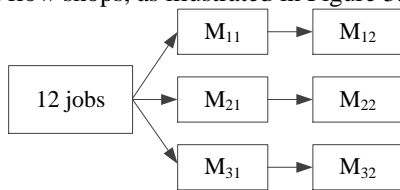

Fig. 3. The PFS configuration

For solving the PFS scheduling problem in the Case 1, three different scheduling methods were considered: a kind of total enumeration procedure, the Kedia heuristic combined with the Johnson’s rule and the General Shifting Bottleneck Routine (SBR) available in LEKIN scheduling system [77].

The HFS Problem

In this section hybrid flow shop was considered. In Fig.4 shown a two-stage hybrid flow shop. In this configuration a set of jobs has to be processed on a

set of processing centers. Each machine centre consists of a set of identical parallel machines, and the non-pre-emptive processing of a job has to be done on exactly one of the machines of each centre. The LEKIN system was used for applying following dispatching rules:

- first come first served (FCFS),
 - longest processing time (LPT),
 - shortest processing time (SPT),
- and a built-in heuristic, which was the shifting bottleneck for the HFS [77].

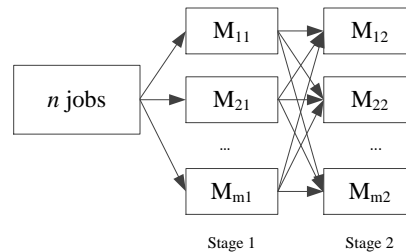

Fig. 4. A two-stage hybrid flow shop

Overall results and discussion

Considering the results obtained for both configurations, namely PFS and HFS, the best average C_{max} per job, namely 1317 min, shown in figure 5, was achieved for the HFS, through the application of the General Shifting Bottleneck heuristic.

These results are awaited given the fact that hybrid flow shop is more flexible than the parallel flow shop, enabling you to achieve higher resource utilization. However, the degree of utilization of resources positively affects the value of makespan.

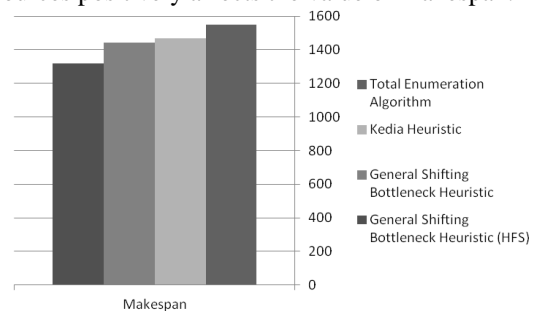

Fig. 5. Comparison of different makespan results for PFS and HFS configurations by using different scheduling approaches

Case Study Extension

Now, we extend the analysis for evaluating the impact of changing conditions related to

transportation times, for the two configurations studied, namely PFS and HFS, using the best performing scheduling method referred, which was the General Shifting Bottleneck heuristic.

Thirty problem instances, including 12 jobs (as in the original industrial case - Case 1) were considered.

Therefore, we did repeat the execution of the General Shifting Bottleneck method, available through the Lekin scheduling system, first for two additional situations (Case 2.1 and 2.2), as described below:

Case 2.1: 30 problem instances with balanced work load between both processing stages (operations) for the 12 jobs considered and a scenario 1, with 1 minute of transport time, included just in the processing time of the first operation/ stage.

Case 2.2: 30 problem instances with balanced work load between both processing stages (operations) for the 12 jobs considered and a scenario 2, with 2 minutes of transport time, but distributed similarly through both operations/ stages.

Regarding each of the two scenarios of transport times: scenario 1, with 1 minute, and scenario 2 with 2 minutes of transport time, between adjacent workstations, considered in the Cases 2.1 and 2.2, we must refer that we converted the tasks' processing times of seconds in minutes to use coherent measures of time.

Using the best algorithm already referred, we calculated the makespan for all the 30 problems instances regarding the Cases (2.1, 2.2). For all problem instances evaluated this differences did vary between 0 and 3 minutes. If differences are zero each configuration counts one in the 0 distance to the best. If it is one it counts one for the best (the other accounts for zero in the total counting), as shown in Figures 6 and 7.

T-Test between averages was considered for performing the statistical analysis considering both configurations PFS and HFS. Tables II and III show the results obtained considering the two hypotheses, corresponding the two referred scenarios.

$$H_0: \mu_{HFS} = \mu_{PFS}$$

$$H_1: \mu_{HFS} \neq \mu_{PFS}$$

For both scenarios it is not possible to assume equal means, as the null hypothesis H_0 , was rejected with 95% of confidence level ($p\text{-value} = X < \alpha$).

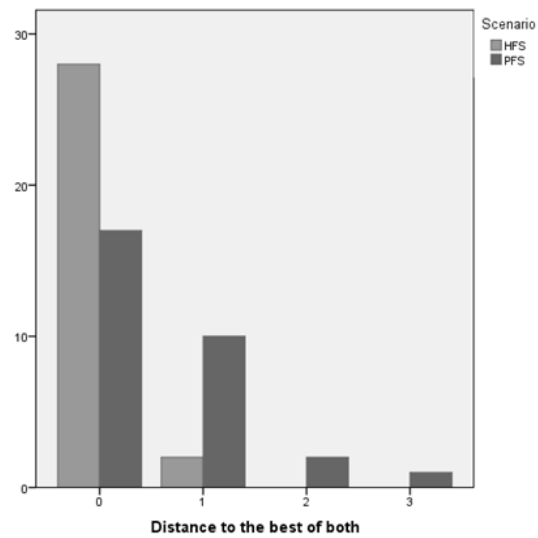

Fig. 6. Difference between both makespan for 1 min. of transportation time

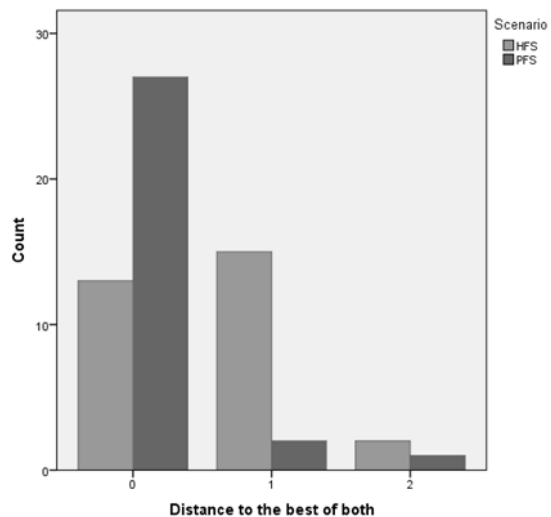

Fig. 7. Difference between both makespan values for 2 min. of transportation time

Table 2. T-Test results (transportation time 1 min.)

	<i>df</i>	<i>Sig. (2-tailed)</i>
Distance to the best of both	52,15	0,001

Table 3. T-Test results (transportation time 2 min.)

	<i>df</i>	<i>Sig. (2-tailed)</i>
Distance to the best of both	35,16	0,002

Using the statistical analysis for this Case 2.1 with scenario 1 the HFS configuration continues to perform better than the PFS, as shown in Figure 6. The Figure 6 shows that for 28 of the 30 problem

instances the best solutions were obtained for the HFS configuration, while for the PFS only 17 times this happens. Therefore the HFS outperforms the PFS configuration 11 times, within this scenario 1.

For scenario 2 the PFS configuration did enable to achieve better performance than the HFS one, as the statistical analysis and Figure 7 show. In fact 27 of the total 30 problem instances, best solutions were obtained for the PFS configuration, while for the HFS only 12 times this happens. Therefore the PFS outperforms the HFS configuration 15 times, within this scenario 2, i.e. 2 minutes of transport time between adjacent workstations.

For being able to better clarify the performance of both configurations (HFS and PFS) considered, two other cases were analyzed (Case3 and Case4), each one including 25 problem instances with 12 jobs, as described next:

Case 3: 25 problem instances with unbalanced work load between both processing stages (operations) for the 12 jobs considered, being the work load around 10% greater in the first processing stage (1st operation) than in the second one.

Case 4: 25 problem instances with unbalanced work load between both processing stages (operations) for the 12 jobs considered, being the work load around 10% greater in the second processing stage (2nd operation) than in the first one.

Figure 8 presents the results obtained for these additional Cases (3 and 4) considered. Through this figure we can realize that the configuration HFS clearly shows advantage by outperforming the PFS configuration PFS in both cases, as in Case 3 the HFS did reach a better makespan 22 times and the PFS configuration just 3 times, and in Case 4 the HFS did reach a better makespan 21 times and the PFS configuration just 2 times and in the remaining 2 runs both configurations did reach a same makespan value in this Case 4.

Through this extended study carried out it is possible to verify that the PFS is just advantageous when the work load between stations is well balanced and that the HFS configuration becomes more advantageous when the work load between stations becomes less homogeneous or unbalanced, as shown through this study based on an industrial case study from an automotive production scenario, which includes 2 work stations (operations) and on which variations of around 10% were added to the first operation in Case 3 and on the second operation in Case 4.

Moreover, we may also realize that we have to be aware that the distribution or inclusion of transport times, in this case considered on both operations or

just in one of them will turn the work load among stations unbalanced and, therefore, affect significantly the results obtained in terms of the quality of the makespan reached by both configurations considered (HFS and PFS).

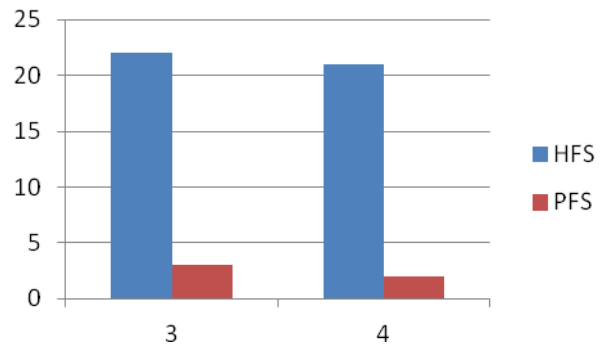

Fig. 8. Number of best solutions (makespan) obtained by both configurations (HFS and PFS) in both cases (3 and 4)

Conclusion

Scheduling is an important and necessary issue to deal with in every production system. Good scheduling ensures good use of resources and timely delivery of orders to customers. Due to the large number of criteria to be considered in scheduling problem, it is recommended to used methods supporting decision-making, which effectiveness is proven in numerous publications [77-81].

Based on an industrial case in this paper we study and compare the makespan performance of two alternative manufacturing systems configurations, namely the Parallel Flow Shop (PFS) and the Hybrid Flow Shop (HFS: The best performing evaluated efficient scheduling algorithm for both was used, i.e. the General Shifting Bottleneck Routine (SBR), available in the scheduling system LEKIN [23].

The study was based on a physical setting that is unchanged, as it is the routing of the jobs' operation to the second stage of manufacturing, provided with a set of identical machines that configures the system to be operated as either a PFS or a HFS configuration.

One important practical conclusion of this study is that system's configuration along with the specification of transportation means/time does influence the overall manufacturing system performance, having an influence on what operating scenario to chose to run the manufacturing system. It means that this factors should be carefully taken into consideration due to its influence on the performance reached by both HFS and PFS configurations.

In general, and also based on a previous study [82] we are able to state, based on an analysis of 25 problem instances of problems of the same extend of 12 jobs, that the PFS performs better than the HFS when the processing times among stages are well balanced and transport times are homogenously distributed over the working stages' processing times but loses advantage, and becomes clearly worse than the performance of the PFS configuration as the working stages' processing times, including or not transport times become less homogeneous and unbalanced.

Therefore, we may state that practitioners must be aware of the importance of transport times and the way these times are considered or added over the working stages' processing times, when operating production systems with direct flow either as Parallel Flow Shops or Hybrid Flow Shops, as this can determine which of this two configurations will be best suited for each production scenario.

The authors intend to apply the approach proposed for studying the performance of different operating systems configurations dependent on job routings and transport times, in a fixed layout of a manufacturing system, to more complex systems, namely for more than two processing stages.

Acknowledgment

This work was supported by National Funds through FCT "Fundação para a Ciência e a Tecnologia" under the program: PEst2015-2020, ref. UID/CEC/00319/2013.

References

- [1] Varela M.L.R., Carmo-Silva S., *An ontology for a model of manufacturing scheduling problems to be solved on the web*, in: Innovation in Manufacturing Networks, ed: Springer, 2008, pp. 197-204.
- [2] Carmo-Silva S., Alves A.C., *Detailed design of product oriented manufacturing systems*, in: Proceedings of the International Conference on Group Technology/ Cellular Manufacturing, 3, Groningen, 2006, Springer.
- [3] Costa J., Varela M.L.R., *Decision System for Supporting the Implementation of a Manufacturing Section on an Automotive Factory in Portugal*, Online Proceedings on Trends in Innovative Computing (ICT 2012), 2012, ISSN: 2150-7996.
- [4] Johnson S.M., *Optimal two and three stage production schedules with setup times included*, Naval research logistics quarterly, vol. 1, pp. 61-68, 1954.
- [5] Garey M.R., Graham R.L., Johnson D.S., *Some NP-complete geometric problems*, in: Proceedings of the eighth annual ACM symposium on Theory of computing, 1976, pp. 10-22.
- [6] Al-Salem A., *A heuristic to minimize makespan in proportional parallel flow shops*, International Journal of Computing & Information Sciences, 2004, vol. 2, p. 98.
- [7] Ruiz R., Vázquez-Rodríguez J.A., *The hybrid flow shop scheduling problem*, European Journal of Operational Research, vol. 205, pp. 1-18, 8/16/ 2010.
- [8] Aneke N., Carrie A., *A design technique for the layout of multi-product flowlines*, International Journal of Production Research, 1986, vol. 24, pp. 471-481.
- [9] Salvador M.S., *A solution to a special class of flow shop scheduling problems*, in: Symposium on the theory of scheduling and its applications, 1973, pp. 83-91.
- [10] Johnson D.S., Garey M.R., *Computers and Intractability-A Guide to the Theory of NP-Completeness*, Freeman&Co, San Francisco, 1979.
- [11] Ribas I., Leisten R., Framiñan J.M., *Review and classification of hybrid flow shop scheduling problems from a production system and a solutions procedure perspective*, vol. 37, ed, 2010, pp. 1439-1454.
- [12] Linn R., Zhang W., *Hybrid flow shop scheduling: a survey*, Computers & Industrial Engineering, vol. 37, pp. 57-61, 1999.
- [13] Haouari M., Hidri L., Gharbi A., *Optimal scheduling of a two-stage hybrid flow shop*, Mathematical Methods of Operations Research, 64(1):107-124, 2006.
- [14] Ruiz R., Maroto C., *A comprehensive review and evaluation of permutation flowshop heuristics*, European Journal of Operational Research, vol. 165, pp. 479-494, September 2005.
- [15] Naderi B., Ruiz R., Zandieh M., *Algorithms for a realistic variant of flowshop scheduling*, Comput. Oper. Res., vol. 37, pp. 236-246, 2010.
- [16] Nowicki E., Smutnicki C., *The flow shop with parallel machines: A tabu search approach*, European Journal of Operational Research, vol. 106, pp. 226-253, 1998.
- [17] Quadt D., Kuhn H., *A taxonomy of flexible flow line scheduling procedures*, European Journal of Operational Research, vol. 178, pp. 686-698, 2007.
- [18] Cheng J., Karuno Y., Kise H., *A shifting bottleneck approach for a parallel-machine flowshop scheduling problem*, Journal of the Operations Research Society of Japan-Keiei Kagaku, 2001, vol. 44, pp. 140-156.
- [19] Zhang X., Van de Velde S., *Approximation algorithms for the parallel flow shop problem*, European Journal of Operational Research, vol. 216, pp. 544-552, 2/1/ 2012.
- [20] Cao D., Chen M., *Parallel flowshop scheduling using Tabu search*, International Journal of Production Research, vol. 41, pp. 3059-3073, 2003.
- [21] Vairaktarakis G., Elhafi M., *The use of flowlines to simplify routing complexity in two-stage flowshops*, IIE Transactions, 2000, vol. 32, pp. 687-699.
- [22] Berliński A., Honczarenko J., *Scheduling manufacturing tasks in EMS discrete programming methods*, scientific work of the Institute of Production Engineering and Automation, University of Technology, No. 41, Wroclaw University of Technology, 2003.
- [23] Pinedo M., *Scheduling: theory, algorithms, and systems*, Springer, 2012.

- [24] Andresen M., Bräsel H., Engelhardt F., Werner F., LiSA-a Library of Scheduling Algorithms: Handbook for Version 3.0: Univ., Fak. für Mathematik, 2010.
- [25] Baker K.R., Baker K.R., *Introduction to sequencing and scheduling*, vol. 15: Wiley New York, 1974.
- [26] Conway R.W., Maxwell W.L., Miller L.W., *Theory of Scheduling*, England: Addison-Wesley Publishing Company, Inc., 1967.
- [27] Lenstra J.K., Shmoys D.B., Tardos E., *Approximation Algorithms for Scheduling Unrelated Parallel Machines*, *Mathematical Programming*, 46, pp. 256-271, 1990.
- [28] Brucker P, *Scheduling Algorithms*, Springer-Verlag, 1995.
- [29] Blazewicz J., Ecker K.H., Pesh E., Schmidt G., Weglarz J., *Scheduling Computer and Manufacturing Process*, Second Edition, Springer, 2001.
- [30] Pinto T., Varela M.L.R., *Comparing Extended Neighborhood Search Techniques Applied to Production Scheduling*, *The Romanian Review Precision Mechanics, Optics & Mechatronics*, (20), No. 37,139-146, 2010.
- [31] Varela M.L.R., Ribeiro R.A., *Evaluation of Simulated Annealing to solve fuzzy optimization problems*, *Journal of Intelligent and Fuzzy Systems*, 14, (2), pp.59-71, 2003.
- [32] Ribeiro R., Varela M.L.R., *Fuzzy optimization using simulated annealing: An Example Set*, in: Verdegay, J-L, (ed.) *Fuzzy Sets Based Heuristics for Optimization*, *Studies in Fuzziness and Soft Computing Series*, 126, Springer, pp. 159-180, 2003.
- [33] Varela M.L.R., Aparício J.N., Carmo-Silva S., *A web-based application for manufacturing scheduling*, *Proceedings of the IASTED International Conference on Intelligent Systems and Control*, 2003, pp.400-405.
- [34] Magalhães R., Varela M.L.R., Carmo-Silva S., *Web-based decision support system for industrial operations management*, *Romanian Review Precision Mechanics, Optics and Mechatronics*, 2010, Vol. 37; pp. 159-165.
- [35] Varela M.L.R., Putnik G.D., Cruz-Cunha M.M., *Web-based Technologies Integration for Distributed Manufacturing Scheduling in a Virtual Enterprise*, *International Journal of Web Portals*, 2012, 4, 2, pp.19-39.
- [36] Vieira G.G., Varela M.L.R., Putnik G., *Technologies Integration for Distributed Manufacturing Scheduling in a Virtual Enterprise*, *Communications in Computer and Information Science*, Vol. 248, p. 345-355, Springer, 2012.
- [37] Varela M.L.R., Barbosa R., Putnik G., *Experimental Platform for Collaborative Inter and Intra Cellular Fuzzy Scheduling in an Ubiquitous Manufacturing System*, *Communications in Computer and Information Science*, 2012, Vol. 248, p. 227-236, Springer.
- [38] Carvalho J.B., Varela M.L.R., Putnik G.D., Hernández J.E., Ribeiro R.A., *A web-based decision support system for supply chain operations management- Towards an Integrd Framework*, *Lecture Notes in Business Information Processing (LNBIP)*, Springer Book of Post Proceedings on "Impact of the Web of Things in Decision Support Systems for Global Environments", F. Dargam, J.E.Hernández, P.Zaraté, S.Liu, R.Ribeiro, B.Delibasic, J. Papatnasiou (Eds.), Springer, 2014.
- [39] Varela M.L.R., Ribeiro R.A., *Distributed Manufacturing Scheduling based on a Dynamic Multi-Criteria Decision Model*, in: *Recent Developments and New Directions in Soft Computing*, Zadeh L.A., Abbasov A. M., Yager R. R., Shahbazova, Sh. N., Reformat M. Z. (Eds.), *Studies in Fuzziness and Soft Computing*, 2014, Vol. 317, pp. 618-623, Springer, Germany.
- [40] Madureira A., Ramos C., Carmo-Silva S., *Resource-oriented scheduling for real world manufacturing systems*, *Assembly and Task Planning*, *Proceedings of the IEEE International Symposium*, pp.140,145, 10-11 July 2003, doi: 10.1109/ISATP.2003.1217201.
- [41] Madureira A., Ramos C., Carmo-Silva S., *A Coordination Mechanism for Real World Scheduling Problems Using Genetic Algorithms*, *IEEE CEC2002*; pp. 175-180, Honolulu, Hawaii, May 2002.
- [42] Madureira A., *Hybrid Meta-heuristics based System for Distributed Dynamic Scheduling*, *Encyclopedia of Artificial Intelligence*, editors: Juan R. Rabuñal, Julian Dorado and Alejandro Pazos, Idea Group Reference, Information Science Reference ISBN: 978-1-59904-849-9, 2008.
- [43] Madureira A., Santos J., *Proposal of multi-agent based model for dynamic scheduling in manufacturing*, *WSEAS Transactions on Information Science & Applications*. 2 (5), pp.600-605, 2005.
- [44] Madureira A., Sousa N., Pereira I., *Self-organization for Scheduling in Agile Manufacturing*, *10th IEEE International Conference on Cybernetic Intelligent Systems 2011 (IEEE CIS 2011)*, London, UK, 1-2 September 2011.
- [45] Madureira A., Pereira I., *Intelligent Bio-Inspired System for Manufacturing Scheduling under Uncertainties*, *International Journal of Computer Information Systems and Industrial Management Applications*, ISSN 2150-7988 Vol. 3, pp.072-079, 2011.
- [46] Madureira A., Santos J., Pereira I., *Hybrid Intelligent System For Distributed Dynamic Scheduling*, published by Springer-Verlag in the series *Natural Intelligence for Scheduling, Planning and Packing Problems*, Series: *Studies in Computational Intelligence*, Vol. 250, Chiong, R.; Dhakal, S. (Eds.), ISBN: 978-3-642-04038-2, 2009.
- [47] Madureira A., Pereira I., Pereira P., Abraham A., *Negotiation mechanism for self-organized scheduling system with collective intelligence*, *Neurocomputing*, Elsevier, 2014, No. 132 pp. 97-110.
- [48] McPherson R.F., White K.P.Jr., *Periodic flow line scheduling*, *International Journal of production Research*, 1998, Vol. 36, No. 1, pp.51-73.
- [49] Muhlemann A.P., Lockett A.G., Farn C.K., *Job shop scheduling heuristics and frequency of scheduling*, *International Journal of Production Research*, 1982, Vol. 20, No. 2, pp.227-241.
- [50] Sun D., Lin L., *A dynamic job shop scheduling framework: A backward approach*, *International Journal of Production Research*, 1994, Vol. 32, No. 4, pp.967-985.
- [51] Buchalski Z., *Heuristic algorithm for scheduling in production systems with parallel machines under resource constraints*, *V1th Conference on Computer Integrated Management*, Zakopane 2004, Scientific-Technical Publisher, 2004.

- [52] Grabowski J., Wodecki M., *New elements simulated annealing algorithm for the problem of flow*, VIth Conference on Computer Integrated Management, Zakopane 2004, Scientific-Technical Publisher, 2004.
- [53] Tanga H., Wong T., *Reactive multi-agent system for assembly cell control*, Robotics and Computer-Integrated Manufacturing, 2004, No. 21 (2005) pp.87–98.
- [54] Susz S., Chebus E., *Methodology of computer-aided simulation of production orders*, VIth Conference on Computer Integrated Management, Zakopane 2004, Scientific-Technical Publisher, 2004.
- [55] Makuchowski M., *Simulated annealing in module problem with multi machines operations that use machine no simultaneously*, VIth Conference on Computer Integrated Management, Zakopane 2004, Scientific-Technical Publisher, 2004.
- [56] Knosala R., *Applications of artificial intelligence*, Scientific-Technical Publisher, 2002.
- [57] Grabowski J., Pampera J., *Doublemachines problem of flow of two operations on the second machine*, VIth Conference on Computer Integrated Management, Zakopane 2004, Scientific-Technical Publisher, 2004.
- [58] Janiak A., Kovalyov M., Portmann Y., *Single machine group scheduling with resource dependent setup and processing times*, European Journal of Operational Research, 2004, Vol.162 (2005), pp. 112–121.
- [59] Coa D., Chena M., Wan G., *Parallel machine selection and job scheduling to minimize machine cost and job tardiness*, Computers & Operations Research, 2003, No. 32 (2005), pp.1995–2012.
- [60] Huang Y.-G., Kanal L. N., Tripathi S. K., *Reactive scheduling for a single machine: Problem definition, analysis, and heuristic solution*, International Journal of Computer Integrated Manufacturing, 1990, vol.3, no.1, pp.6-12.
- [61] Jain A.K., Elmaraghy H.A., *Production scheduling/rescheduling in flexible manufacturing*, International Journal of Production Research, 1997, vol.35, pp.281-309.
- [62] Dhingra J.S., Musser K.L., Blankenship G.L., *Real-time operations scheduling for flexible manufacturing systems*, Proceeding of the 1992 Winter Simulation Conference, 1992, pp. 849-855.
- [63] Henning G.P., Cerda J., *An expert system for predictive and reactive scheduling of multiproduct batch plants*, Latin American Applied Research, 1995, vol.25, pp.187-198.
- [64] Mehta S.V., Uzsoy R.M., *Predictable scheduling of a job shop subject to breakdowns*, IEEE Transactions on Robotics and Automation, 1998, vol.14, pp. 365-378.
- [65] Szelke E., Kerr R., *Knowledge-based reactive scheduling*, Production Planning & Control, 1994, vol.5, no.2, pp. 124-145.
- [66] Jain A. K., Elmaraghy H. A., *Production scheduling/rescheduling in flexible manufacturing*, International Journal of Production Research, 1997, vol.35, pp.281-309.
- [67] Tabe T., Salvendy G., *Toward a hybrid intelligent system for scheduling and rescheduling of FMS*, International Journal of Computer Integrated Manufacturing, 1988, Vol.1, No.3, pp.154-164.
- [68] Yamamoto M., Nof S.Y., *Scheduling/rescheduling in the manufacturing operating system environment*, International Journal of Production Research, 1985, vol.23, no.4, pp. 705-722.
- [69] Sabuncuoglu I., Karabuk S., *Rescheduling frequency in an FMS with uncertain processing times and unreliable machines*, Journal of Manufacturing Systems, 1999, vol.18, no.4, pp. 268-283.
- [70] Dhingra J. S., Musser K. L., Blankenship G. L., *Real-time operations scheduling for flexible manufacturing systems*, Proceeding of the 1992 Winter Simulation Conference, 1992, pp. 849-855.
- [71] Vieira G.E., Herrmann J.W., Lin E., *Analytical models to predict the performance of a single-machine system under periodic and event-driven rescheduling strategies*, International Journal of Production Research, 2000, Vol. 38, No. 8, pp.1899-1915.
- [72] Huang Y.G., Kanal L.N., Tripathi S.K., *Reactive scheduling for a single machine: Problem definition, analysis and heuristic solution*, International Journal of Computer Integrated Manufacturing, 1990, Vol.3, No. 1, pp.6-12.
- [73] Ovacik I.M., Uzsoy R., *Rolling horizon algorithms for a single-machine dynamic scheduling with sequence-dependent setup times*, International Journal of Production Research, 1994, Vol. 32, No. 6, pp.1243-1263.
- [74] Vieira G.E., Herrmann J.W., Lin E., *Predicting the performance of rescheduling strategies for parallel machine systems*, Journal of Manufacturing Systems, 2000, Vol. 19, No. 4, pp.256-266.
- [75] Ovacik I.M., Uzsoy R., *Rolling horizon procedures for dynamic parallel machine scheduling with sequence-dependent setup times*, International Journal of Production Research, 1995, Vol. 33, No. 11, pp.3173-3192.
- [76] Gahagan S.M., *Simulation and optimization of production control for lean manufacturing transition*, Dissertation submitted to the Faculty of the Graduate School of the University of Maryland, 2008.
- [77] Arrais-Castro A., Varela M., Putnik G., Ribeiro R., Dargam F., *Collaborative negotiation platform using a dynamic multi-criteria decision model*, International Journal of Decision Support System Technology, Vol. 7, Issue: 1, pp. 1-14, 2015, DOI: 10.4018/ijdsst.2015010101.
- [78] Diering M., Hamrol A., Kujawińska A., *Measurement system analysis Combined with Shewhart's Approach*, Key Engineering Materials Vol. 637, pp 7-11, 2015, ©Trans Tech Publications, Switzerland, DOI:10.4028/www.scientific.net/KEM.637.7
- [79] Kujawinska, A., Rogalewicz, M., Diering, M., Piłacińska M., Hamrol A., Kochański A., *Assessment of ductile iron casting process with the use of the DRSA method*, Journal of Mining and Metallurgy Section B-Metallurgy, Vol. 52, Issue 1, pp.25-34, 2016, DOI:10.2298/JMMB150806023K.
- [80] Kujawińska A., Rogalewicz M., Diering M., Hamrol A., *Statistical Approach to Making Decisions in Manufacturing Process of Floorboard*, In: Proc. of 5th World Conf. on Information Systems and Technologies, Recent Advances in Information Systems and Technologies, Springer, vol. 3, 499–508 (2017); doi: 10.1007/978-3-319-56541-5_51\
- [81] Vieira G.,Varela M., Putnik G., Machado J., *An integrated framework for supporting fuzzy decision-making in networked manufacturing environments*,

Romanian Review Precision Mechanics, Optics and Mechatronics, Issue 48, pp. 85-91, 2015.

- [82] Costa N.M.L., Varela M.L.R., Carmo-Silva S., *Scheduling in product oriented manufacturing systems*, Proceedings of the Sixth World Congress on Nature and Biologically Inspired Computing (NaBIC), IEEE, 2014, pp. 196-201.