



Manel Hlaili, Amira Haddouk, Khaoula Khelifi, Mechergui Hfaiedh, Vítor Monteiro, João L. Afonso

“Three-Phase Smart Energy Meter for Grid-Connected PV Installations,”

EAI SESC International Conference on Sustainable Energy for Smart Cities, Braga, Portugal, Dec. 2019.

Three-Phase Smart Energy Meter for Grid-Connected PV Installations

Manel Hlaili¹, Amira Haddouk¹, Khaoula Khelifi¹, Mechergui Hfaiedh¹,
Vítor Monteiro², João L. Afonso²

¹Research Laboratory: LISIER,
Ecole Nationale Supérieure des Ingénieurs de Tunis, University of Tunis, Tunisia
²ALGORITMI Research Centre- University of Minho Guimarães - Portugal
hlaili_manel@yahoo.fr

Abstract. High levels of solar energy are a good orientation for the development of grid-connected power converters used in the interface of photovoltaic (PV) installations with the power grid. In this case, in order to define control strategies and the respective tariffs, the injected power into the grid must be accounted using an energy meter. Therefore, in this paper, the implementation of a three-phase smart energy meter for PV installations is presented, ensuring the registration of the electrical energy supplied to the grid. This three-phase energy meter consists of Hall-effect sensors, used to adapt the high voltages and currents with the analog circuits of the signal conditioning, which is connected to a DSP. The developed energy meter ensures data acquisition and processing and, based on that, the energy calculation and standardization in real time. As presented along the paper, a detailed metrology analysis was developed to identify the smart meter metrological characteristics. Through the experimental validations, it was possible to validate the main features of the developed smart energy meter for grid-connected PV installations.

Keywords: Photovoltaic; Energy Meter; DSP; Metrological Analysis.

1 Introduction

Solar photovoltaic (PV) installations can make significant contributions towards to solve some of the most energy problems that we are facing, nowadays, around the world. Power demand is continuously increasing; however, the electricity utilities are unable to meet this rapidly increasing demand. Solar PV systems, which are used to convert sunlight into electricity, are increasing, are pollution free, and are a renewable energy source. The power is produced by directly transforming a free and unlimited energy source into electricity. However, in order to benefit from a PV installation, variables as the cost of installation and the system efficiency are extremely relevant. Typically, the electricity generated from a solar PV installation is injected into the grid, after conditioning to suit all the conditions of the grid integration [1]. The power produced by the PV system can be consumed by the user, where the PV system is

installed, or can be injected into the grid, similar to a nuclear power plant or a hydroelectric power plant, but with a lower value of injected power [2].

A system of double counting (purchase-sale) makes it possible to resell the power produced in extra, as well as to consume the available power in the grid when there is no Sun. The unit is entirely automated and managed by a controlled power electronics converter. Thus, the context of this type of managed installation is based on the intermittent power production associated with the non-controllable profile consumption, which is difficult to anticipate. In fact, it is the independent factor (the energy from the sun depends of the weather conditions) which restricts the power consumption from the PV. The energy produced by PV modules is directly consumed by the pay loads and the possible production overflow is injected into the grid. Indeed, the energy context and the gas emissions regulations for greenhouse effects, as well as the fossil energy resources reduction, compel us to support renewable energy installations, such as PV systems [3].

This article deals with the necessity of an energy meter to be installed into a solar PV system connected to the grid. From the physics point of view, the power produced by the solar PV system is consumed in priority by local loads (in this case a silo) and only the surplus power is injected into the grid. Thus, a three-phase smart energy meter has been designed for such purpose, which is a subject that has recently attracted a pertinent attention with many advantages and projects around the world due to the technical feasibility in several countries.

2 Proposed Solution Used for the Energy Meter

Fig. 1 shows a block diagram of the solar PV system interfaced with the power grid, where the block diagram of “system connection to the grid” represents the contactors and switch breakers. The strategy used to measure the total active power is following described.

The voltage and current signals of each phase of the grid are used as input for a multiplier, model AD734, which is followed by a digital low-pass filter. Using the voltage and current signals, as well as the output voltage of each multiplier, it is calculated, respectively, the voltage and current RMS values and the power. The total power is:

$$P_t = P_1 + P_2 + P_3 \quad (1)$$

According to Fig. 2, the power feed by each phase can be calculated as following described. At the Hall-effect sensors (voltage and current) output we have:

$$v_{1v}(t) = k_v \cdot V_{1M} \cdot \cos(\omega t) \quad (2)$$

$$v_{1I}(t) = k_I \cdot I_{1M} \cdot \cos(\omega t - \phi) \quad (3)$$

It is important to note that at the output of each sensor (voltage and current) is obtained a voltage signal proportional to the measured voltage or current at the input side.

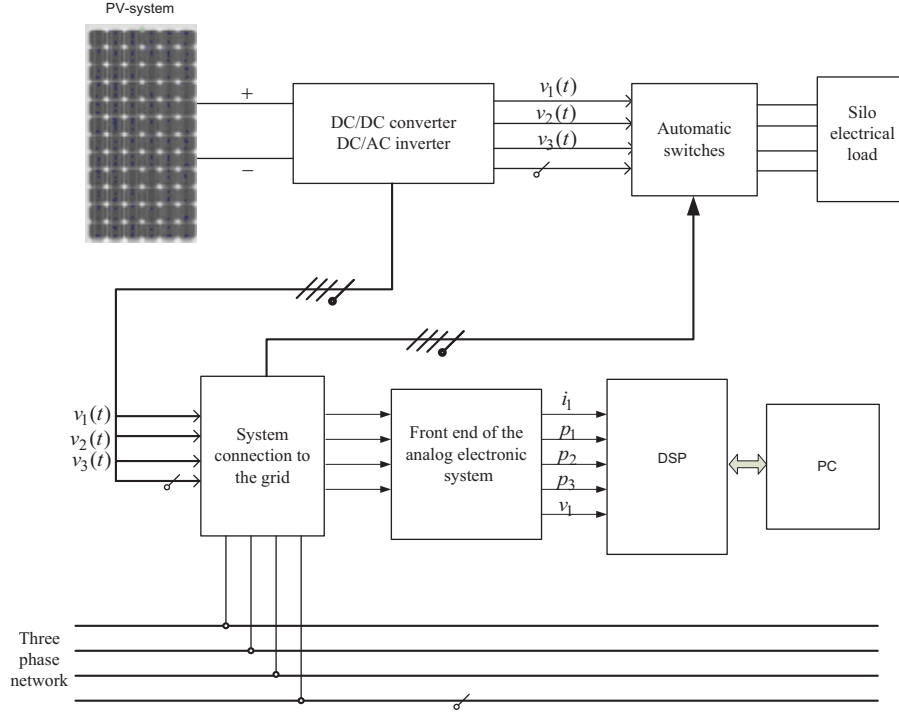

Fig. 1: Block diagram of the solar PV system:
Connection to the grid with the energy meter.

Therefore, the output voltages $v_{1V}(t)$ and $v_{1I}(t)$, relative to each phase of the grid, are applied to the AD734 multiplier, which gives at its output their product, according to:

$$v_{xy} = \frac{k_I \cdot k_V \cdot k_{xy} \cdot V_{1M} I_{1M} \cdot \cos(\phi)}{2} + \frac{k_I \cdot k_V \cdot k_{xy} \cdot V_{1M} I_{1M} \cdot \cos(2\omega t - \phi)}{2} \quad (4)$$

or

$$v_{xy} = k_p [P_0 + p_{ac}(t)] \quad (5)$$

where:

$$k_p = \frac{k_V k_I k_{xy}}{2};$$

P_0 : represent the active power;

$p_{ac}(t)$ represent the alternative power component.

If $v(t)$ and $i(t)$ are not sinusoidal, we have:

$$v(t) = \sum_{n=1}^{\infty} V_n \cos(n\omega t - \phi_n) \text{ and } i(t) = \sum_{n=1}^{\infty} I_n \cos(n\omega t - \phi_n)$$

To extract the average power, we use an RC filter which performs an integration function. Using the trigonometric transform as:

$$\cos \alpha \times \cos \beta = \frac{1}{2} \cos(\alpha - \beta) + \frac{1}{2} \cos(\alpha + \beta) \quad (6)$$

then the average power consumed by the load is:

$$P = \frac{1}{T} \sum_{n=1}^{\infty} \frac{V_n I_n}{2} \int_0^T (\cos(\phi_{nv} - \phi_{ni}) + \cos(2n\omega t - \phi_{nv} - \phi_{ni})) dt \quad (7)$$

$$p = \sum_{n=1}^{\infty} \frac{V_n I_n}{2} \cos(\phi_{nv} - \phi_{ni}) \quad (8)$$

The power exchange is performed when $v(t)$ and $i(t)$ are with the same frequency (fundamental component). To increase the acquisition system accuracy, we acquired the signal at the multiplier (AD734) output, and then we use a digital low-pass filter, instead of an analogue filter. The system acquires a number M of samples during a time $T_m = M.T_s$, so the power is:

$$P = \frac{1}{k_p} \frac{1}{M} \sum_{i=1}^M v_{xy}(i) \quad (9)$$

Knowing the values of active power, voltage and current, for each phase of the grid, it is calculated the apparent power, defined by:

$$S = V.I \quad (10)$$

and the phase angle, defined by:

$$\varphi = \cos^{-1}\left(\frac{P}{S}\right). \quad (11)$$

To determine the energy, the power is summed with an integral time of 1 second, such as:

$$W(j) = \sum_{i=1}^{\infty} P_{0i} \times t_i \quad (12)$$

The conversion to kWh is given by:

$$W(kWh) = W(j) \times \frac{1}{10^3 \times 3600} \quad (13)$$

The current and voltage acquisition are performed as following described. Since the output voltage sensor presents a sinusoidal signal, a DC component is added in order to acquire these variables by the digital controller :

$$v_{v-acq}(t) = V_{dc} + v_v(t) \quad (14)$$

To extract $v_v(t)$, it's necessary first to read sampled data from the ADC and store it in a location in the Static Random Access Memory (SRAM), where it cannot be overwritten by new data. The first task to perform on the data is then to remove any DC offset. This is carried out calculating the mean value as:

$$\bar{v}_{acq} = \frac{1}{N} \sum_{n=1}^N v_{acq}(n) \quad (15)$$

$$V_{v-acq-RMS} = \frac{1}{N} \sqrt{\sum_{n=1}^N v_{acq}^2(n)} \quad (16)$$

Then, the RMS value is given by:

$$V_{v-RMS} = \sqrt{V_{v-acq-RMS}^2 - \bar{v}_{acq}^2} \quad (17)$$

The RMS grid voltage and current are:

$$V_{RMS} = \frac{1}{k_V} V_{v-RMS} \quad (18)$$

$$I_{RMS} = \frac{1}{k_I} V_{I-RMS} \quad (19)$$

The electric energy measurement and management was performed via a DSP. This last is used, also, for the solar PV system management feeding a wheat silo. It has excellent performance in terms of speed and digital analogue acquisition means, so we have exploit it to conceive a smart energy meter, which has several interesting metrological futures. Fig.2 shows the electronic part of the energy meter. The control algorithm used to determine the energy is shown in Fig. 3.

3 Metrological Analysis

The validity of this study must be completed by a detailed metrological analysis to illustrate the energy meter performance [5,6]. The prototype hardware architecture brings up two parts: (a) A measurement chain using Hall-effect sensors (voltage and current) and a multiplier matching circuit; (b) An intelligent system ensuring the acquisition and processing, as well as data transmission to a PC using a USB port [4]. This system delivers the voltage and current RMS values, as well as the values of active, reactive, and apparent power, and energy (U , I , P , Q , S and W).

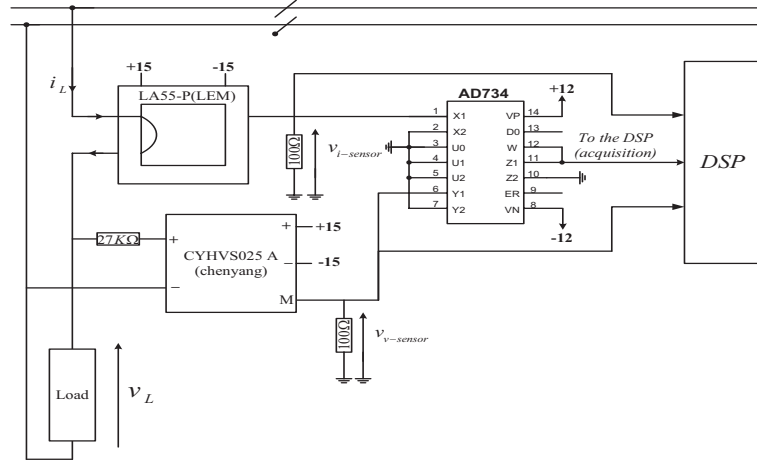

Fig. 2: Electronic part of the three-phase smart energy meter.

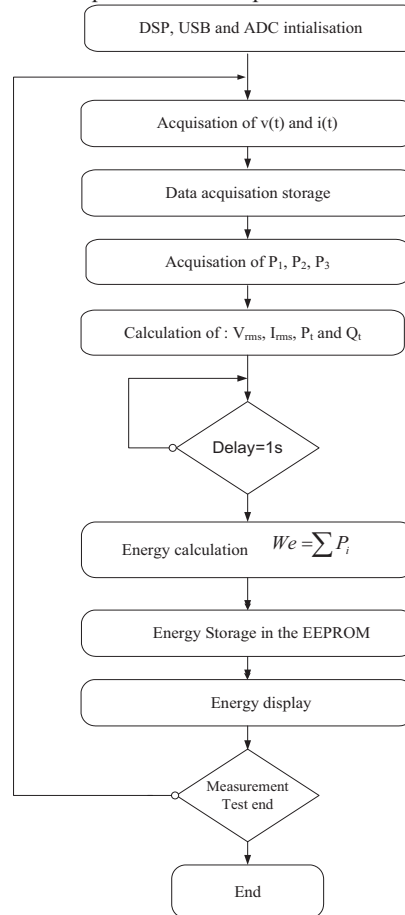

Fig. 3: Control algorithm used to determine the energy.

The information about the measured variables goes through different circuits before being processed and displayed. The signal to be processed, by the DSP, is first digitalised as:

$$V_{xy-acq} = k_p \cdot P = \frac{V_{ref}}{2^n} N_x \quad (20)$$

From (18) we calculate the power P:

$$P = \frac{q}{k_p} N_x \quad (21)$$

where:

$q = \frac{V_{ref}}{2^n}$: is the quantum (or analogue resolution of the ADC);

n : the number of bits;

N_x : the decimal conversion number.

Knowing k_p and acquiring v_{xy} , v_V , and v_I , so the power load the voltage and current RMS values and the energy consumed are determined during a time Δt .

To estimate the precision measurements, the schematic diagram presented in Fig.4 is used.

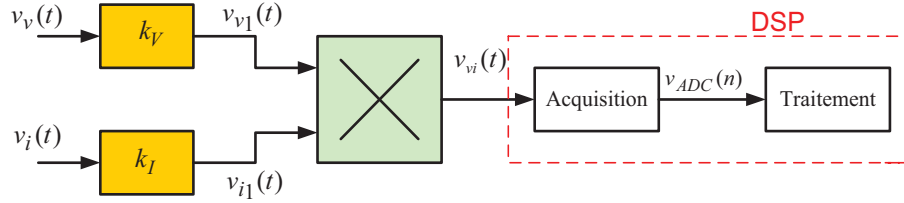

Fig. 4: Schematic diagram for acquiring the variables using the DSP.

The analogue to digital converter (ADC) performs the signal samples at the multiplier output. The ADC introduces a noise due to the quantization that can be represented by the following modelling. Fig. 5 shows the ADC modelled schematic diagram.

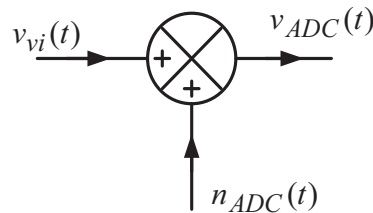

Fig. 5: ADC modelled schematic diagram.

$$v_{ADC}(t) = v_{vi}(t) + n_{ADC}(t) \quad (22)$$

Then:

$$v_{ADC}(t) = \frac{1}{2} k_V k_I k_{xy} V_{M_1} I_{M_1} (\cos(\varphi_v - \varphi_i) + \cos(2\omega t + \varphi_v + \varphi_i)) + n_{mult}(t) + n_{ADC}(t) \quad (23)$$

The estimated power average value is determined by dividing Equation (22) with the term $k_V k_I k_{xy}$, which gives:

$$P = \frac{2}{k_V k_I k_{xy}} \frac{1}{M} \sum_{i=1}^M v_{ADC}(iT_e) \quad (24)$$

For the aquisition an ADC of 12 bits and a reference DC voltage of 3.3 V is used. So its quantum (q) is equal to:

$$q = \frac{V_{ref}}{2^{12}} = \frac{3.3}{4096} = 0.810 [mV] \quad (25)$$

The parameters involved in Eq. (25) are independent. Then we use the error propagation method:

$$\sigma p = \sqrt{\left(\frac{\partial p}{\partial q}\right)^2 (\sigma q)^2 + \left(\frac{\partial p}{\partial k_p}\right)^2 (\sigma k_p)^2} \quad (26)$$

From Eq. (27), which gives the error variance, the uncertainty error due to the measurement system is evaluated:

$$\frac{\sigma_p}{p} = \sqrt{\left(\frac{\sigma q}{q}\right)^2 + \left(\frac{\sigma k_V}{k_V}\right)^2 + \left(\frac{\sigma k_I}{k_I}\right)^2 + \left(\frac{\sigma k_{xy}}{k_{xy}}\right)^2} \quad (27)$$

$$\frac{\sigma_p}{p} (\%) = \sqrt{\sum \left(\frac{\sigma x_i}{x_i}\right)^2} \times 100 \quad (28)$$

Sensors with an accuracy of 0.1% and a multiplier with an accuracy of 0.2% are selected. After all calculations and using an auto calibration system for each data acquisition operation, the error propagation can be less than 0.4 % for a voltage range of 230 V per phase and a current range of 20 A.

4 Experimental Results

To validate the theory, a smart energy meter was developed and tested in the Power Electronics Laboratory (Group of Energy and Power Electronics, GEPE) at the Uni-

versity of Minho, Portugal. All the acquisitions are processed by a DSP and then transferred to a PC via USB. In terms of implementation, the Hall-effect sensors ensure galvanic isolation and measurement accuracy, and the smart energy meter offers a versatile voltage and current connections from 50 V to 400V AC up to 100 A. The experiment results are presented in following graphs. Fig. 6 shows the workbench of the energy meter.



Fig. 6: Workbench of the energy meter.

5 Conclusion

In this paper, a smart energy meter is presented, this last allows to measure, in real time, the power injected into the power grid from a solar photovoltaic (PV) installation. The developed system has the flexibility and the ability to be changed in order to be adapted for various electrical environments. Indeed, the proposed method consists in using analog multipliers and the extraction of the power information is performed by a sliding average digital filter. This method is easier to implement and requires lower computation resources. For the energy meter design, a metrological evaluation has been developed and treated. The designed energy meter can serve any other application in residential or industrial sectors.

Acknowledgments

This work has been supported by FCT – Fundação para a Ciência e Tecnologia within the Project Scope: UID/CEC/00319/2019. This work is financed by the ERDF – European Regional Development Fund through the Operational Programme for Competitiveness and Internationalisation – COMPETE 2020 Programme, and by National Funds through the Portuguese funding agency, FCT – Fundação para a Ciência e a Tecnologia, within project SAICTPAC/0004/2015 – POCI – 01–0145–FEDER–016434.

6 References

1. F. Spertino, G. Graditi, "Power conditioning units in grid-connected photovoltaic systems: A comparison with different technologies and wide range of power ratings," *Solar Energy*, 108:219–229, October 2014.
2. H. Manel, "Development and control of power electronics for a photovoltaic power generation system for on-grid off-grid operation," Thesis: Electrical Engineering, Tunis, High National School of Engineers of Tunis, January 2017.
3. H. Iwata, K. Okada, "Greenhouse gas emissions and the role of the Kyoto Protocol," «Graduate School of Global Environmental Studies, Kyoto University, Japan, April 2010.
4. S. Bhaskar, S. Sreenivasulu, B. Polaiiah, "Intelligent system for single phase energy meter billing and action taking using wireless network," *International Journal of Advanced Information and Communication Technology*, vol.1, pp.446-451, 2014.
5. Sapna G, Pravesh G. Prepaid, "Energy meter for billing system using microcontroller and recharge card," *International Journal of Core Engineering and Management*, vol.1, pp.12-18, 2014.
6. Khaoula Khelifi, Amira Haddouk, Ahlem Ayari, Hfaiedh Mechergui, "Measurement of active power, electrical energy, and TRMS voltage and current using the dual slope conversion technique," *Turkish Journal of Electrical Engineering & Computer Sciences*, January 2018.
7. Ayari Ahlem, Mechergui Hfaiedh, Haddouk Amira, Hlaili Manel, "Developing a Novel Method: Calculating the Deformation Factor to Control Energy Consumption," 3rd International Conference on Green Energy and Environmental Engineering (GEEE) - Proceedings of Engineering & Technology (PET), pp.68-75, 2016.