



“Lessons learned” of the transdisciplinary ProChild CoLAB Research Project

Summer School “Neckar Now III: Transformative approaches to a sustainable future – cities for children”

Cidália Silva (UM/EA/Lab2PT/ProChild CoLAB)

Gabriela Trevisan (ProChild CoLAB), Mariana Carvalho (ProChild CoLAB), Diana Amaral (UM/EA/Lab2PT)

23 . 08 . 2022

Prochild

collaborative laboratory

R&D units

Social Intervention Area

Health and well
being



Development and
Education



Social
participation



Protection



Technology Development Area

Digital technology



Nanotechnology



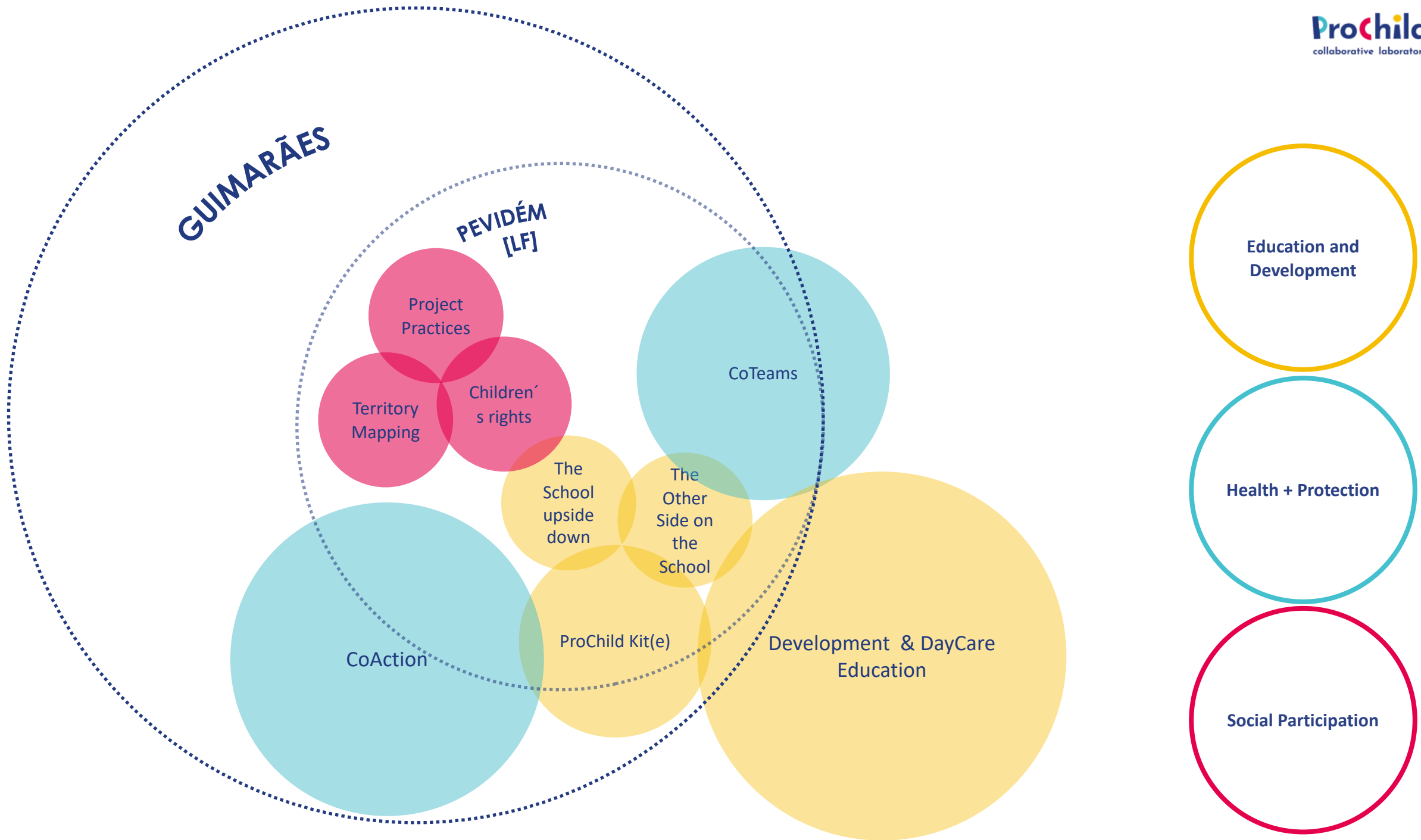



Travessa da Saudade, Pevidém, Guimarães, 2019

The *Learning field* concept

- The Pevidém *Learning Field* seeks to transform the space-time of children, acting in its material and immaterial dimensions, based on models of urban transformation, oriented towards children.
- The focus *is on the child*, but the actions mobilize children, families, teachers and social action of an interdisciplinary team (architects, social workers, psychologists, cultural agents, health professionals).
- The rationale behind the project is based on the idea that the territory, as a common living space, can and should be educational, favoring learning and promoting citizenship and the well-being of children and families.
- Main actions include Intervention in public spaces, training programs for local agents, child social participation and initiatives to promote children's rights.

Our Learning Field: Pevidém

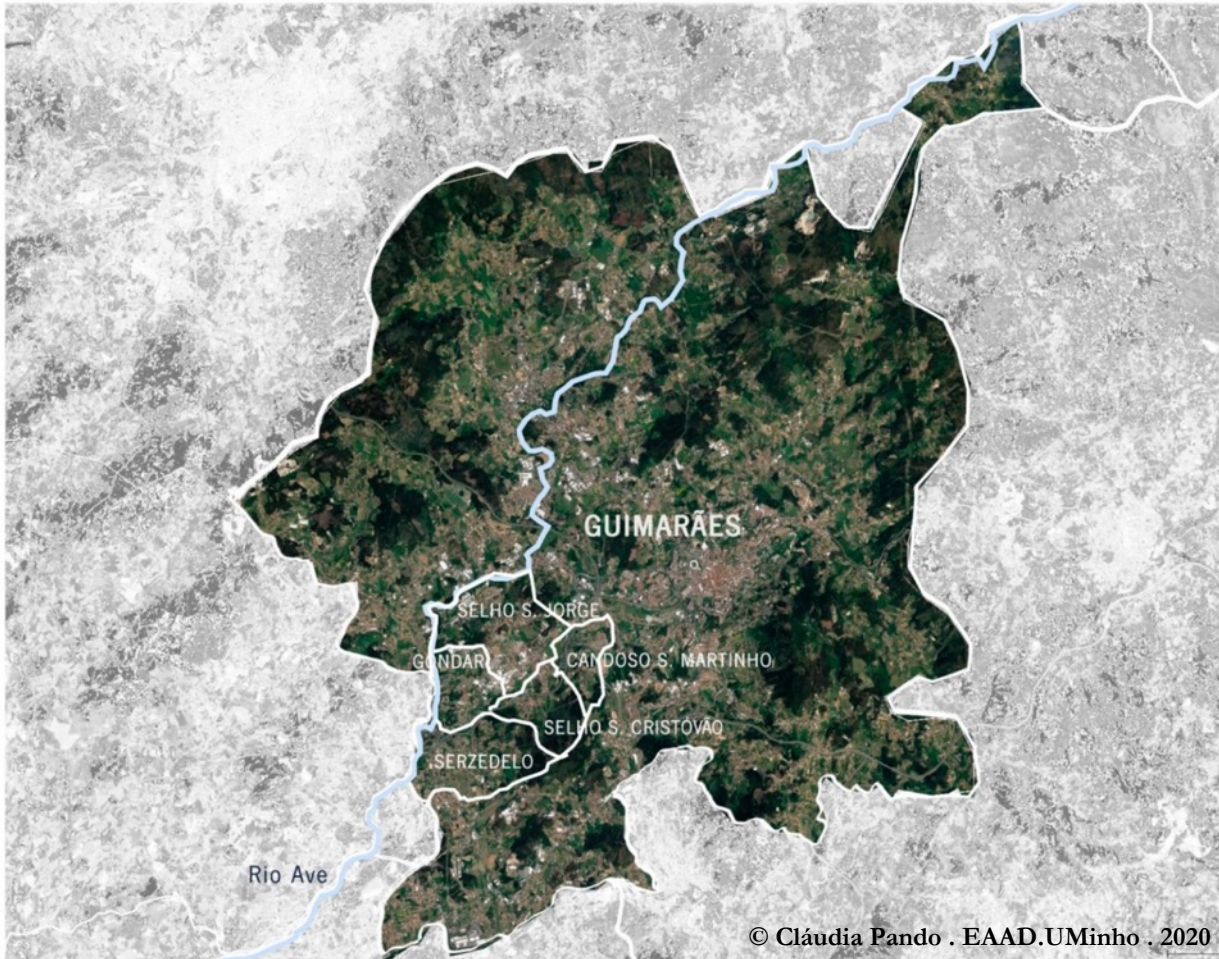

Pevidém as a Learning Field, Guimarães

- Guimarães Region, which corresponds to the parishes of the Pevidém Group of Schools, with a total of 15,453 people (Census 2021).
- This territory has been affected by every crisis in the textile industry, with cyclical unemployment, high emigration and precarious working conditions.
- Threats to the quality of the family environment, school performance and children's development and well-being.

Approach based on the *Learning Field* inside the community, promoting social participation and improving leisure and cultural life, focused on the child

0 to 3 years old

6 to 10 years old

6 to 16 years old

Development & Education in Daycare

Improvement of educational practices and support in children's development in daycare contexts



Desenvolvimento e Educação

Early Childhood Education

Learning is a +

(Inês Guedes de Oliveira, Teresa Freire, Gabriela Bento, Gabriela Trevisan, Mariana Carvalho)

Promoting non formal education and transformation of school spaces



Desenvolvimento e Educação



Participação social

Non formal Education

Territory Mapping





(Manuel Sarmiento, Natália Fernandes, Cidália Silva, Gabriela Trevisan, Mariana Carvalho)

Action research methodologies on children and young people participation, on their ways of appropriation of collective space

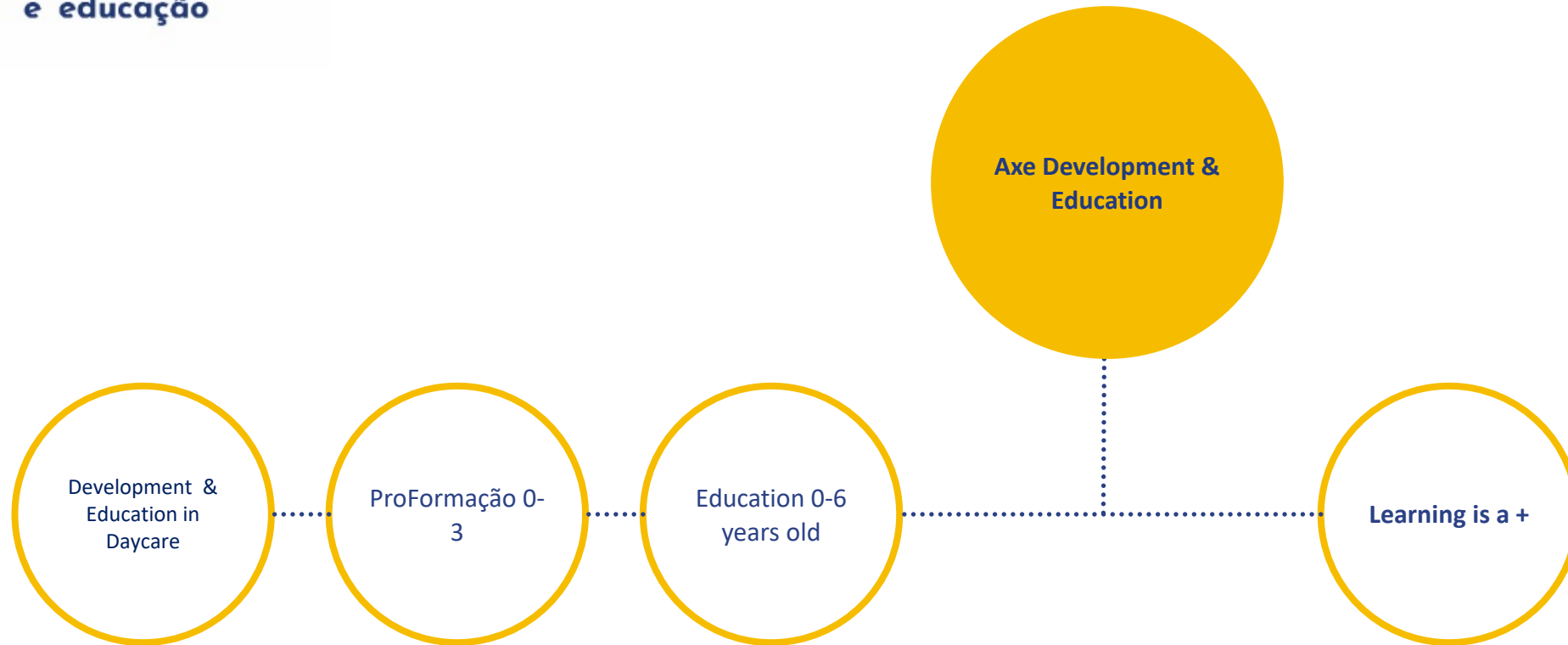

Participação social



- ProChild Kit(e) 
- The School Upside down 
- The Other Side of the School 
- Moving Kids 





ESCOLA DE PERNAS PARA O AR:
GUIAS DA ESCOLA
EB1/J.I. Cruzeiro / Gondar (Guimarães)
"As Sapatinhas Brancas"
Guias:
Pr. de J.



Escola EB1, Gondar, 2020
© Porta 7 . Ana Martins





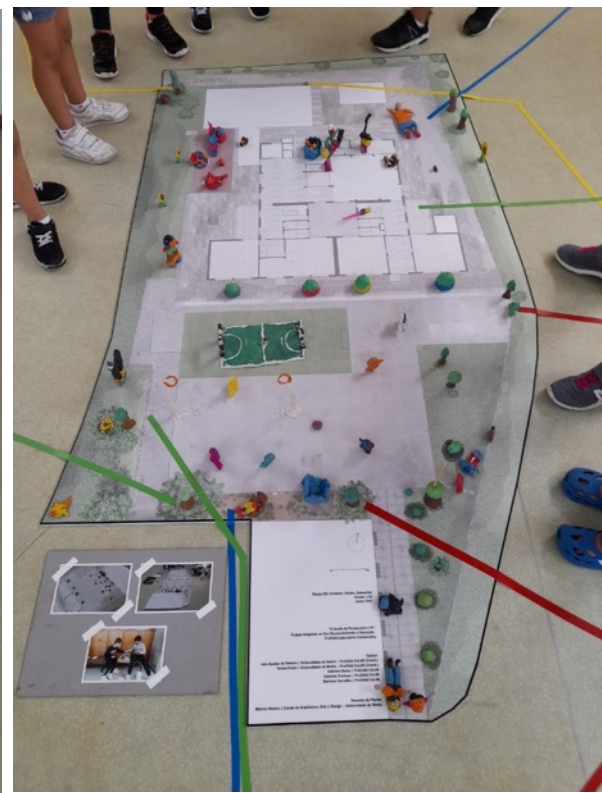

Escola EB1, Gondar, 2021
© ProChild CoLAB, Mariana Carvalho



A ESCOLA DE PERNAS PARA O AR

ESCOLA EB1 EIRINHA
3º e 4º ano junho 2022
EXPOSIÇÃO DO PROJETO

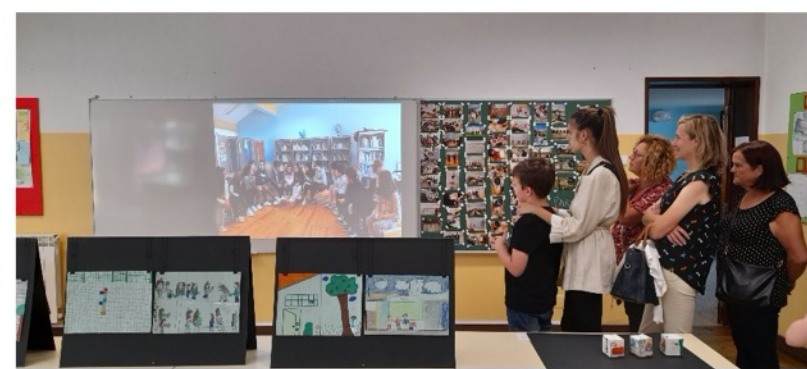





Grade
 • Macaquinho do chinês

Trajetória da Flot
 (equilíbrio)

Macaça (bêi)

jogo do Galo
 (humano com os pés e mãos)

Macaça (até ao 10)

Banheiros das entradas
 • pista de carros
 • fazem lama e colocam nos copos de iogurte

Paredes (2 postes)
 • chutam a bola 3x 1m de bater entre os postes (por ordem alfabética)

Escadas
 • lanchar
 • brincam às irmãs

Escadas
 • espetáculos (dança, canto e teatro)
 • bancada (assistem aos jogos)
 • polícias e ladrões
 • atiram a bola de cima e os de baixo apanham

Parede lateral do edifício
 • jogo do Murinho (pontapé na bola e tim de toca numa parte específica da parede)

Mesa (1/3 tronco e tábuas)
 • pedra, papel e tesoura
 • lanches
 • cozinham com folhas e paus

Lequeinho

Terra junto da rede
 • casinhas (desenham as divisões da casa)

Libe junto da rede
 • escondem objetos e procuram.

Campo de basquetebol
 (jogam também futebol)

Castelo
 (onde a bola vai e sobem para a ir buscar)

Margem do campo
 • brincam com o que trazem de casa (slime)
 • à caça caça

Campo de futebol
 • jogam futebol
 • jogam Lura → (apurar à próxima fase)
 • jogam fuita → (guarda-redes começa com 21 pontos, se o jogador marcar pontapé de bicicleta, o guarda-redes perde 10 pontos
 " " " " 5 "
 " de calcanhar " " " " 1 "



Play map



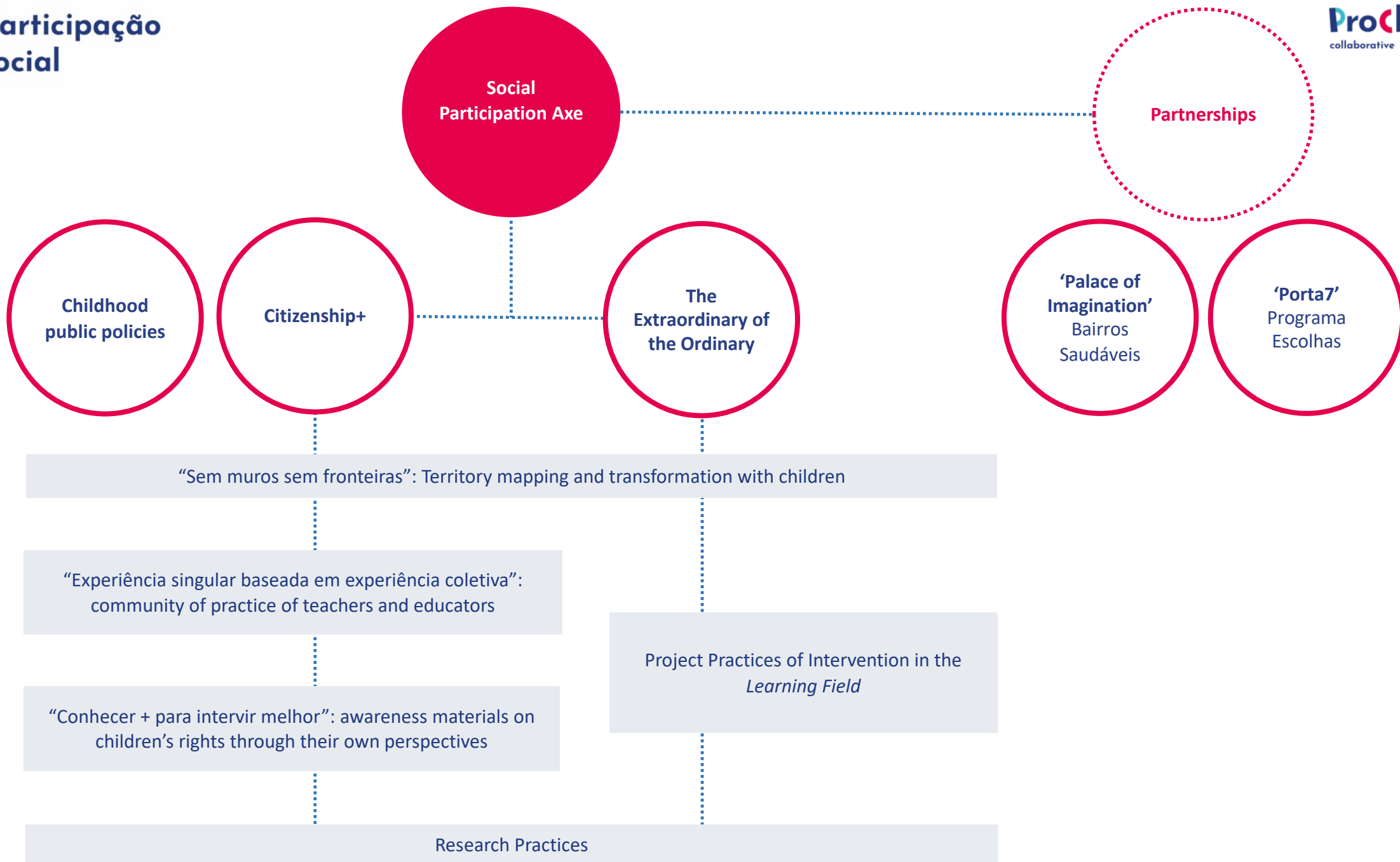

Approach based on a *Learning Field* inside the community in order to promote social participation and improve leisure and cultural life, on a child centered perspective.

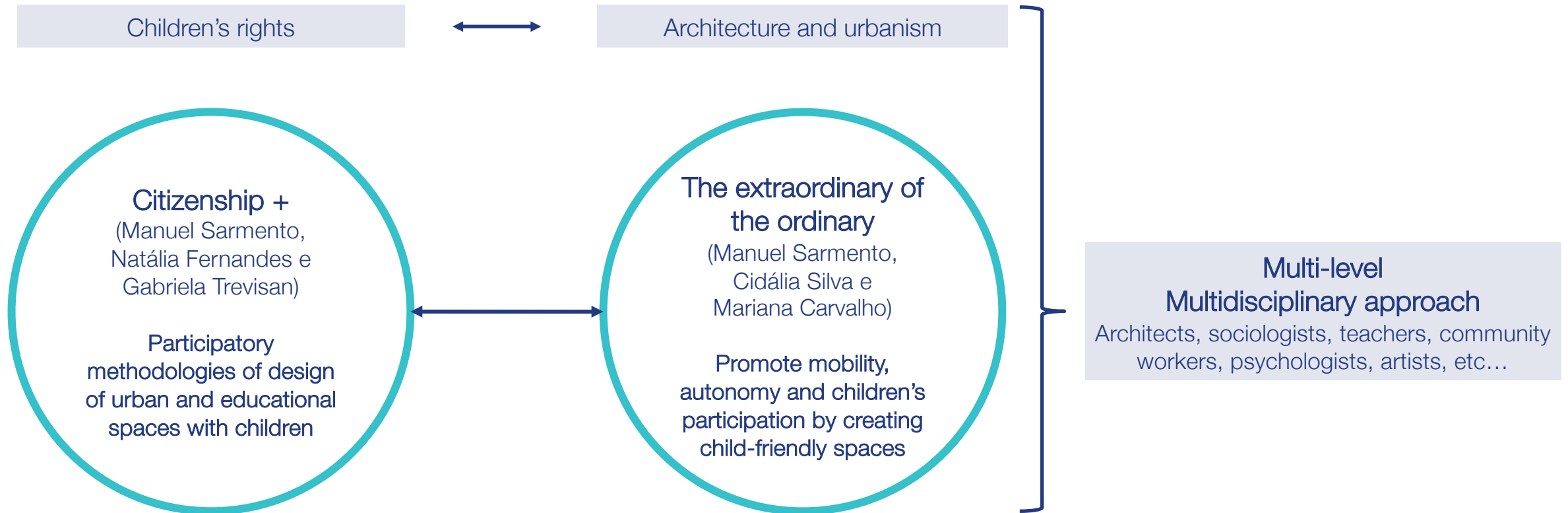

“Sem muros nem fronteiras”: Territory Mapping and transformation with children

Habito este Lugar | I inhabit this place | Bairro da Emboladoura | September 2020

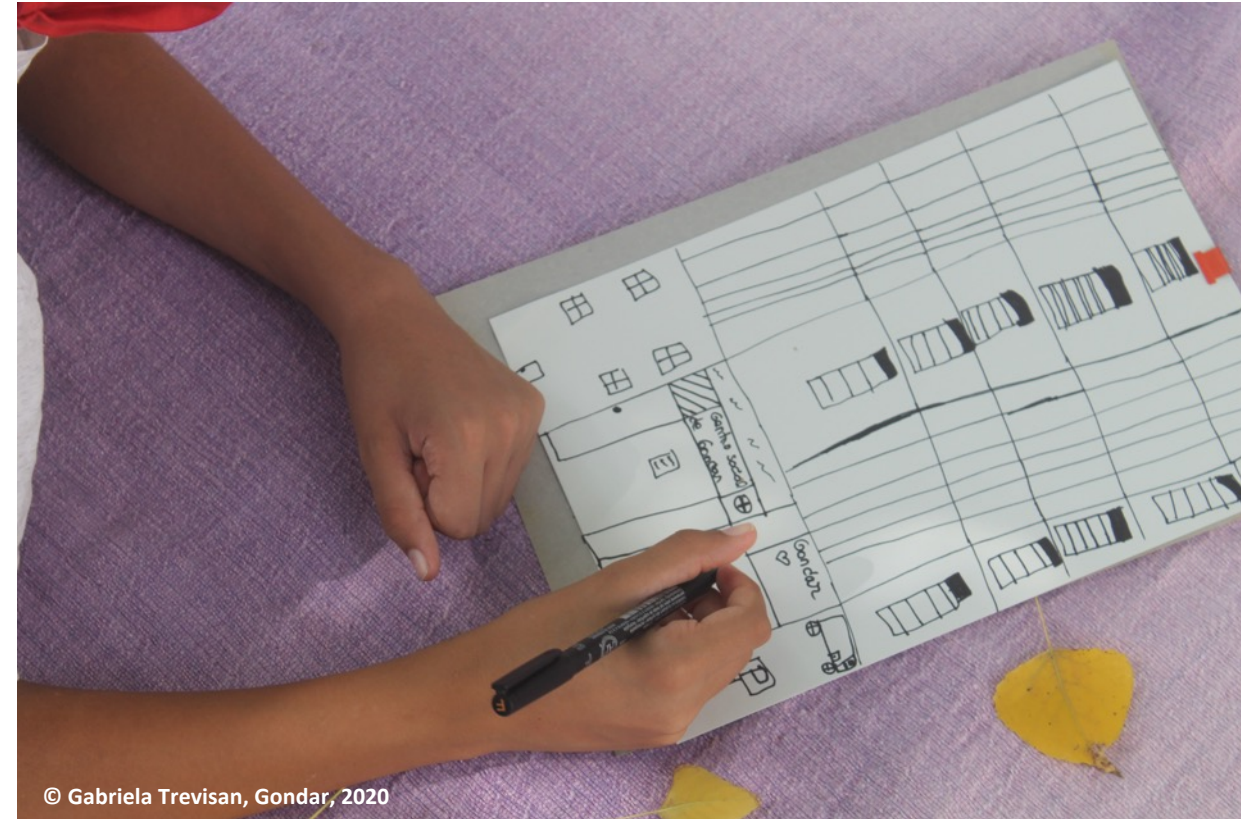
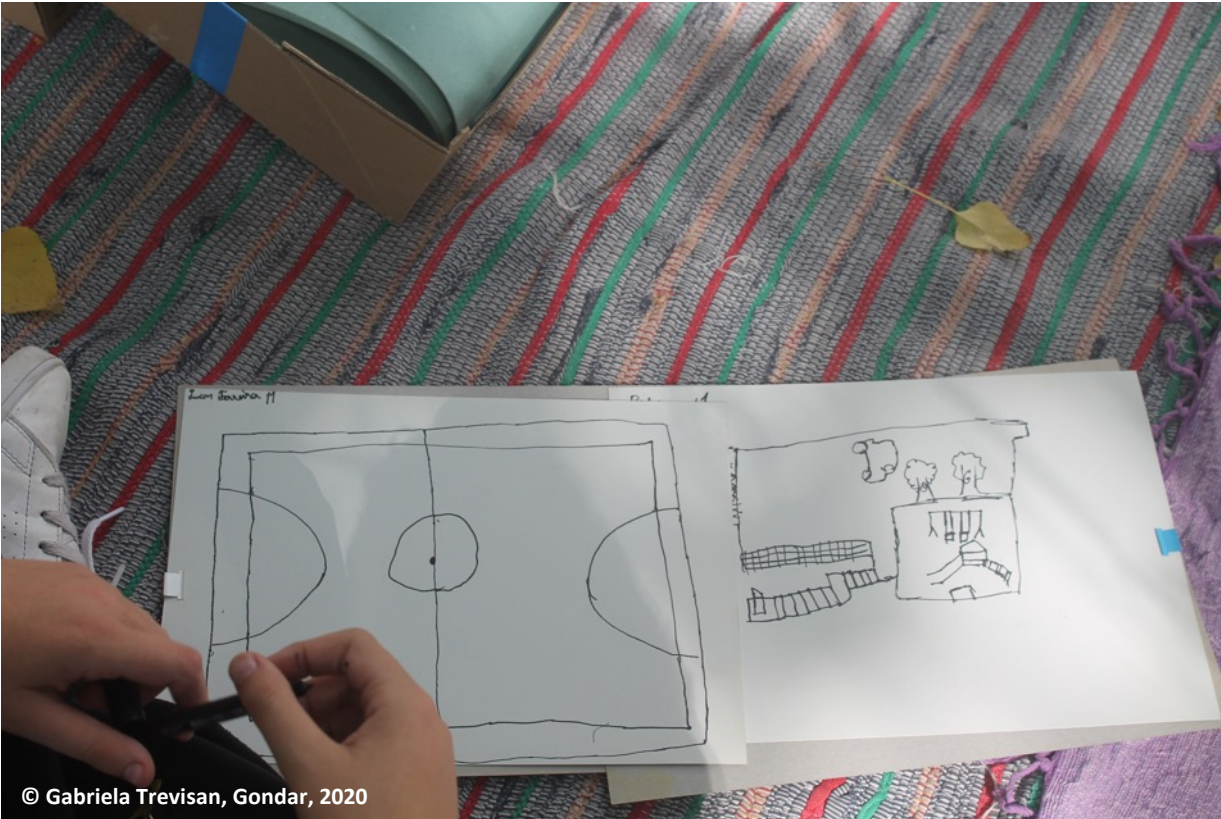

Partnership with local intervention projects - Porta7/ Fraterna

Mapping exercises and territory recognition with children

“Sem muros nem fronteiras”: Territory Mapping and transformation with children

Habito este Lugar | I inhabit this place | Bairro da Emboladoura | September 2020

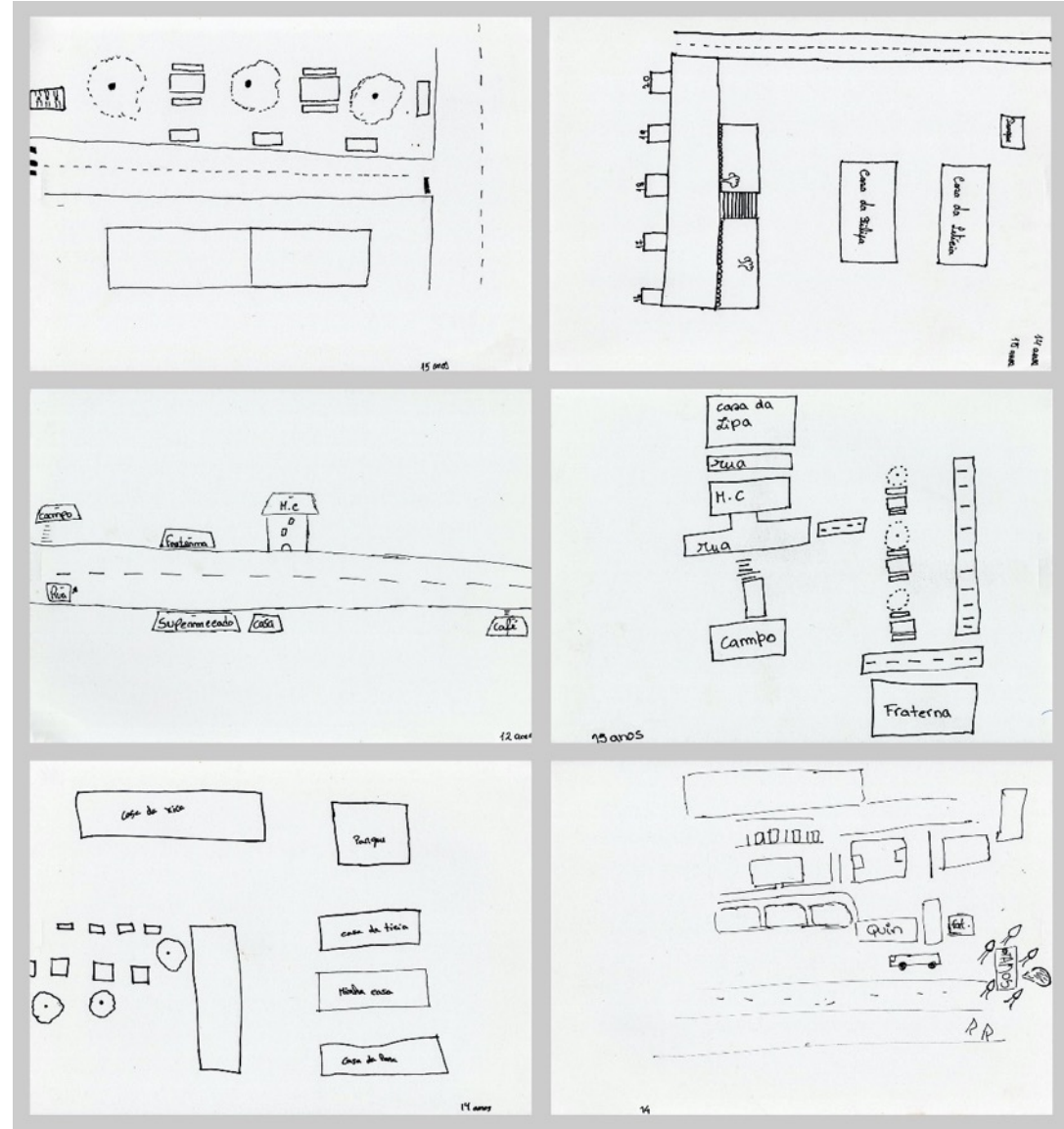
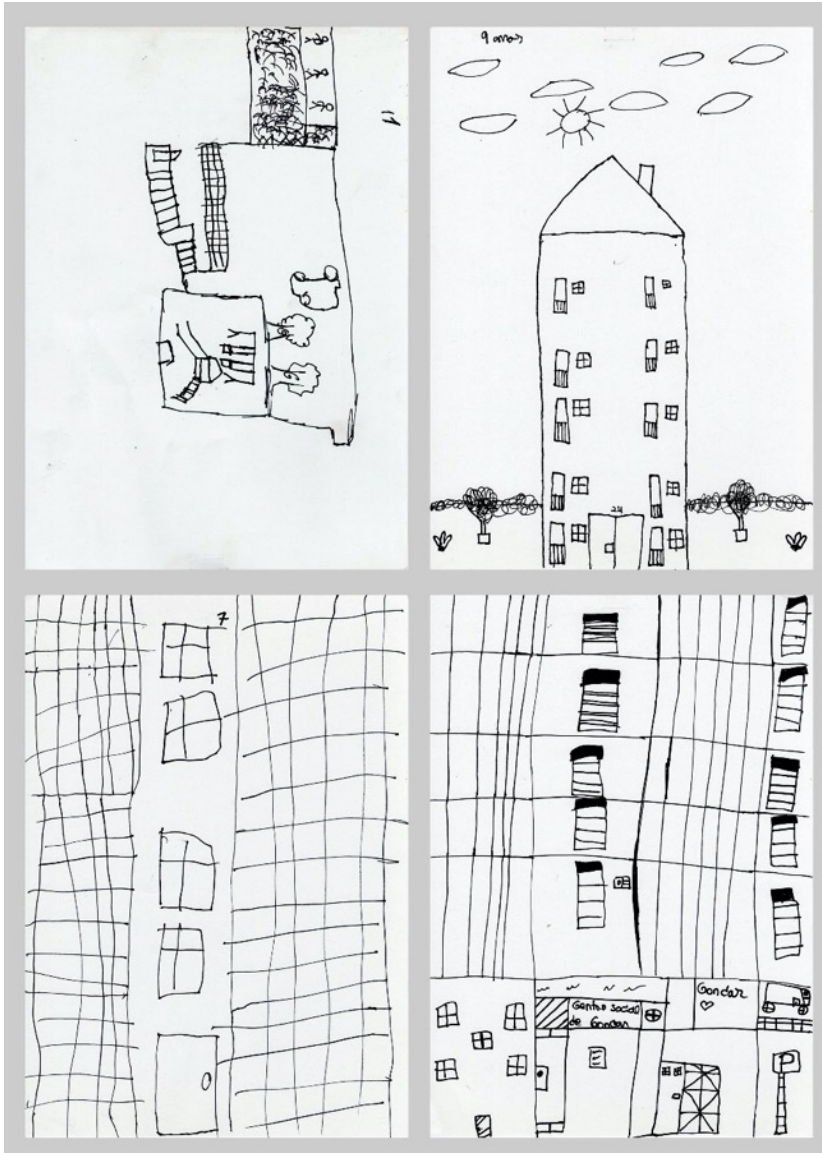

“Sem muros nem fronteiras”: Territory Mapping and transformation with children

Habito este Lugar | I inhabit this place | Bairro da Emboladoura | September 2020



© Gabriela Trevisan, Gondar, 2020

© Gabriela Trevisan, Gondar, 2020

“Sem muros nem fronteiras”: Territory Mapping and transformation with children

Habito este Lugar | I inhabit this place | Bairro da Emboladoura | September 2020



“Sem muros nem fronteiras”: Territory Mapping and transformation with children

Habito este Lugar | I inhabit this place | Bairro da Emboladoura | September 2020

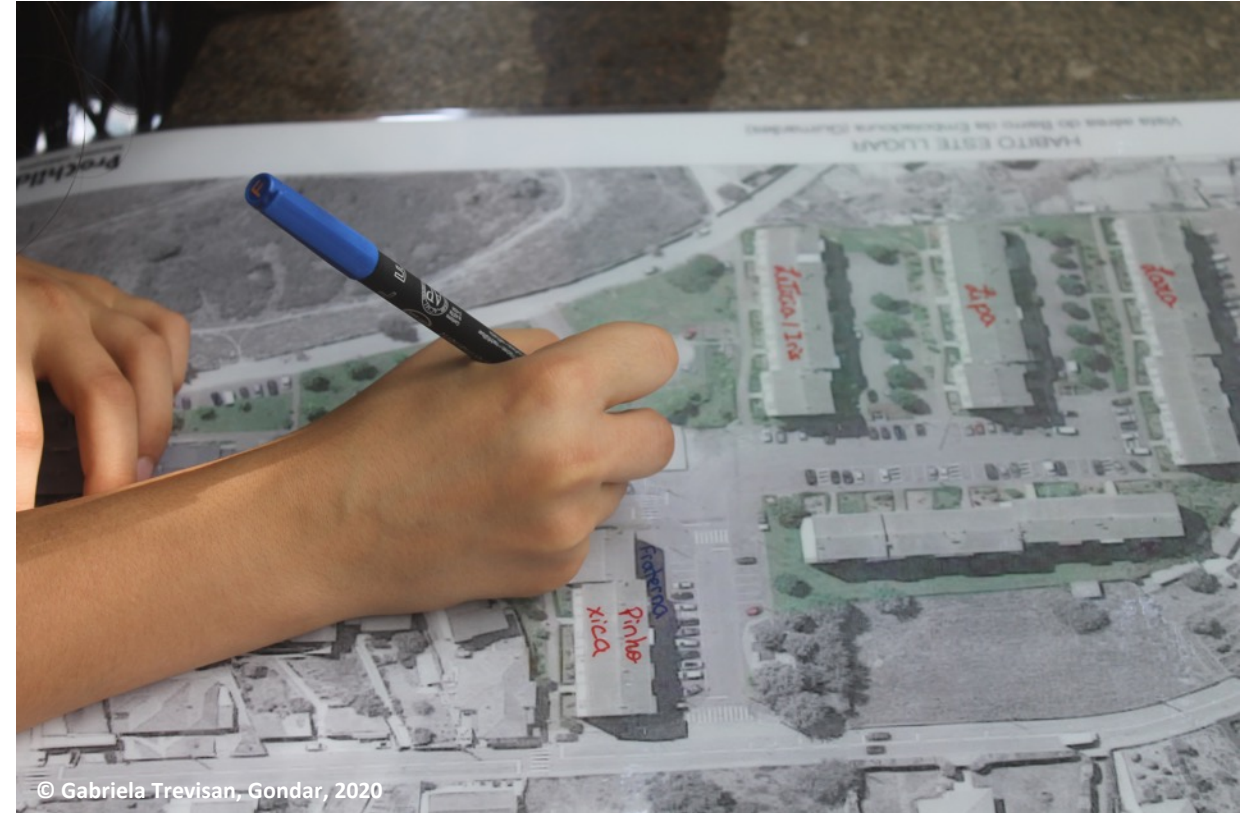

“Sem muros nem fronteiras”: Territory Mapping and transformation with children

Habito este Lugar | I inhabit this place | Bairro da Emboladoura | September 2020

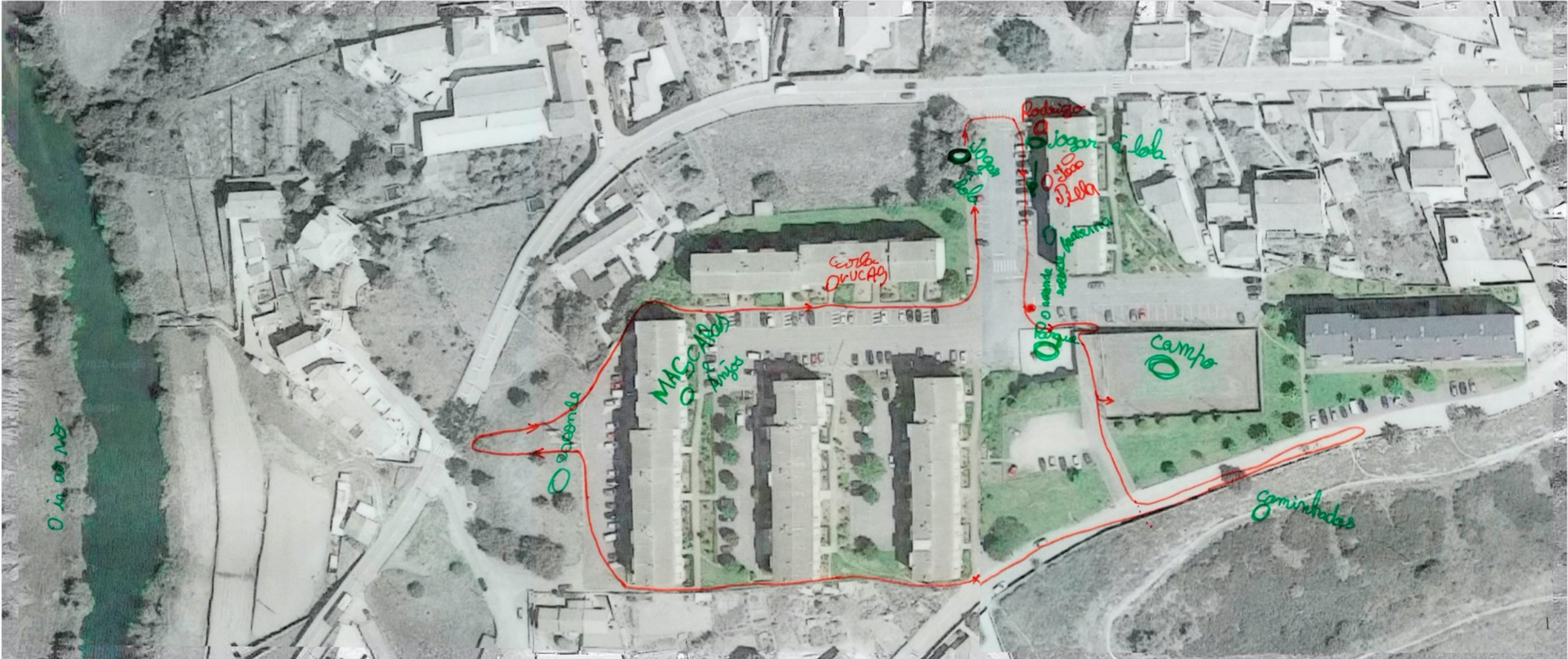

HABITO ESTE LUGAR

Vista aérea do Bairro da Emboladoura (Guimarães)

“Sem muros nem fronteiras”: Territory Mapping and transformation with children

Habito este Lugar | I inhabit this place | Bairro da Emboladoura | September 2020

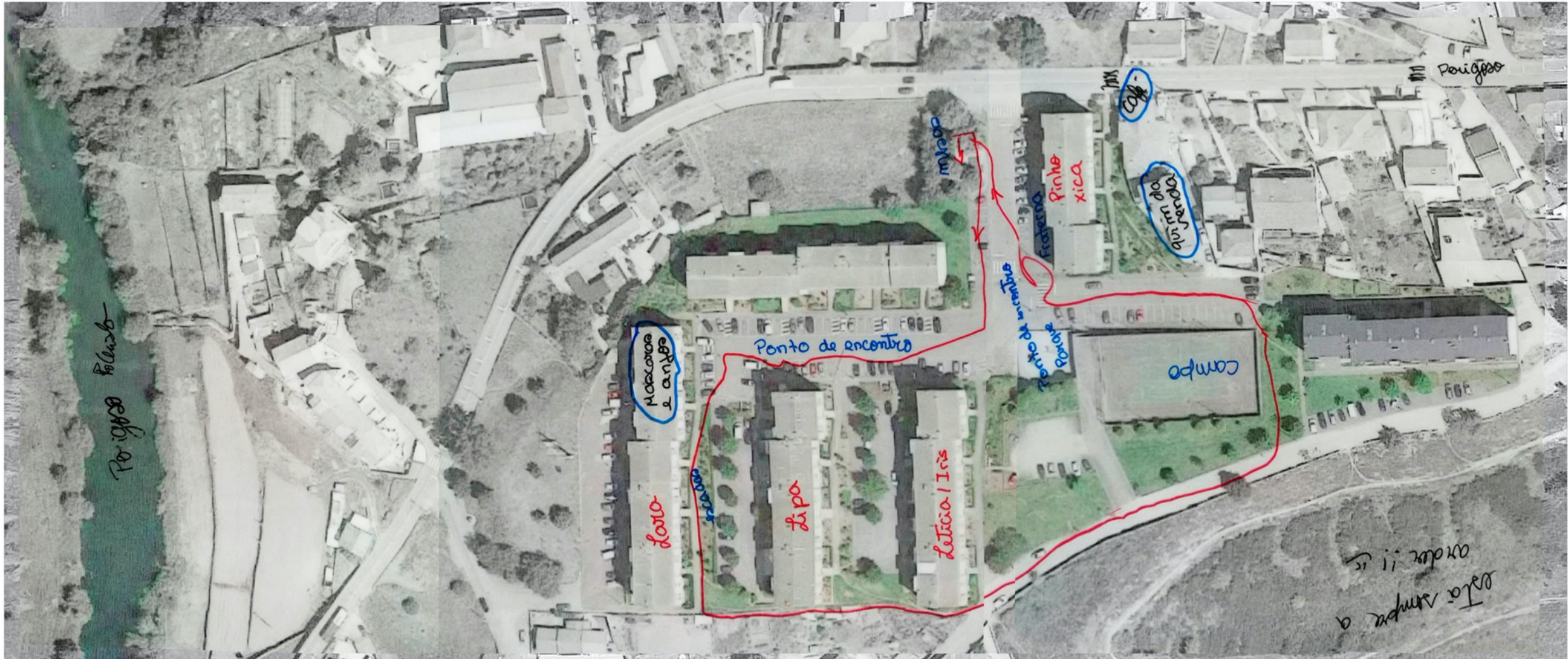

HABITO ESTE LUGAR

Vista aérea do Bairro da Emboladoura (Guimarães)

“Sem muros nem fronteiras”: Territory Mapping and transformation with children

Imagino este Lugar | I imagine this place | Bairro da Emboladoura | April to July 2021





“Sem muros nem fronteiras”: Territory Mapping and transformation with children

Imagino este Lugar | I imagine this place | Bairro da Emboladoura | April to July 2021



“Sem muros nem fronteiras”: Territory Mapping and transformation with children

Imagino este Lugar | I imagine this place | Bairro da Emboladoura | April to July 2021



“Sem muros nem fronteiras”: Territory Mapping and transformation with children

Imagino este Lugar | I imagine this place | Bairro da Emboladura | April to July 2021



“Sem muros nem fronteiras”: Territory Mapping and transformation with children

Imagino este Lugar | I imagine this place | Bairro da Emboladoura | April to July 2021



“Sem muros nem fronteiras”: Territory Mapping and transformation with children

Imagino este Lugar | I imagine this place | Bairro da Emboladura | April to July 2021

O que não gostamos

- A areia.
- O balaço
- Segurança do escorreg.
- poluição
- muros - muros
- paredes
- cercas

O que queremos mudar no Parque

- mais arvoredo
- mais sombra
- mais bancos
- mais brinquedos
- mais jogos
- mais espaço

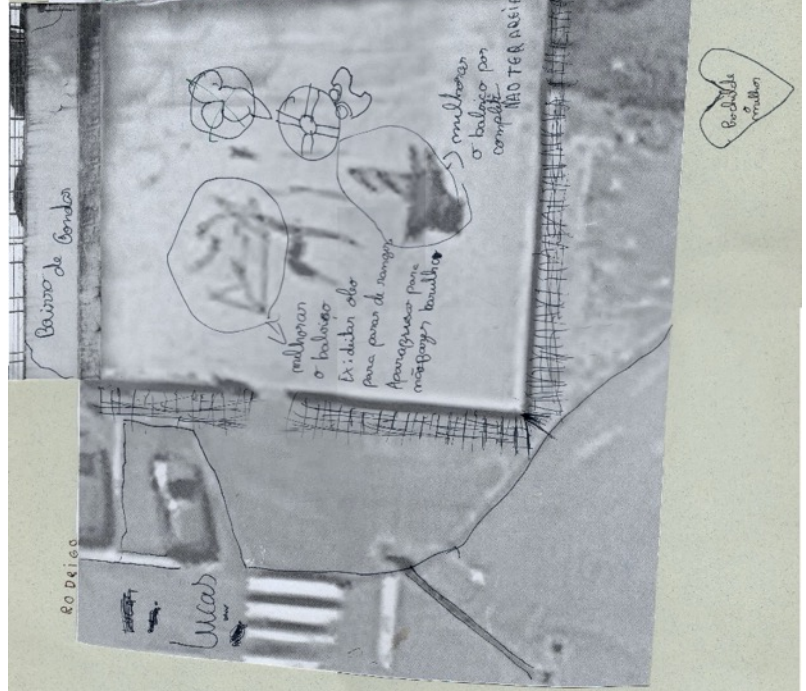

O que nós gostamos

- o chão ✓
- Os balaços ✓
- O escorreg ✓
- placa de poluição ✓
- sombras/bancos ✓
- muros altos ✓
- casinha / corral ✓
- mais balaços ✓
- pintar os muros / parede ✓

O que nós queremos melhorar

- maior. (aumentar) ✓
- melhorar a porta ✓
- fluminação ✓
- tabua/prancha que balaço ✓
- lixa ✓
- bebedouro ✓
- mesas / cadeiras ✓
- desinfetante ✓

O que nós gostamos

- mais verde
- mais sombra
- mais espaço

O que podemos mudar...

- mais ter deenho para as parede
- mais ter comil
- aumentar a taf

O que não gostamos

- A areia.
- O balaço
- Segurança do escorreg.
- poluição
- muros - muros
- paredes
- cercas

O que nós queremos melhorar

- maior. (aumentar) ✓
- melhorar a porta ✓
- fluminação ✓
- tabua/prancha que balaço ✓
- lixa ✓
- bebedouro ✓
- mesas / cadeiras ✓
- desinfetante ✓

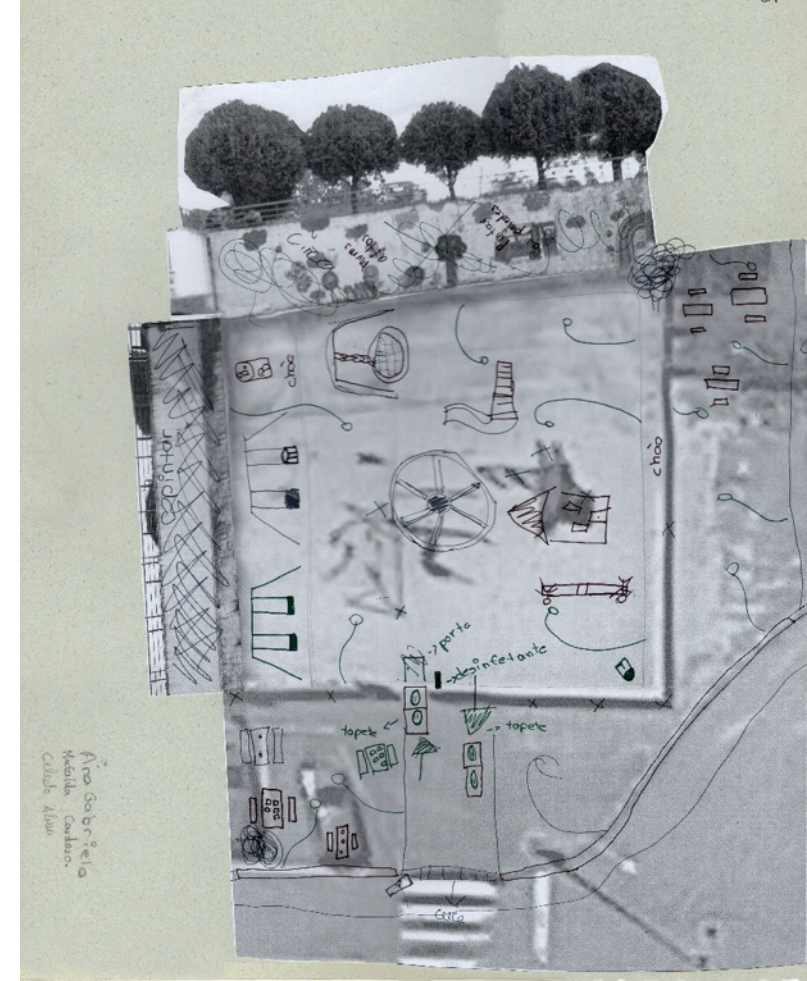

“Sem muros nem fronteiras”: Territory Mapping and transformation with children

Imagino este Lugar | I imagine this place | Bairro da Emboladoura | April to July 2021



“Sem muros nem fronteiras”: Territory Mapping and transformation with children

Imagino este Lugar | I imagine this place | Bairro da Emboladoura | April to July 2021



“Sem muros nem fronteiras”: Territory Mapping and transformation with children

Imagino este Lugar | I imagine this place | Bairro da Emboladoura | April to July 2021

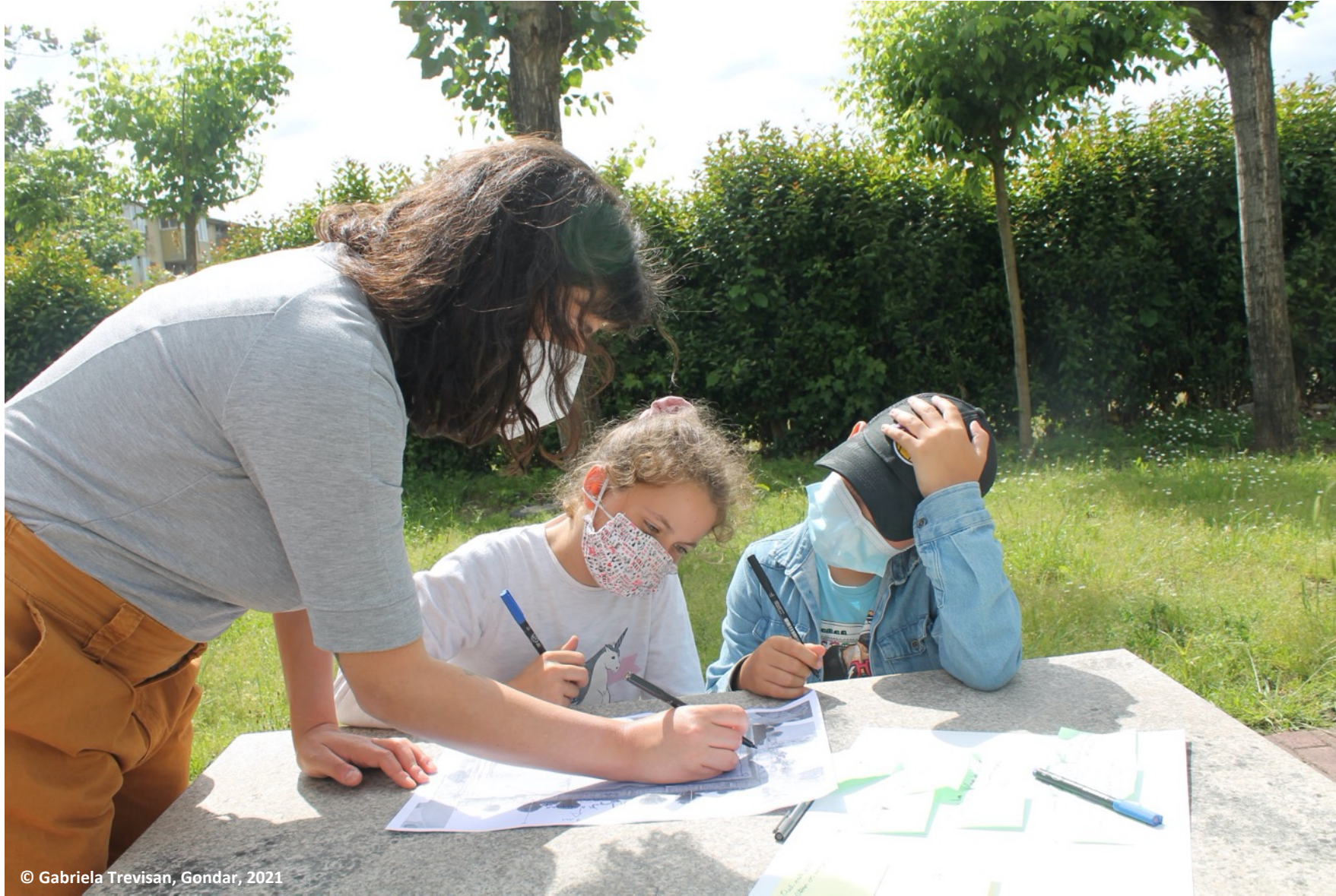

“Sem muros nem fronteiras”: Territory Mapping and transformation with children

Imagino este Lugar | I imagine this place | Bairro da Emboladoura | April to July 2021

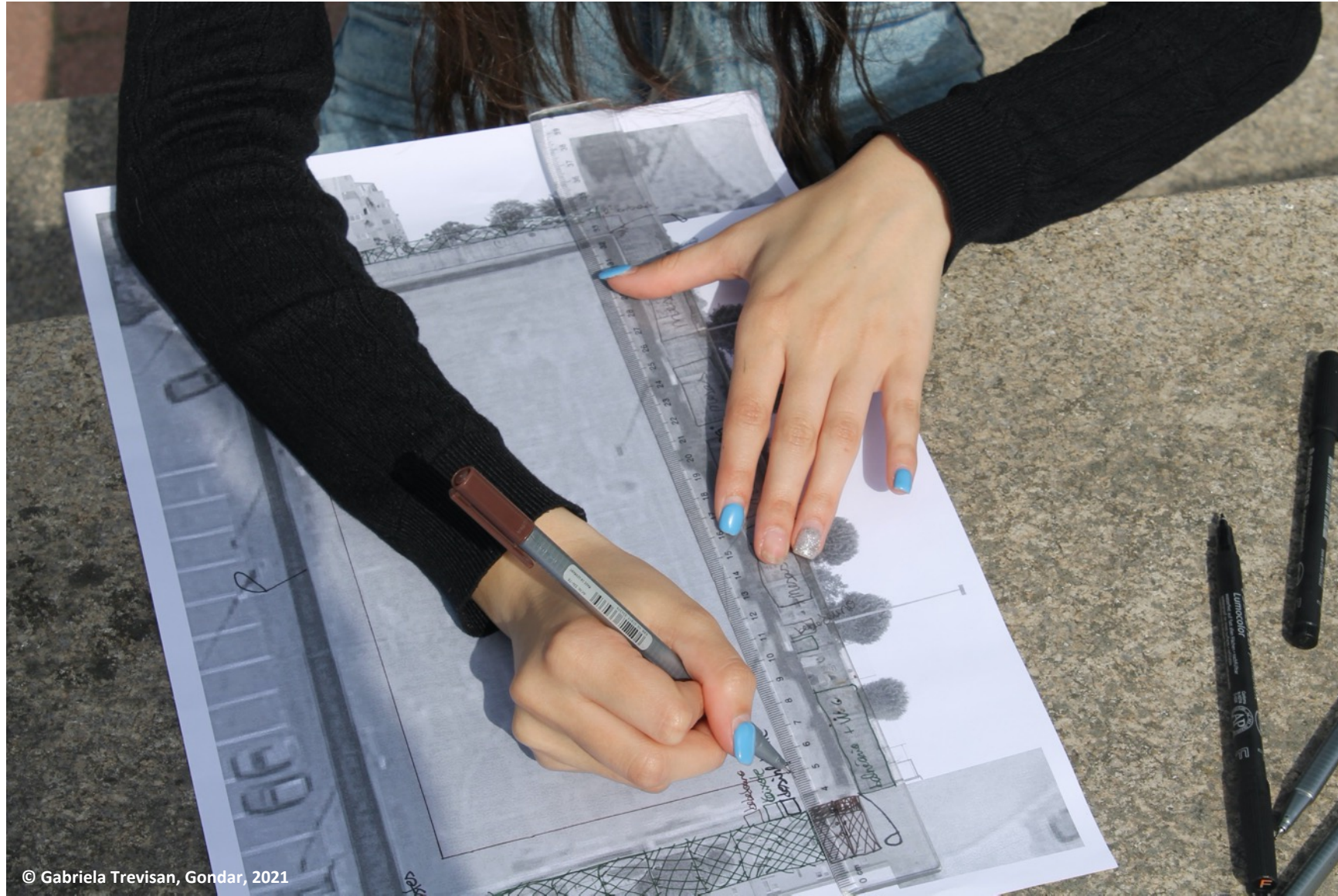

“Sem muros nem fronteiras”: Territory Mapping and transformation with children

Imagino este Lugar | I imagine this place | Bairro da Emboladura | April to July 2021

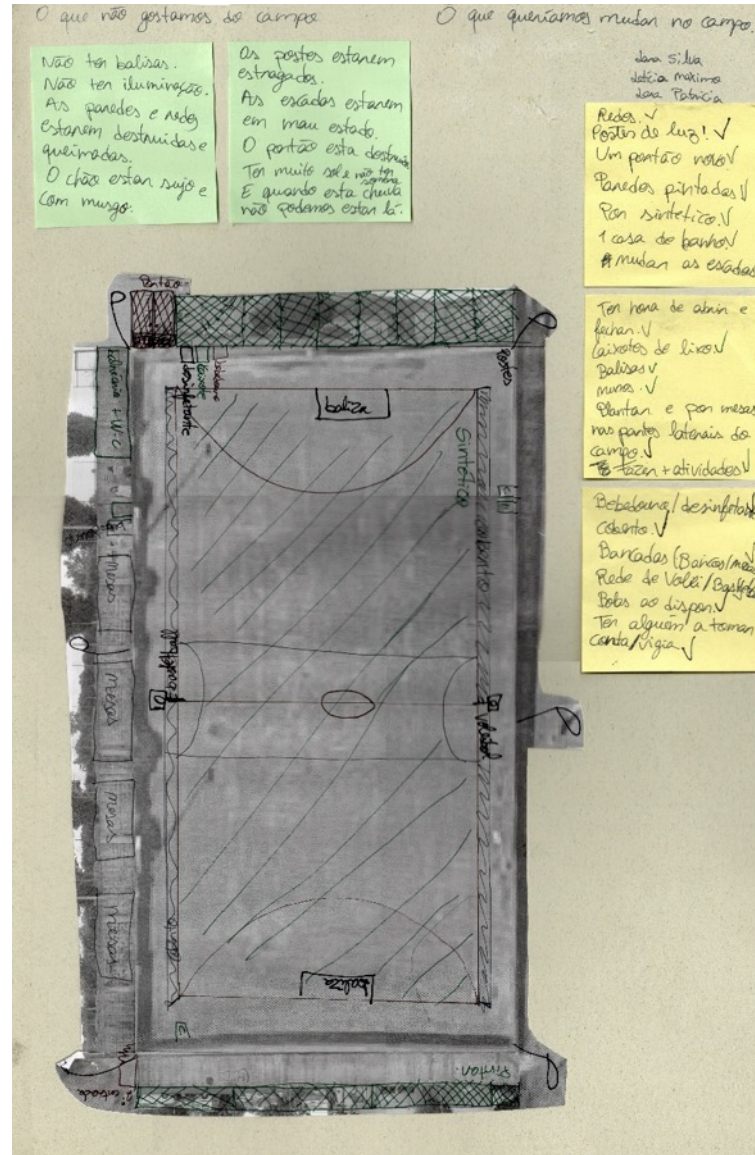

“Sem muros nem fronteiras”: Territory Mapping and transformation with children

Imagino este Lugar | I imagine this place | Bairro da Emboladoura | April to July 2021



o que não gosto

Tubo

o que gostaria de mudar

colocar o campo (não cobrir)
Cestos do basquet
Bancadas dos jogadores

+

Quitar o chão
Reformar o chão
Reformar os grades e o portão
e os grades
Tubo as bancadas
Luminárias



Que para jogar
com os amigos

Da para
meter o telametal

que da para jogar a
bola
velado - é grande

Lara

Eu não gosto
que ~~tenha~~ o campo
não tem balizas
Ruim

O campo todo
porque ele já
tem muitos anos
para mim era
tudo também o campo
esta partido.

melhorar as linhas
e que fique bonito
Ruim

de longe dos lados e por
mas melhor um pouco
sintético

é que tinha das
as balizas no campo

antes das redes
podíamos fazer paredes
e cobrir por cima

mas tinha que
fazer a parte
do branco

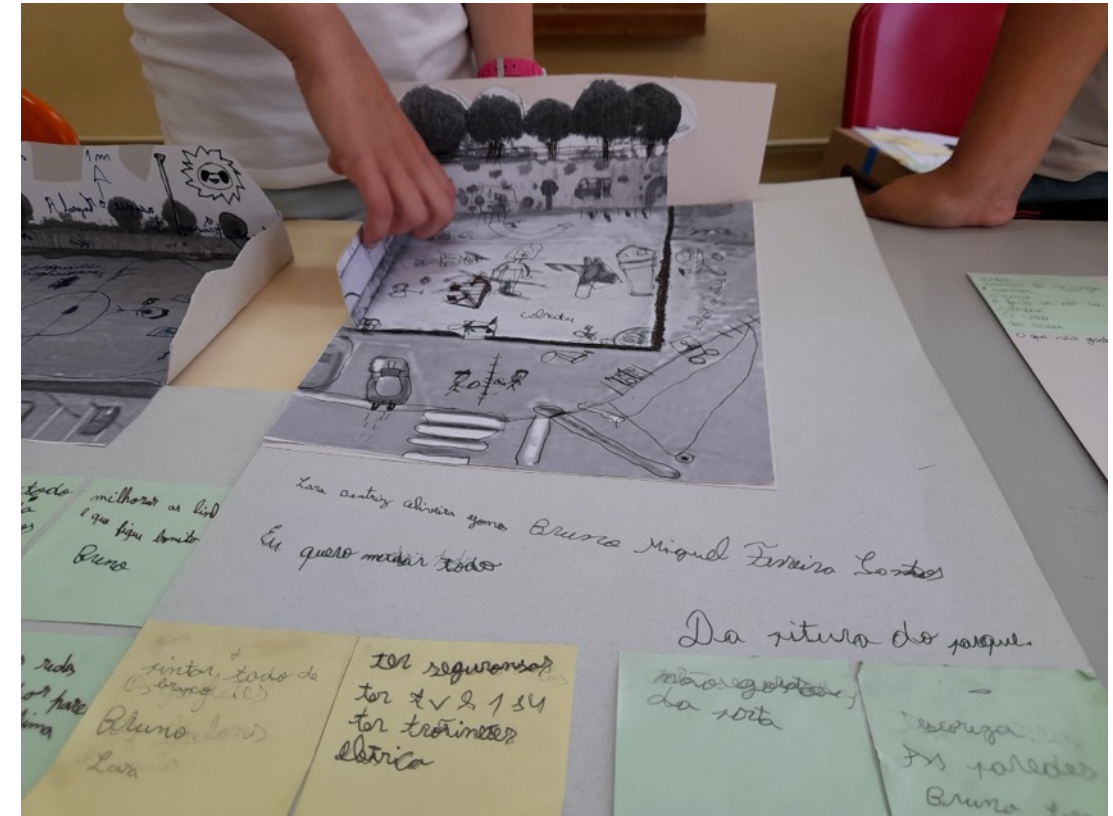

- “For children, the right to the city is the condition of their own citizenship. This does not constitute a legal proclamation nor is it a granted statute. It is, moreover, something that results directly from public policies for children and for the city, which guarantee the participation of children and adults in the construction of the urban territory according to logics of inclusion and sustainability” (Sarmiento, 2019, p. 16)

“Sem muros nem fronteiras”: Territory Mapping and transformation with children

Imagino este Lugar | I imagine this place | Bairro da Emboladoura | July 2021

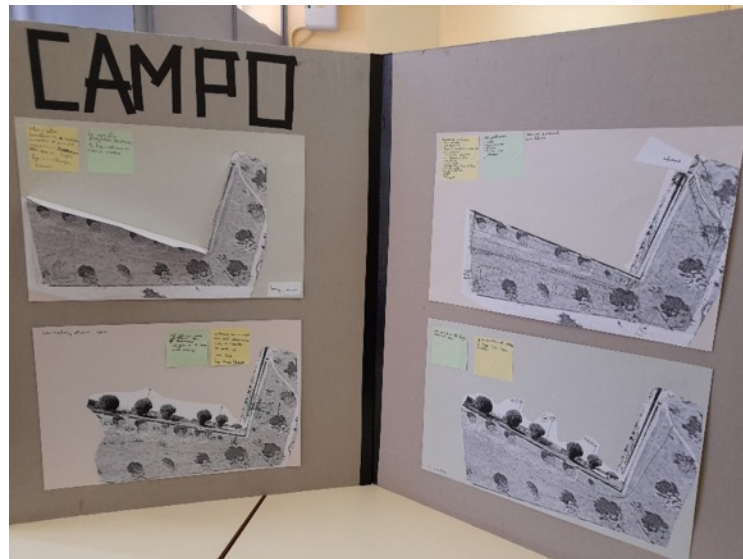
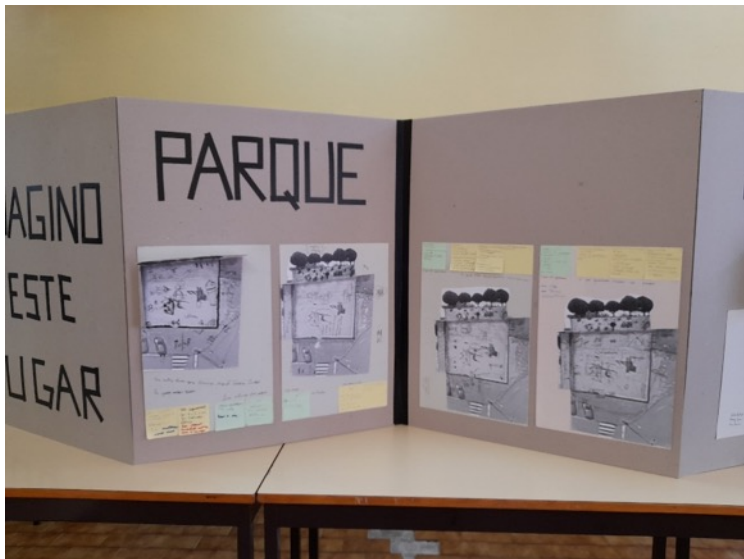
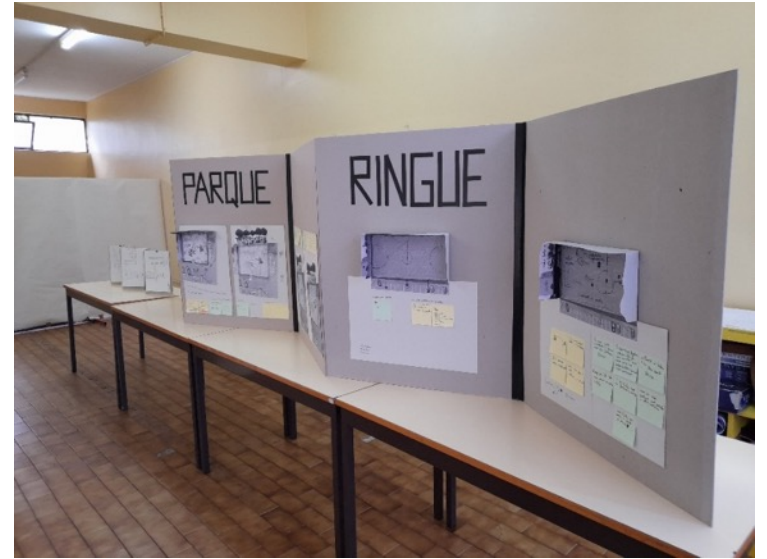

“Sem muros nem fronteiras”: Territory Mapping and transformation with children

Imagino este Lugar | I imagine this place | Bairro da Emboladoura | July 2021



What about real transformation with children and the community?

Survey to the residents of Bairro de Gondar

Queridos moradores da Urbanização da Embaladeira, somos um grupo de crianças e jovens que, com o apoio do projeto Porta 7. Fraternidade, do Prochild Colab, da junta de Freguesia e da Associação de Moradores de Gondar, começamos a pensar e a desenhar o que gostaríamos de criar com o bairro onde vivemos.

Podem ajudar-nos?
Precisamos da vossa ajuda para repartir a estas perguntas que vamos deixar na sua caixa de correio. Depois de responderem podem colar esta folha na caixa de correio da junta da Freguesia até quinta-feira, dia 12 de Novembro, 2020.

Lara
Telente
Lara Silva
Rodrigo
Francisca
Filipe PEREIRA

Sabemos que os edifícios do Bairro têm muitos problemas e que infelizmente ainda ninguém resolve. Essa situação nos depara com nós, mas estamos a tentar contribuir para a melhoria da vida de todos no bairro.

Perguntas:

1) que mais gosto no espaço exterior do bairro?
Gostava de ver florir árvores brancas e vermelhas...
Ver as meu boneco bonito;
Crianças, jovens e velhos!...

2) que é que me faz falta no bairro relativamente ao espaço exterior?
Gostava de ver cumprir as promessas dum pedreiro
Que lá não querem fazer
Nossos hábitos e costumes!?

3) que gostaria de melhorar no espaço exterior do meu bairro?
Gostava que não tivesse assim tanta sujidade...
E quem deve de fazer para não que é resolve-lo!?

4) que é que faz falta no espaço exterior do meu bairro?
Gostava de ver por perto
Quem juntos nos quer manter
Depois de saber as coisas
Que jamais se não fazer!

Se eu pudesse construir uma coisa no meu bairro eu queria:

- churrasqueira comunitária
- esplanada comunitária
- espaço para brincar
- espaço para formação/estudo para crianças e jovens
- espaço para oficinas educativas
- espaço para ensaios
- espaço de lazer/caminho abrigado da chuva/sol
- espaço que possa ser utilizado para várias atividades como: festas, caminões, encontros
- espaço para atividades desportivas
- espaço para iniciativas culturais
- lavandaria / secagem de roupa
- parque bicicletas
- arrumos/arrendações
- paragem de autocarro
- ou então? Alguns brinquedos e respeito
Aqueles que tem direitos!

M.A.

Survey to the residentes of Bairro de Gondar

What do we need in the exterior space of my neighbourhood?

Fewer holes in the pavement and a bicycle enclosure

park to play

Covered bus stops

Grill

Larger space for study and activities

Space for adults

Better conditions in banks, with roof

Park to play

Covered bus stop

Improve pavement

Spaces for adults

What I would like to improve in my neighbourhood?

Parking

Children's playground, soccer field, parks for socializing

Improve children's playground

Buildings, park, countryside, leisure spaces

Apartments, pollution and public spaces

Having ground in the park, not sand

Playground

Soccer field

Public/leisure space

Parking

Pollution

Survey to the residents of Bairro de Gondar

If I could choose...

1st (40) Leisure/living space sheltered from the rain/sun

2nd (37) Bus stop

3rd (36) Space for sports activities

4th (33) Play space

5th (31) Laundry / clothes drying

6th (30) Study/training space for children and young people

6th (30) Space for cultural initiatives

7th (28) Community Barbecue Grills

7th (28) Space for creative workshops

7th (28) Space that can be used for various activities such as: parties, gatherings, meetings

8th (27) Bicycle Park

9th (26) Space for rehearsals

10th (25) Storage

11th (21) Community kitchen

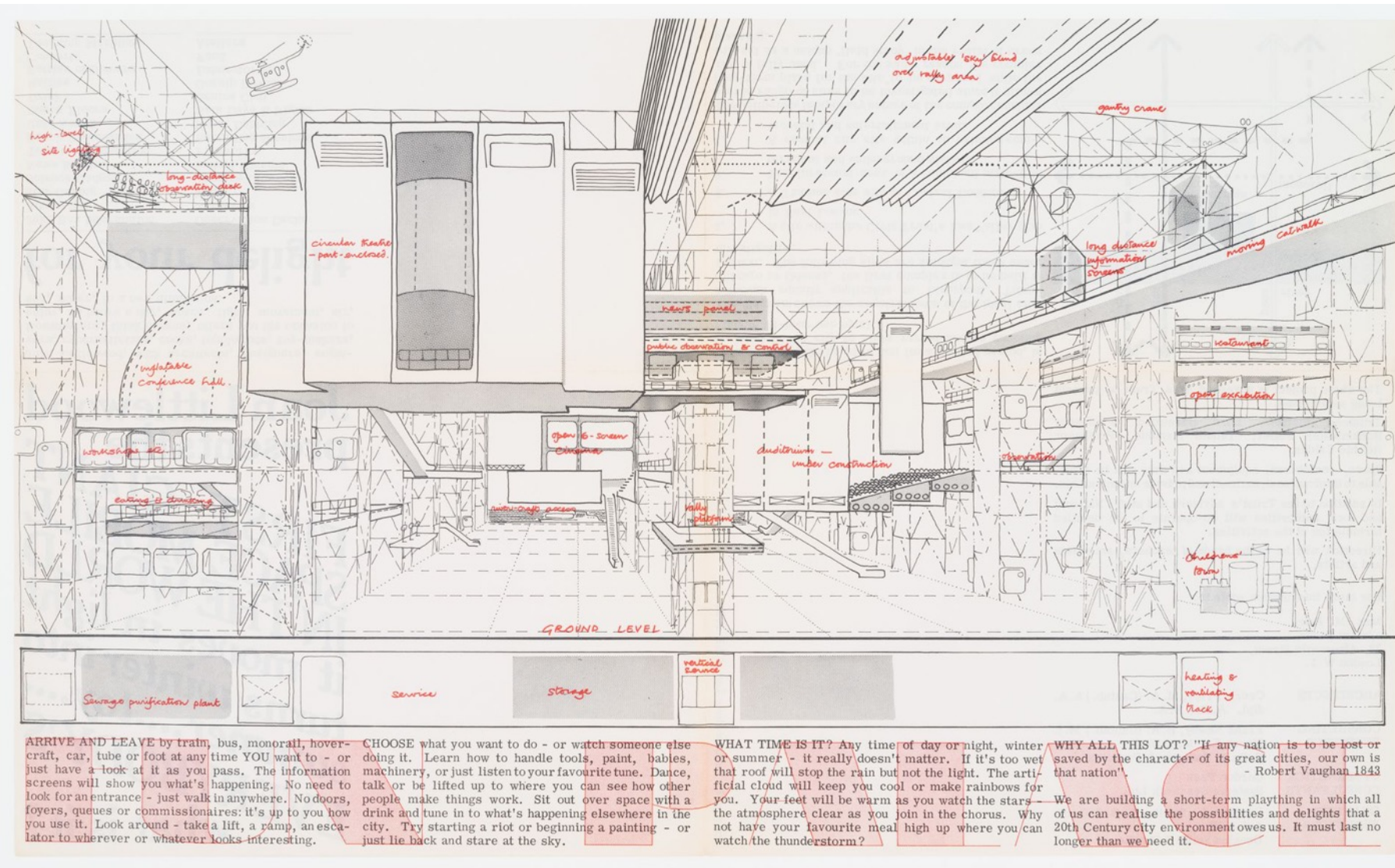

Fun Palace, 1964
A brochure by Cedric Price and Joan Littlewood

Main goal and justification

Respond to the needs identified by residents and institutions in the neighborhood in the preliminary diagnosis, filling the absence of collective public spaces, namely covered spaces that can house different groups and host various activities that promote healthier lives, through the co-construction of the Palácio da Imagem (Imagination Palace), as a multifunctional community space.

Methodology (4 verbs-actions that achieve the objectives of the IP)

interdialogue (the space between the “I” and the “other”);

inhabit (my neighborhood, play, study, food, health, fabric);

recreate (the study, the wall, the floor, the ceiling, the dialogue),

activate (universal prevention, well-being, exchange, the environment, the sky), **materialized in the inter-action of the “Me” in the “We”**

PALÁCIO DA IMAGINAÇÃO

email: palacio.imaginacao@fraterna.org

ENTIDADE PROMOTORA

Fraterna Centro Comunitário de Solidariedade e Integração Social

ENTIDADES PARCEIRAS

Câmara Municipal de Guimarães

Universidade do Minho LAB2PT/EAAD/UM

ProChild CoLab Against Poverty and Social Exclusion – Association

Junta de Freguesia de Gondar

Associação de Moradores da Emboladoura

Unidade de Saúde Familiar de Pevidém

PROGRAMA PÚBLICO

Bairros Saudáveis

FINANCIAMENTO

Fundo Ambiental

República Portuguesa

COORDENAÇÃO

Sofia Machado (Fraterna)

COORDENAÇÃO CIENTÍFICA

Cidália F. Silva (EAAD.Lab2PT/UM)

Gabriela Trevisan (ProChild CoLab)

GESTÃO FINANCEIRA

Adelina Alves (Fraterna)

Paulo Castelar (Fraterna)

PROJETO DE ARQUITETURA

Cidália F. Silva (EAAD.Lab2PT/UM) - Coordenadora do Projeto

Débora Moura (EAAD.Lab2PT/UM)

Diana Gouveia (EAAD.Lab2PT/UM / Fraterna)

Mariana Carvalho (ProChild CoLab)

Gabriela Trevisan (ProChild CoLab)

Desenvolvimento do projeto com comunidade do Bairro

COMUNICAÇÃO

Sofia Machado (Fraterna)

Ana Martins (Fraterna)

Diana Gouveia (EAAD.Lab2PT/UM / Fraterna)

Débora Moura (EAAD.Lab2PT/UM)

DESIGN E ILUSTRAÇÃO

Alexandra Ribeiro (ProChild CoLab)

Mariana Carvalho (ProChild CoLab)

Crianças do Bairro da Emboladoura

BRINCÁRIO

Crianças do Bairro da Emboladoura

Equipa do Projeto

OUTROS APOIOS

Arcol Cash & Carry

Empresa Vaz da Costa

Fornecedora Outeiro

Laboratório da Paisagem

Dr. Joaquim António da Costa Borges (Médico psiquiatra)

Dra.ª Georgina Monteiro (Médica pediatra)

LOCALIZAÇÃO

Bairro da Emboladoura, Guimarães

Construction of the image for the logo
By: Lara, Rodrigo, Rodrigo, Filipe, Celeste, Gabriela



Cubes of Imagination
By: Lara, Rodrigo, Rodrigo, Filipe, Celeste, Gabriela

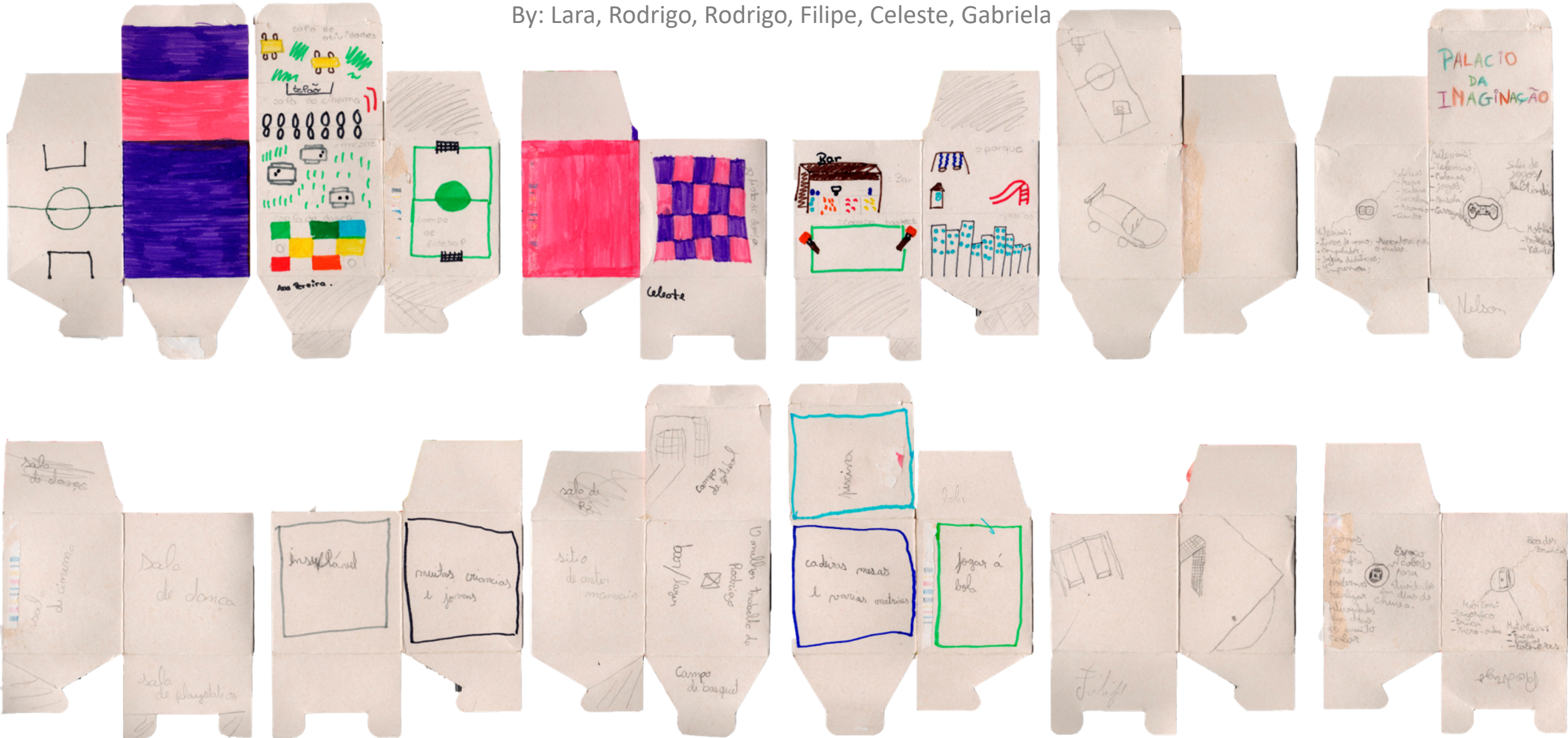

Construction of the image for the logo
By: Lara, Rodrigo, Rodrigo, Filipe, Celeste, Gabriela



Logo

By: Alexandra Ribeiro, ProChild CoLAB





Activities

interdialogue

recreate the study
recreate the wall
recreate the floor
recreate the ceiling
recreate the dialog

Inhabit my Neighborhood

Inhabiting Playing
inhabit the study
inhabit the food
Inhabit family health
Inhabit mental health
inhabit the fabric

Activate universal prevention

activate wellness
activate exchange
activate environment
activate the sky

Palace of Imagination

Activities

Recreate study

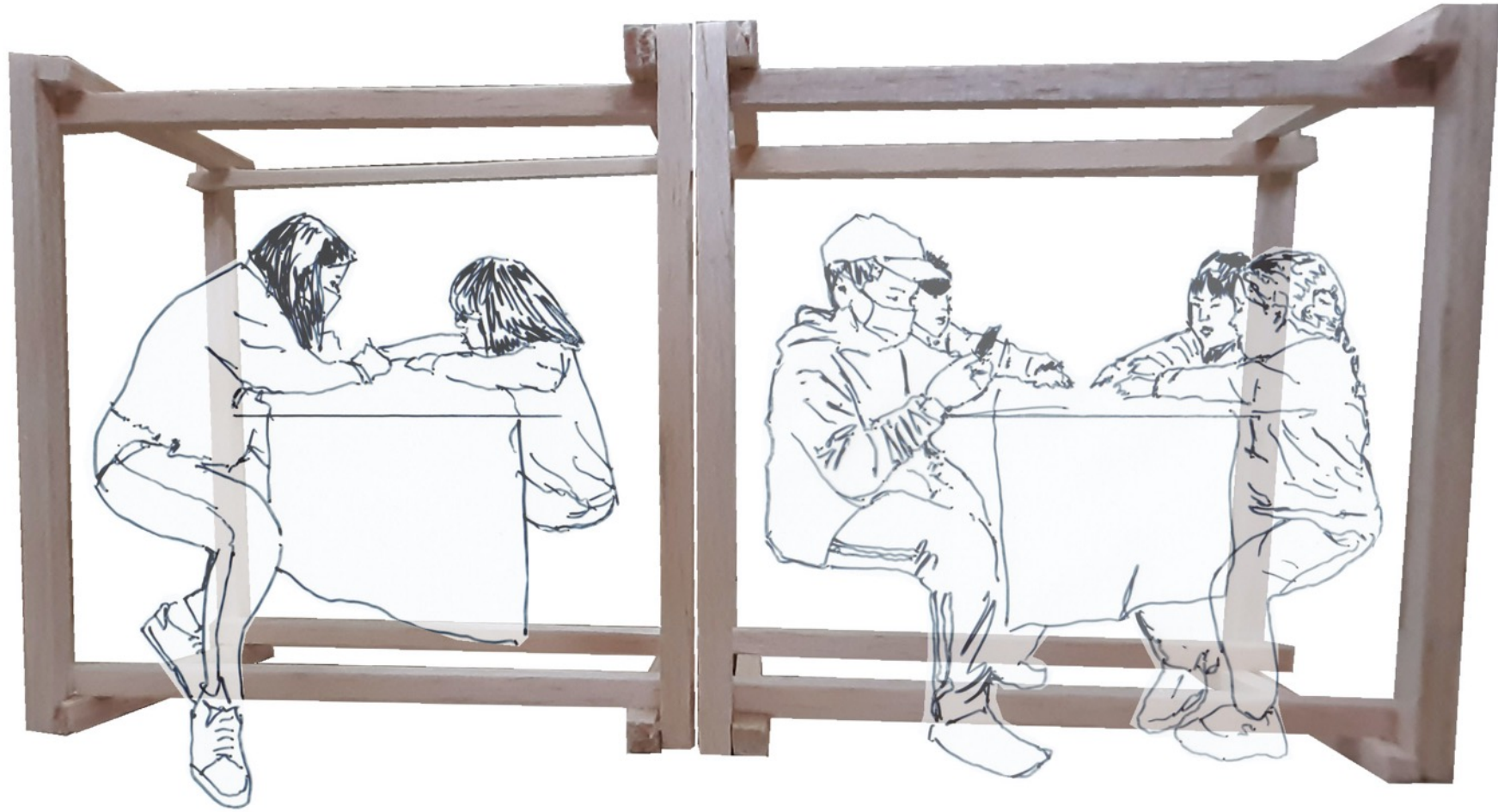

Activities

Recreate study

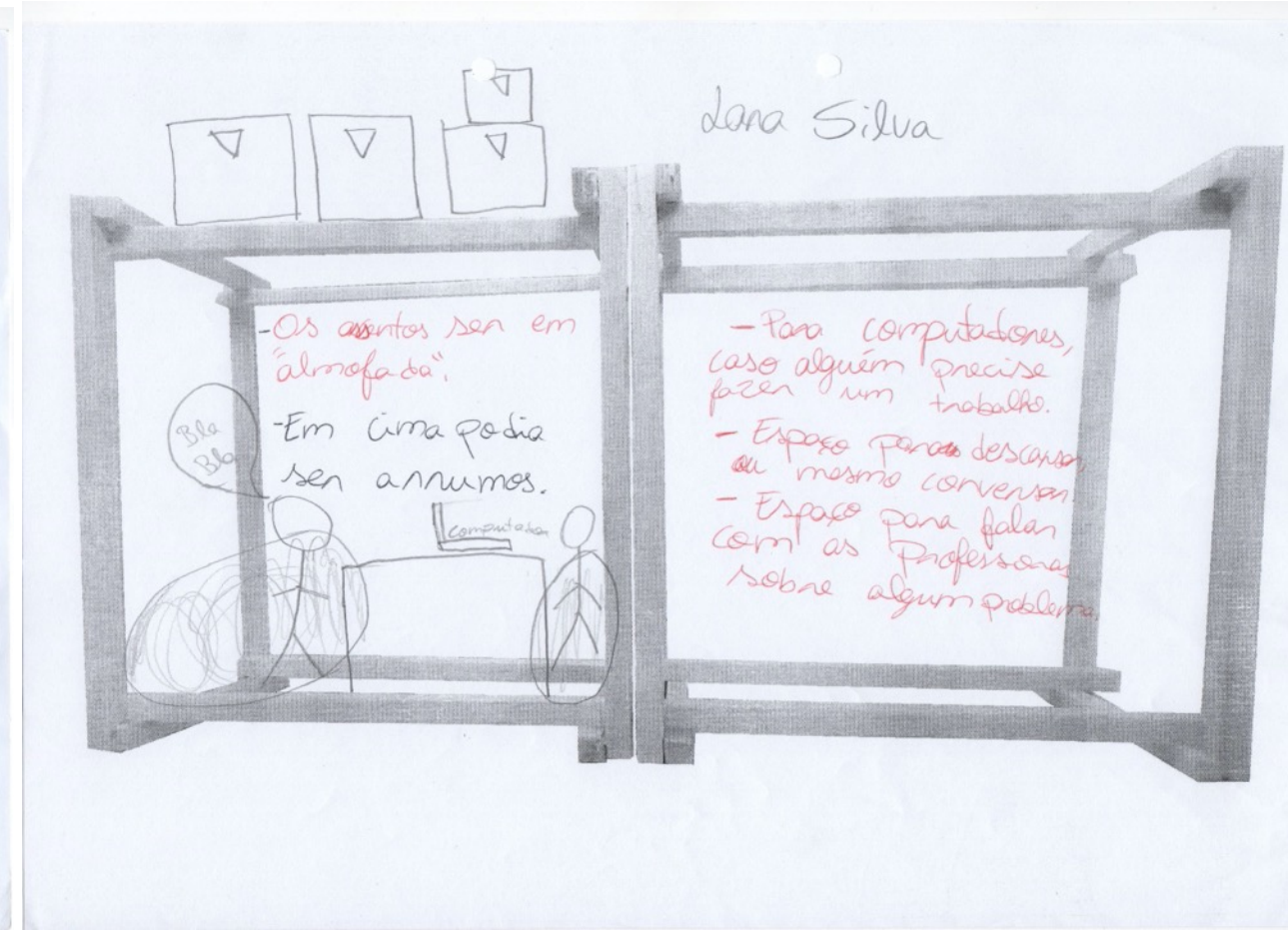
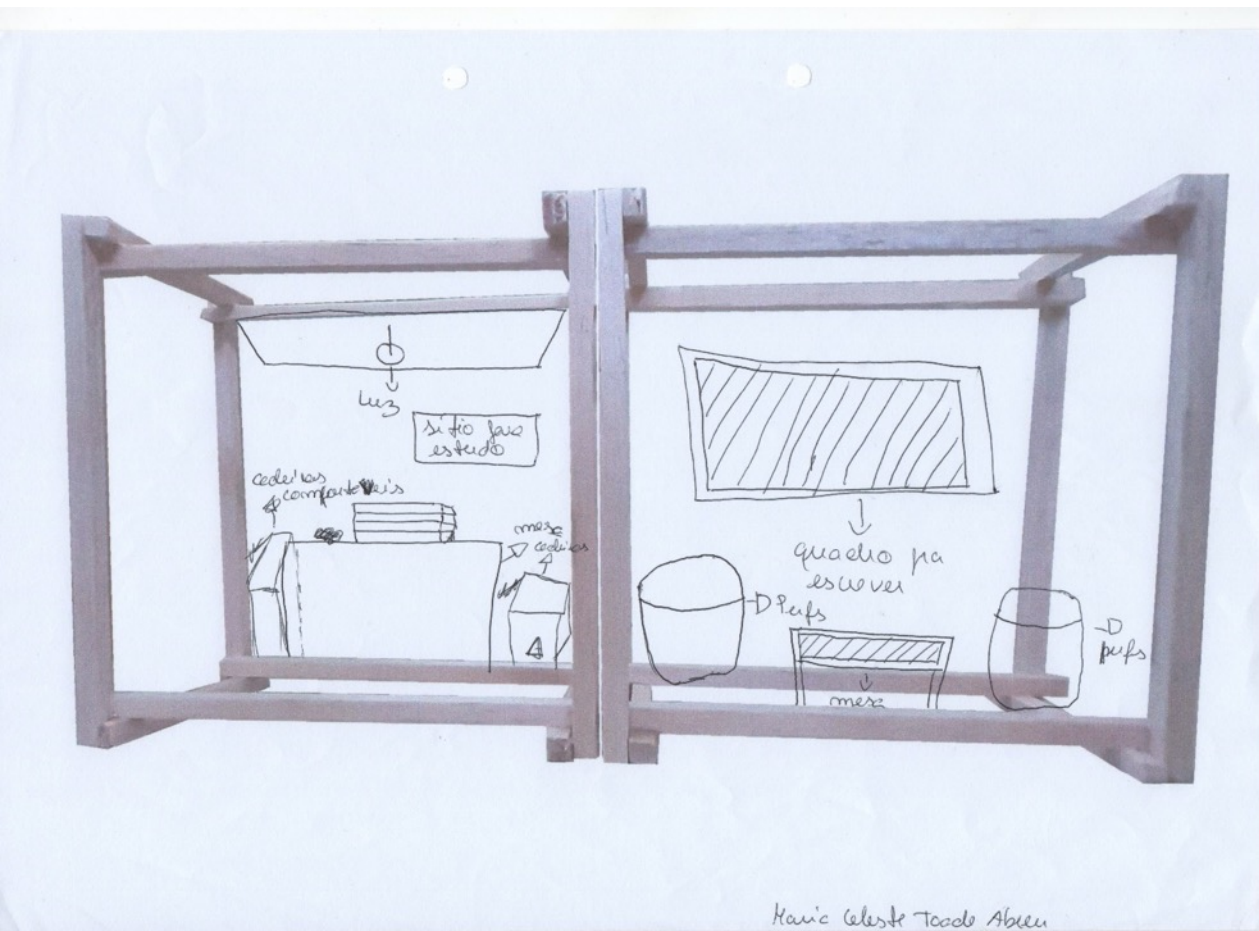

Activities

Recreate study

Program proposals for a study Box made by children and young people

March 2022

To play

- space for board games
- space to play

To look/listen

- space to listen to music
- space for film projection

To study / work

- space to study
- tables with light
- space with whiteboard to write

To be / to talk / to rest

- space to chat
- comfortable space
- space with comfortable seats (with cushions)
- space to rest (poufs)
- space with a hammock (must have an appointment time)
- space to talk to the teachers about a problem (suggestion from the elders)

To read

- space for a library
- space with open boxes with books

To empower

- space with available equipment: computer, camera, ...

Palace of Imagination

Activities

Recreate study

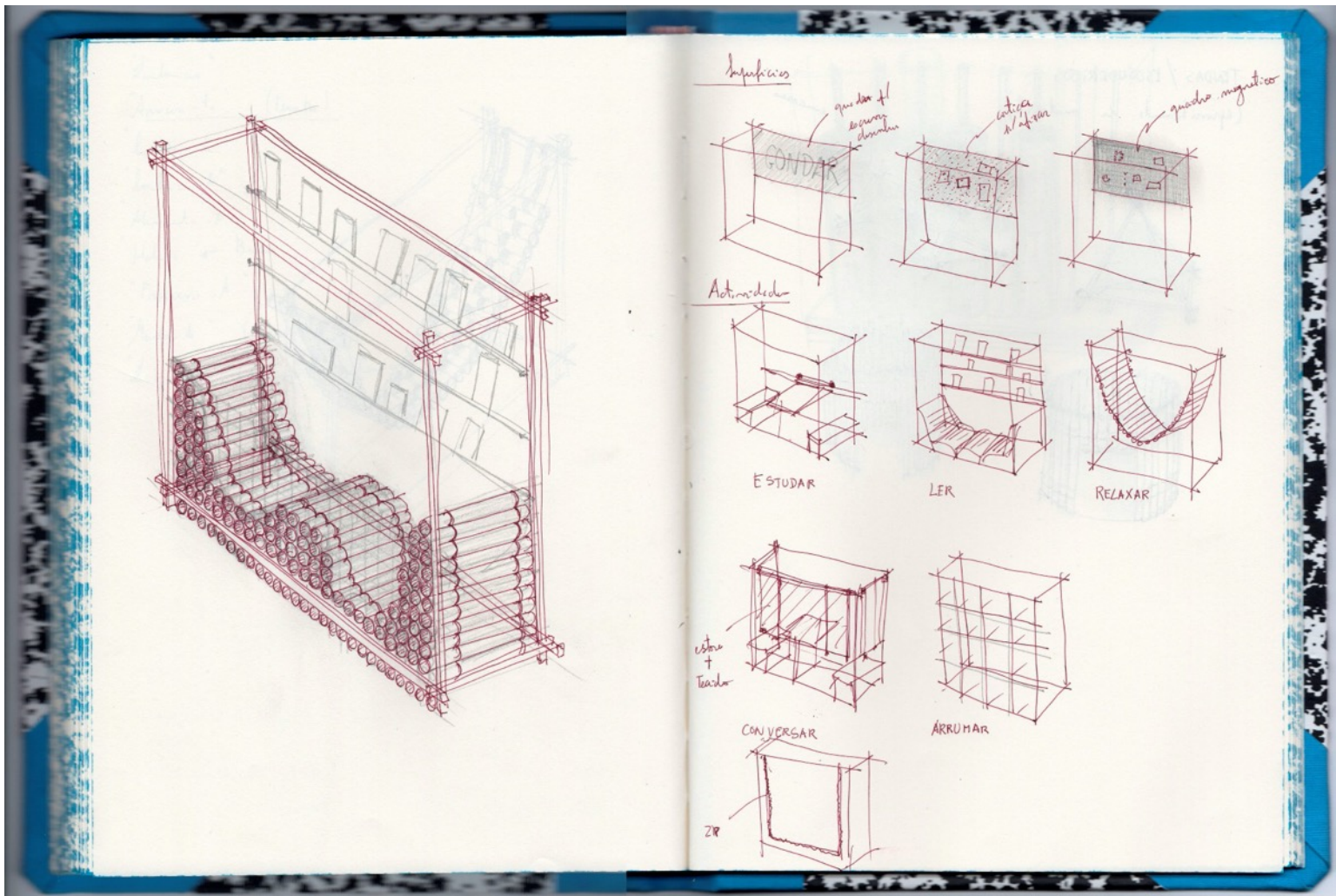

Activities

Recreate study



Activities

Recreate study



Activities

Recreate study



Activities

Recreate study

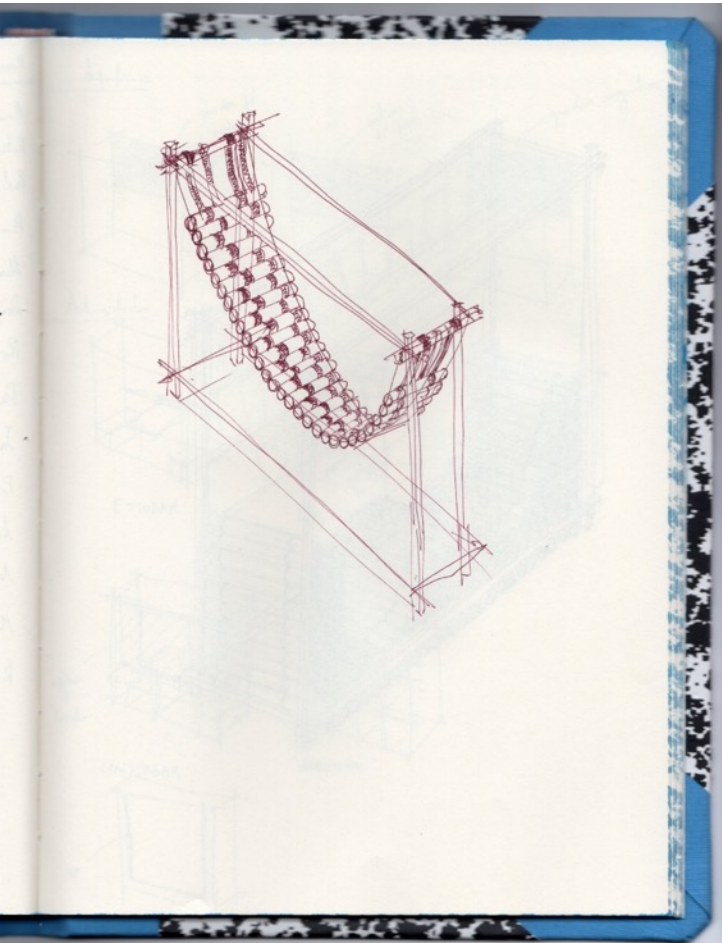

Activities

Recreate study



Activities

Recreate study



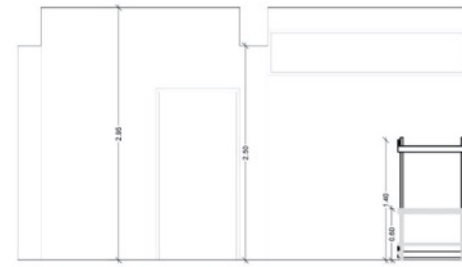

Corte A

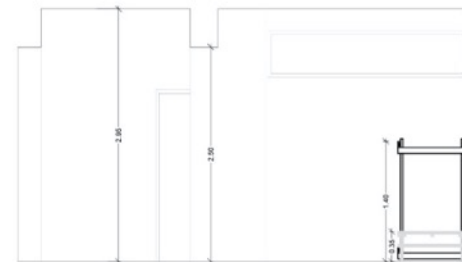

Corte B

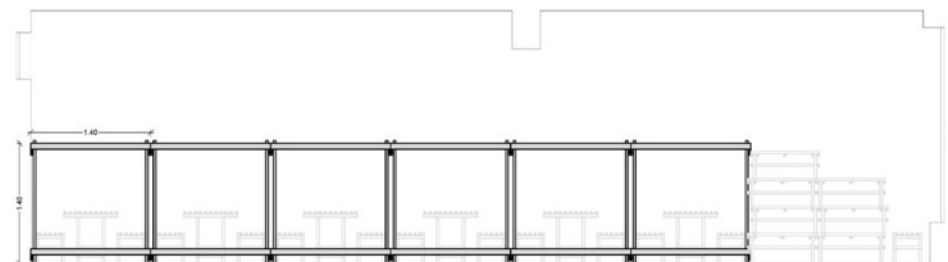

Corte C

1102-10-01/2022 Nº 2022/22 - 2.ª FASE - PROJETO DE EXECUÇÃO - D.A. Nº 11/2022, de 4 de Maio, do artigo 3.º do Regulamento Geral do Sistema Nacional de Avaliação da Qualidade da Educação (SINAPE) e do artigo 5.º do Regulamento Geral do Sistema Nacional de Avaliação da Qualidade da Educação (SINAPE).

PALÁCIO DA IMAGINAÇÃO

email: palacio.imagnacao@fratema.org

ENTIDADE PROMOTORA

Fratema Centro Comunitário de Solidariedade e Integração Social

ENTIDADES PARCEIRAS

Câmara Municipal de Guimarães
Universidade do Minho LAB2PT/EAAD/UM
ProChild CoLab Against Poverty and Social Exclusion - Association
Junta de Freguesia de Gondar
Associação de Moradores da Emboladoura
Unidade de Saúde Familiar de Pevidém

PROGRAMA PÚBLICO

Bairros Saudáveis

FINANCIAMENTO

Fundo Ambiental
República Portuguesa

COORDENAÇÃO

Sofia Machado (Fratema)

COORDENAÇÃO CIENTÍFICA

Cidália F. Silva (EAAD.Lab2PT/UM)
Gabriela Trevisan (ProChild CoLab)

GESTÃO FINANCEIRA

Adelina Alves (Fratema)
Paulo Castelar (Fratema)

PROJETO DE ARQUITETURA

Cidália F. Silva (EAAD.Lab2PT/UM) - Coordenadora do Projeto
Débora Moura (EAAD.Lab2PT/UM)
Diana Gouveia (EAAD.Lab2PT/UM / Fratema)
Mariana Carvalho (ProChild CoLab)
Gabriela Trevisan (ProChild CoLab)
Desenvolvimento do projeto com comunidade do Bairro

COMUNICAÇÃO

Sofia Machado (Fratema)
Ana Martins (Fratema)
Diana Gouveia (EAAD.Lab2PT/UM / Fratema)
Débora Moura (EAAD.Lab2PT/UM)

DESIGN E ILUSTRAÇÃO

Alexandra Ribeiro (ProChild CoLab)
Mariana Carvalho (ProChild CoLab)
Crianças do Bairro da Emboladoura

BRINÇÁRIO

Crianças do Bairro da Emboladoura
Equipa do Projeto

OUTROS APOIOS

Arco! Cash & Carry
Empresa Vaz da Costa
Fornecedora Outeiro
Laboratório da Paisagem
Dr. Joaquim António da Costa Borges (Médico psiquiatra)
Dra.ª Georgina Monteiro (Médica pediatra)

LOCALIZAÇÃO

Bairro da Emboladoura, Guimarães

DATA

Julho 2022

REF.

Página 2

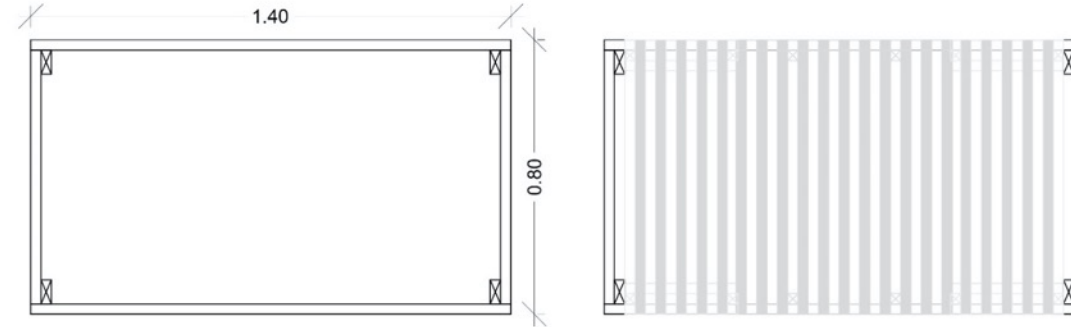

Planta | O Módulo da Box + Mesa + Banco

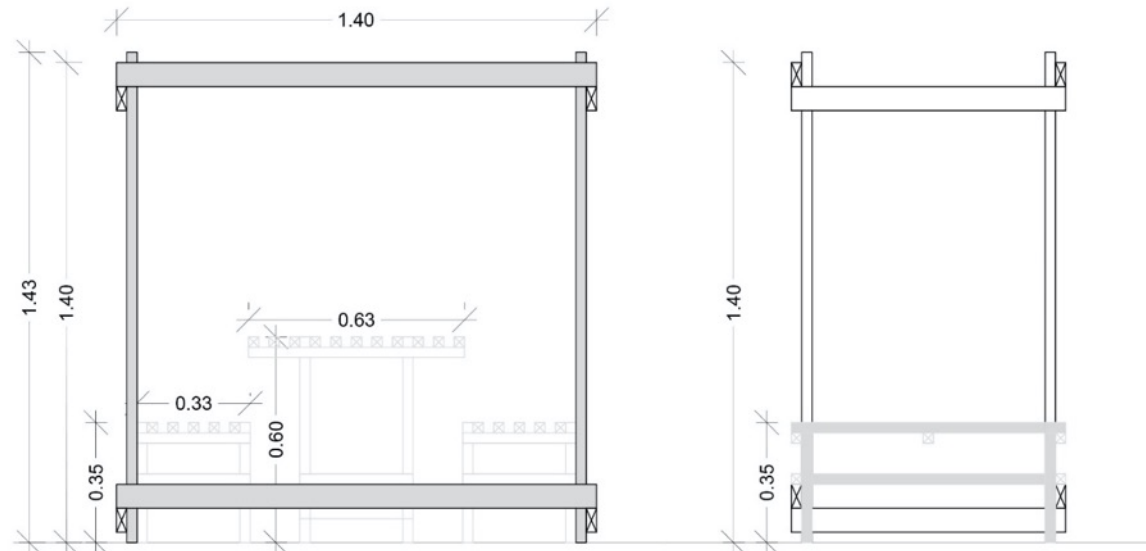

Corte | O Módulo da Box + Mesa + Banco

PALÁCIO DA IMAGINAÇÃO

email: palacio.imaginacao@fraterna.org

ENTIDADE PROMOTORA

Fraterna Centro Comunitário de Solidariedade e Integração Social

ENTIDADES PARCEIRAS

Câmara Municipal de Guimarães
Universidade do Minho LAB2PT/EAAD/UM
ProChild CoLab Against Poverty and Social Exclusion - Association
Junta de Freguesia de Gondar
Associação de Moradores da Emboladoura
Unidade de Saúde Familiar de Pevidém

PROGRAMA PÚBLICO

Bairros Saudáveis

FINANCIAMENTO

Fundo Ambiental
República Portuguesa

COORDENAÇÃO

Sofia Machado (Fraterna)

COORDENAÇÃO CIENTÍFICA

Cidália F. Silva (EAAD.Lab2PT/UM)
Gabriela Trevisan (ProChild CoLab)

GESTÃO FINANCEIRA

Adelina Alves (Fraterna)
Paulo Castelar (Fraterna)

PROJETO DE ARQUITETURA

Cidália F. Silva (EAAD.Lab2PT/UM) - Coordenadora do Projeto
Débora Moura (EAAD.Lab2PT/UM)
Diana Gouveia (EAAD.Lab2PT/UM / Fraterna)
Mariana Carvalho (ProChild CoLab)
Gabriela Trevisan (ProChild CoLab)
Desenvolvimento do projeto com comunidade do Bairro

COMUNICAÇÃO

Sofia Machado (Fraterna)
Ana Martins (Fraterna)
Diana Gouveia (EAAD.Lab2PT/UM / Fraterna)
Débora Moura (EAAD.Lab2PT/UM)

DESIGN E ILUSTRAÇÃO

Alexandra Ribeiro (ProChild CoLab)
Mariana Carvalho (ProChild CoLab)
Crianças do Bairro da Emboladoura

BRINCÁRIO

Crianças do Bairro da Emboladoura
Equipa do Projeto

OUTROS APOIOS

Arco Cash & Carry
Empresa Vaz da Costa
Fornecedora Outeiro
Laboratório da Paisagem
Dr. Joaquim António da Costa Borges (Médico psiquiatra)
Dra.ª Georgina Monteiro (Médica pediatra)

LOCALIZAÇÃO

Bairro da Emboladoura, Guimarães

DATA

Julho 2022

REF.

Página 3

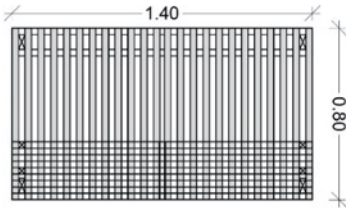
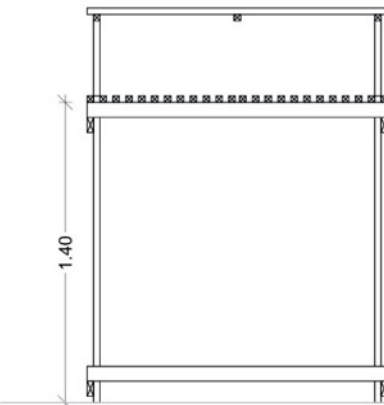
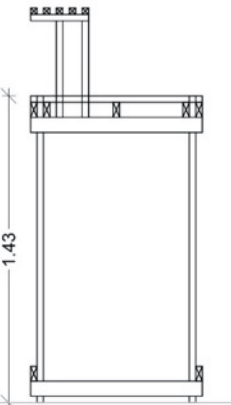
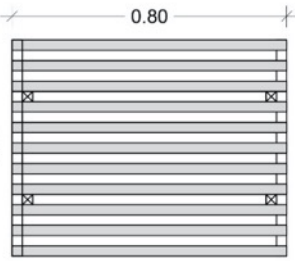
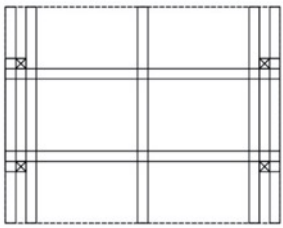
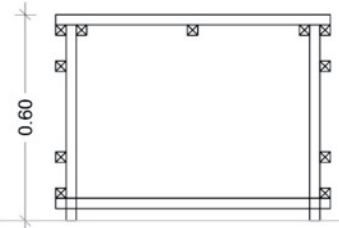
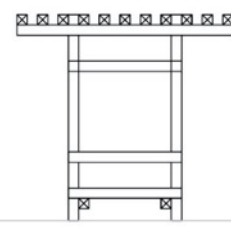
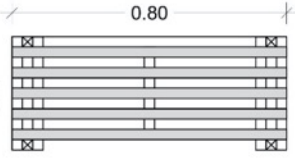
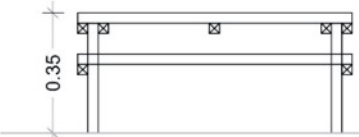
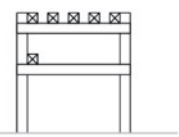

 <p>6x Módulo</p>	 
    <p>5x Mesa</p>	
   <p>19x Banco</p>	
<p>PALÁCIO DA IMAGINAÇÃO email: palacio.imaginacao@fraterna.org</p> <p>ENTIDADE PROMOTORA Fraterna Centro Comunitário de Solidariedade e Integração Social</p> <p>ENTIDADES PARCEIRAS Câmara Municipal de Guimarães Universidade do Minho LAB2PT/EAAD/UM ProChild CoLab Against Poverty and Social Exclusion – Association Junta de Freguesia de Gondar Associação de Moradores da Emboladoura Unidade de Saúde Familiar de Pevidém</p> <p>PROGRAMA PÚBLICO Bairros Saudáveis</p> <p>FINANCIAMENTO Fundo Ambiental República Portuguesa</p> <p>COORDENAÇÃO Sofia Machado (Fraterna)</p> <p>COORDENAÇÃO CIENTÍFICA Cidália F. Silva (EAAD.Lab2PT/UM) Gabriela Trevisan (ProChild CoLab)</p> <p>GESTÃO FINANCEIRA Adelina Alves (Fraterna) Paulo Castelar (Fraterna)</p> <p>PROJETO DE ARQUITETURA Cidália F. Silva (EAAD.Lab2PT/UM) - Coordenadora do Projeto Débora Moura (EAAD.Lab2PT/UM) Diana Gouveia (EAAD.Lab2PT/UM / Fraterna) Mariana Carvalho (ProChild CoLab) Gabriela Trevisan (ProChild CoLab) Desenvolvimento do projeto com comunidade do Bairro</p> <p>COMUNICAÇÃO Sofia Machado (Fraterna) Ana Martins (Fraterna) Diana Gouveia (EAAD.Lab2PT/UM / Fraterna) Débora Moura (EAAD.Lab2PT/UM)</p> <p>DESIGN E ILUSTRAÇÃO Alexandra Ribeiro (ProChild CoLab) Mariana Carvalho (ProChild CoLab) Crianças do Bairro da Emboladoura</p> <p>BRINCÁRIO Crianças do Bairro da Emboladoura Equipa do Projeto</p> <p>OUTROS APOIOS Arcof Cash & Carry Empresa Vaz da Costa Fornecedora Outeiro Laboratório da Paisagem Dr. Joaquim António da Costa Borges (Médico pediatra) Dra.ª Georgina Monteiro (Médica pediatra)</p> <p>LOCALIZAÇÃO Bairro da Emboladoura, Guimarães</p> <p>DATA Julho 2022</p> <p>REF. Página 4</p>	

REVISÃO Nº 002 DE 2022 DE 2022/07/20 - PROPOSTA DE PROJETO DE ARQUITETURA
Lugar: Rua da Emboladoura, 10 - 4830-105 Guimarães, Portugal
O presente projeto é propriedade intelectual da Fraterna Associação para o Desenvolvimento Social, Lda e não pode ser reproduzido sem a autorização da Fraterna Associação para o Desenvolvimento Social, Lda.

Activities

Recreate study

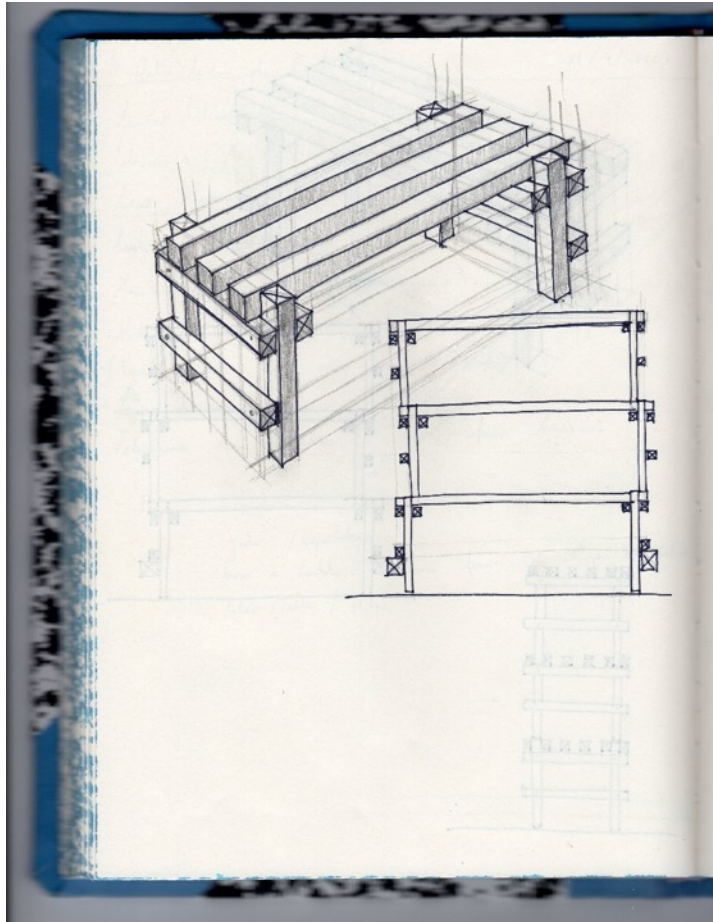

Activities

Recreate study



Activities

Inhabit Play

(Video financed by DAAD e SRH University Heidelberg)



Website:

<https://www.facebook.com/projetopalaciodaimaginacao>

<https://www.facebook.com/PalacioImaginacao/>

<https://www.instagram.com/palaciodaimaginacao/>

Vielen Dank für eure Hilfe bei unserem Schloss der Phantasie

cidalia@arquitetura.uminho.pt

gabriela.trevisan@prochildcolab.pt

mariana.carvalho@prochildcolab.pt

dianagouveiaamaral@gmail.com