

## Generation of Entropy in Spark Ignition Engines

Bernardo Ribeiro, Jorge Martins\*, António Nunes  
Universidade do Minho  
Departamento de Engenharia Mecânica  
4800-058 – Guimarães – PORTUGAL  
jmartins@dem.uminho.pt

### Abstract

Recent engine development has focused mainly on the improvement of engine efficiency and output emissions. The improvements in efficiency are being made by friction reduction, combustion improvement and thermodynamic cycle modification. New technologies such as Variable Valve Timing (VVT) or Variable Compression Ratio (VCR) are important for the latter.

To assess the improvement capability of engine modifications, thermodynamic analysis of indicated cycles of the engines is made using the first and second laws of thermodynamics. The Entropy Generation Minimization (EGM) method proposes the identification of entropy generation sources and the reduction of the entropy generated by those sources as a method to improve the thermodynamic performance of heat engines and other devices. A computer model created and implemented in MATLAB Simulink was used to simulate the conventional Otto cycle and the various processes (combustion, free expansion during exhaust, heat transfer and fluid flow through valves and throttle) were evaluated in terms of the amount of the entropy generated.

An Otto cycle, a Miller cycle (over-expanded cycle) and a Miller cycle with compression ratio adjustment are studied using the referred model in order to evaluate the amount of entropy generated in each cycle. All cycles are compared in terms of work produced per cycle.

*Keywords: IC engines, Miller cycle, entropy generation, over-expanded cycle*

### 1. Introduction

Several technologies are used for the thermodynamic improvement of internal combustion engines, such as VVT (Flierl and Kluting, 2000) or VCR (Drangel et al. (2002). To evaluate the potential for thermodynamic improvement of these and other technologies, numerical studies must be performed using different tools. EGM (Drangel et al., 2002 and Bejan, 1996) is proposed as a tool for internal combustion engine improvement based on the measurement of the entropy generated at several processes taking place with the engine operation. With these results it is possible to define strategies for engine improvement, reducing the amount of entropy generated.

Spark ignition internal combustion engines, running at low loads, have their thermal efficiency reduced due to the effect of the throttle valve that controls the engine load and by the fact that the compression starts at low pressure. Under part load conditions, engines use some of the

work to pump air across the partially closed throttle valve. In the Miller cycle engine the load is controlled by inlet valve timing, eliminating the throttle valve and the subsequent pumping losses (Flierl and Kluting, 2000). A comparison between the Otto and Miller cycles was already presented in a theoretical study (Martins, 2004). In the same study the Miller cycle was presented as an alternative to the conventional Otto cycle engine when used under part load conditions. A significant improvement to the Miller cycle may be achieved if compression ratio adjustment is used in addition to valve timing variation.

The Miller cycle is different from the conventional Otto cycle engine for it has a longer expansion. This longer expansion is achieved using an effective shorter intake stroke. The intake valve, which in the Otto cycle closes shortly after BDC, in the Miller cycle closes a significant time before BDC (early intake valve closure - EIVC), creating a depression inside the cylinder (1-8 of *Figure 1*), or closes significantly after BDC (late intake valve closure - LIVC), expelling the air and fuel mixture back to the intake manifold (5-1 of *Figure 2*). The effect is to

---

\* Author to whom correspondence should be sent

start the compression (point 1 of *Figure 1* and *Figure 2*) after the compression starting point of the Otto cycle, which is near BDC. In fact, in the Miller cycle the intake is always at atmospheric pressure, and work is not used to pump the charge into the cylinder as in the Otto cycle. At the same time, pressure and temperature at the exhaust valve opening are lower, which means that a smaller amount of enthalpy of the exhaust gases is lost during the exhaust process.

It was shown in a previous work (Martins, 2004) that the Miller cycle only with intake valve closure time variation brings some improvement to engine cycle efficiency. However the same cycle with a compression ratio adjustment brings a significant improvement to the thermal efficiency of the theoretical cycle. The compression ratio adjustment is made in order to maintain the same effective compression ratio, just to avoid knock onset. As the intake valve closure is delayed, the effective compression ratio of the engine decreases and the maximum temperature and pressure inside the cylinder decrease, leading to less efficient cycles. This effect should be inverted by increasing the effective compression ratio.

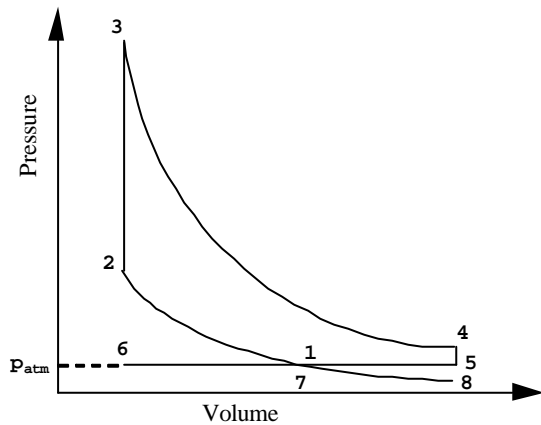

Figure 1. Miller cycle with EIVC.

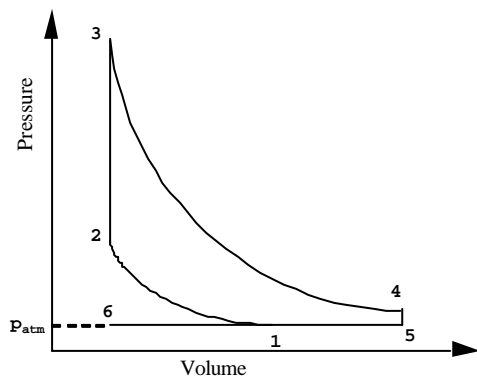

Figure 2. Miller cycle with LIVC.

## 2. Thermodynamic Engine Model

An entropy generation analysis was applied to internal combustion engines and an entropy generation calculation model was developed. A computer model capable of calculating the entropy generation due to several processes within the engine shows that the main entropy generators in an internal combustion engine are the combustion, free expansion of gas during exhaust and intake, heat transfer and fluid flow through valves (including the throttle valve). A scheme of this calculation model is presented in *Figure 3*. This model is divided in a first law of thermodynamic model and an entropy generation model.

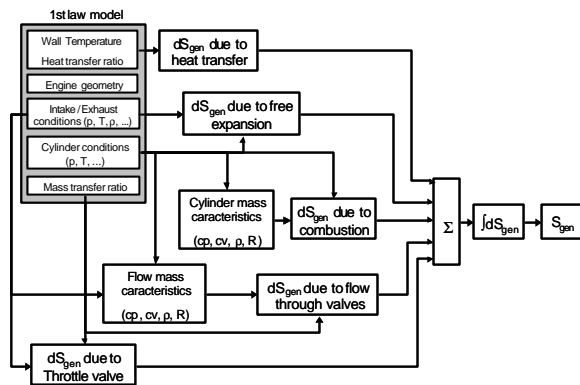

Figure 3. Computer model structure for entropy generation calculation.

A single zone model is based on the first law of thermodynamics expressed as:

$$dU = dQ - dW + h_{in} dm_{in} - h_{out} dm_{out} \quad (1)$$

From (1) temperature can be calculated by the integration of  $\frac{dT}{dt}$ :

$$\begin{aligned} m_{cyl} c_v(T) \frac{dT}{dt} + T c_{v,m}(T) \frac{dm_{cyl}}{dt} &= \\ &= \frac{dQ}{dt} - p \frac{dV}{dt} + \sum T_i c_p(T)_i \frac{dm_i}{dt} \end{aligned} \quad (2)$$

And pressure is calculated from the integration of:

$$\begin{aligned} \frac{dp}{dt} V + p \frac{dV}{dt} &= T \sum_i R_i \frac{dm_i}{dt} + \sum_i R_i m_i \frac{dT}{dt} \Leftrightarrow \\ \Leftrightarrow \frac{dp}{dt} &= \frac{T \sum_i R_i \frac{dm_i}{dt} + \sum_i R_i m_i \frac{dT}{dt} - p \frac{dV}{dt}}{V} \end{aligned} \quad (3)$$

where  $m_{cyl}$  is the mass of working fluid trapped in the cylinder and  $\frac{dm_i}{dt}$  is the flow rate of each species  $i$  through the valves.

In the model, heat from combustion is supplied using a Wiebe function (Heywood, 1988):

$$x_b = 1 - \exp \left[ -a \left( \frac{\theta - \theta_0}{\Delta\theta} \right)^{m+1} \right] \quad (4)$$

With  $a = 5$  and  $m = 2$ ,  $\theta_0$  is the spark time at the beginning of combustion in crank angle and  $\Delta\theta$  is the burning interval in crank angle. The heat release rate is given by:

$$\frac{dQ}{d\theta} = Q_r \frac{dx_b}{d\theta} \quad (5)$$

where:

$$Q_R = \eta_c m_f Q_{LHV} \quad (6)$$

and (Abd Alla, 2002)

$$\eta_c = \eta_{c \max} \left( -1.6082 + 4.6509\lambda - 2.0764\lambda^2 \right) \quad (7)$$

where, Blair (1999)  $\eta_{c \max} = 0.9$

To calculate the mass flow through the valve two situations are considered depending on the flow regime (i.e. relation between the pressures up and downstream). The flow rate through the valve is given by (Heywood, 1988):

$$\dot{m} = \frac{C_D A_r p_u}{(RT_u)^{1/2}} \left( \frac{p_d}{p_u} \right)^{\frac{1}{\gamma}} \left\{ \frac{2\gamma}{\gamma-1} \left[ 1 - \left( \frac{p_d}{p_u} \right)^{\frac{\gamma-1}{\gamma}} \right] \right\}^{1/2} \quad (8)$$

When the flow is choked, i.e. the flow speed equals the speed of sound:

$$\frac{p_d}{p_u} \leq \left( \frac{2}{\gamma+1} \right)^{\frac{\gamma}{\gamma-1}} \quad (9)$$

Then the flow rate is given by:

$$\dot{m} = \frac{C_D A_r p_u}{(RT_u)^{1/2}} \gamma^{1/2} \left( \frac{2}{\gamma+1} \right)^{(\gamma+1)/2(\gamma-1)} \quad (10)$$

Where  $C_D$  is the discharge coefficient,  $p_u$  and  $T_u$  are the upstream pressure and temperature respectively,  $p_d$  is the downstream pressure and  $R$  is the gas constant.

### 3. Entropy Generation

At exhaust valve opening, cylinder gases are still at high pressure and temperature. That enthalpy could be recovered if expanded until the environment pressure and temperature conditions. As these gases are freely released to the surroundings, that potential work is lost. Entropy generated in this process is calculated using the Gouy-Stodola theorem:

$$W_{\text{lost}} = T_0 \cdot S_{\text{gen}} \quad (11)$$

In the case of the free expansion process, the lost work is calculated by the enthalpy of the engine gases:

$$\dot{S}_{\text{gen,enthalpy}} = \sum_{\text{in}} \frac{\dot{m}}{T_0} (h - h_0) - \sum_{\text{out}} \frac{\dot{m}}{T_0} (h - h_0) \quad (12)$$

where  $h$  is the enthalpy of each chemical species inducted or exhausted from the cylinder and  $h_0$  is the enthalpy of the same chemical species at environment conditions, considering normal atmospheric conditions of pressure and temperature.

Entropy generated in a combustion process may be calculated using the adiabatic combustion chamber model. As there is no mass, heat or work transferred, any change in the system entropy during the combustion process is directly caused by the process itself. Entropy generation due to combustion can be calculated by the difference in entropy of the combustion products and reactants:

$$\dot{S}_{\text{gen,comb}} = \sum_{i=1}^n \dot{m}_{p_i} s_{p_i} - \sum_{i=1}^n \dot{m}_{r_i} s_{r_i} \quad (13)$$

where subscripts  $p_i$  and  $r_i$  are products and reactants respectively,  $s$  is the entropy and  $\dot{m}$  is the mass burning rate.

During the operation of the engine, heat is exchanged between the cylinder charge and the cylinder walls and then between the engine and the surrounding environment. Applying the second law of thermodynamics to the cylinder results in:

$$\dot{S}_{\text{gen,heat}} = \frac{\dot{Q}_w}{T_w} - \frac{\dot{Q}_{\text{cyl}}}{T_{\text{cyl}}} \quad (14)$$

where  $\dot{Q}_w$  and  $\dot{Q}_{\text{cyl}}$  is the heat transferred from the cylinder content to the cylinder walls.  $\dot{Q}_w$  and  $\dot{Q}_{\text{cyl}}$  have the same value but different signs and  $T_w$  and  $T_{\text{cyl}}$  are respectively the wall temperature and the cylinder gas temperature. As the heat is not stored at the engine walls but is transferred to the surroundings, equation (14) may be written as (Ribeiro, 2006):

$$\dot{S}_{\text{gen,heat}} = \frac{\dot{Q}(T_{\text{cyl}} - T_0)}{T_0 T_{\text{cyl}}} \quad (15)$$

where  $T_0$  is the environment temperature, considered as 25°C. The value of the heat transfer rate ( $\dot{Q}$ ) is calculated using the Annand heat transfer coefficient (Blair, 1999):

$$\dot{Q} = \frac{dQ}{dt} = (C_h + C_r)(T_{\text{cyl}} - T_w) m_{\text{cyl}} A_{\text{tr}} \quad (16)$$

where  $A_{tr}$  is the heat transfer area that is fixed for the engine head and piston and variable for the cylinder walls,  $T_{cyl}$  is the inside cylinder gas temperature and  $T_w$  is the wall (cylinder, piston or engine head) temperature, assumed as constant during the overall engine cycle. The radiation heat transfer coefficient ( $C_r$ ) is given by:

$$C_r = 4.25 \times 10^{-9} \frac{T_{cyl}^4 - T_w^4}{T_{cyl} - T_w} \quad (17)$$

The convection heat transfer coefficient ( $C_h$ ) is related to the Nusselt number ( $Nu = 0.49 Re^{0.7}$ ) as:

$$C_h = \frac{k_{cyl} Nu}{B} \quad (18)$$

where  $B$  is the cylinder bore,  $k_{cyl}$  the thermal conductivity of the gases inside the cylinder and  $Re$  is the Reynolds number

$$\left( Re = \frac{\rho_{cyl} u_p B}{\mu_{cyl}} \right).$$

Another source of energy loss during the engine working is internal friction. Friction is calculated using a proposed method (Sandoval, 2003). Entropy generation is calculated using again the Gouy-Stodola theorem (11):

$$\dot{S}_{gen, friction} = \frac{\dot{W}_{lost, friction}}{T_0} \quad (19)$$

when passing through a valve the gas flow suffers a pressure drop due to the valve and duct geometry. The engine spends work on overcoming this resistance to fluid flow. Considering a quasi-steady gas flow through the valve, the entropy generation rate can be calculated from the state properties:

$$\begin{aligned} \dot{S}_{gen, valve} &= \dot{m} \int_u^d ds = \dot{m} \left[ c_p \ln \left( \frac{T_u}{T_d} \right) - R \ln \left( \frac{p_u}{p_d} \right) \right] = \\ &= \dot{m} \left[ c_p \ln \left( 1 - \frac{\gamma-1}{2} M^2 \right) + c_p \frac{\gamma-1}{\gamma} \ln \left( \frac{p_u}{p_d} \right) \right] = \quad (20) \\ &= \dot{m} c_p \ln \left[ \left( 1 - \frac{\gamma-1}{2} M^2 \right) \left( \frac{p_u}{p_d} \right)^{\frac{\gamma-1}{\gamma}} \right] \end{aligned}$$

where:

$p_u$ ;  $p_d$  – gases pressure upstream and downstream of valve respectively;

$T_u$ ;  $T_d$  – gases temperature upstream and downstream of valve respectively;

$\gamma$  – heat capacity ratio:  $\gamma = \frac{c_p}{c_v}$

$M$  – Mach number of gases at valve inlet:

$$M = \frac{u}{c}$$

$u$  – velocity of gases in pipe

$c$  – sound velocity in gases:  $c = \sqrt{\gamma RT}$

Entropy is generated at the throttle valve in the case of the Otto cycle engine, and at the intake and exhaust valves for all the engines.

#### 4. Results

The model is used hereafter to calculate the entropy generated in an internal combustion engine working under the Otto cycle and the Miller cycle. The load of the Otto cycle is controlled by the intake pressure (throttle valve), while the load of the Miller cycle is controlled by the extent of the effective intake stroke (opening period of the intake valve). This obviously results in different effective compression ratios when the engine is running at part load (the Otto and the Miller engines at full load have the same CR as the Miller VCR engine at part load).

The following sections analyze each entropy generation mechanism and how it reacts to cycle changes. The simulations were performed in a single cylinder engine (211 cm<sup>3</sup>) running at 36% of load (3 bar bmep) and 2500 rpm. TABLE I describes various engine characteristics and working conditions.

Analyzing the importance of each of the entropy generating processes referred to above, one can see that the free expansion process is the most important (Figure 4). This is mainly caused by the blow-down effect after exhaust valve opening.

Combustion is the second entropy generating process, followed by heat transfer. These three processes are responsible for more than 80% of the total amount of entropy generated in the engine.

TABLE I. ENGINE CHARACTERISTICS AND WORKING CONDITIONS.

	Otto	Miller	Miller VCR
Bore x stroke [mm]	70 x 55		
Spark time [CA]	15 ° BTDC		
Burn duration [CA]	40		
IVC [° ABDC]	32	137	135
Geometric CR	11.5:1	11.5:1	19:1
Effective CR	3.1:1	2.4:1	4.2:1
Mean eff. pres. [bar]	3		
Fuel injected [mg]	6.72	5.56	4.76
$T_{max}$ [K]	1979	1958	1870
$P_{max}$ [bar]	25.9	21.8	29.5
$T_{exhaust}$ [K]	974	953	830
$P_{exhaust}$ [bar]	1.6	1.3	1.0

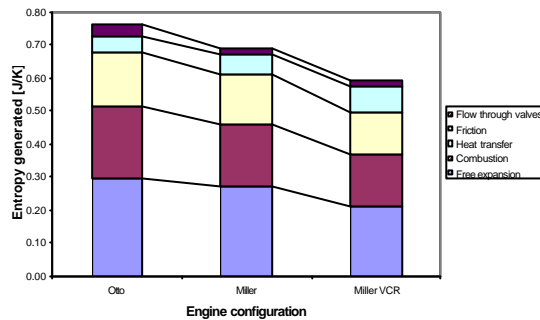

Figure 4. Entropy generated in each cycle.

#### 4.1. Free Expansion

During the mass exchange processes, intake and exhaust, the flow is achieved by the pressure differences across each valve. This difference of pressures leads to an expansion resulting in the exergy lost of the gases, or in other words, entropy generation. This phenomenon is more severe during the blow-down phase just after the exhaust valve opening. During this period the pressure inside the cylinder reduces suddenly and a great amount of mass flows out of the cylinder. In conventional spark ignition (Otto) engine, this mass of burned gases is at a significant high temperature (usually higher than 900K) and pressure (~1.5 bar) (TABLE ) and is completely released into the environment (considered at atmospheric conditions). As the over-expansion is increased, the pressure and temperature inside the engine at the exhaust valve opening are lower, leading to a reduced amount of entropy generated in this process (reduction by 29% when comparing the Otto and the Miller VCR engine cycles).

As it can be seen from Figure 4 (Table II) the difference between the Otto cycle and the Miller cycle is small because in both cycles, the load decreases with a decrease of the maximum temperature and pressure of the cycle, resulting in an approximately equal temperature and pressure at the exhaust valve opening. In the case of the Miller cycle, the benefits achieved by the over-expansion are almost the same as the losses due to the blow-back at the end of intake.

The Miller VCR cycle engine has a significantly lower amount of entropy generated (Table II) because the temperature and pressure at the exhaust valve opening are lower, despite the higher cycle peak pressure. In fact, in this cycle the rate of temperature and pressure decrease during expansion is higher due to the lower combustion volume (much smaller combustion chamber) and less mass (better efficiency).

The two methods to implement the Miller cycle (LIVC and EIVC) have different results in terms of entropy generated due to free expansion

at the intake stroke. The elimination of blow-back on the Miller cycle when EIVC is used makes the entropy generated at the intake be reduced by 39%. However at higher loads, when the blow-back is not so significant, the LIVC method may have less entropy generated at the intake than the EIVC method because with LIVC the intake valve has wider opening area.

TABLE II. ENTROPY GENERATED PER CYCLE (J/K).

	Otto	Miller	Miller VCR
Free expansion	0.294	0.271	0.208
Combustion	0.220	0.190	0.162
Heat transfer	0.162	0.148	0.127
Friction	0.050	0.063	0.076
Flow through valves	0.036	0.018	0.020
<b>TOTAL</b>	<b>0.762</b>	<b>0.691</b>	<b>0.593</b>

#### 4.2. Combustion

The entropy generated during combustion corresponds to the entropy increase due to the chemical reaction taking place inside the engine cylinder and heat transferred within that mass of gas. It depends mainly on three variables: the amount of fuel burned, the temperature and the pressure of the gases inside the engine. As can be seen from Table II, the entropy generated by this process decreases (by 14%) when the Miller cycle is used and decreases even more (by 26%) if VCR is used. In fact, with the Miller VCR cycle the maximum pressure in the cycle is higher but the temperature is slightly lower. With this increase of the pressure, the specific entropy of the burned gases decreases. However, the quantity of fuel needed to produce the same load reduces (by 29%), decreasing the amount of generated entropy.

#### 4.3. Heat Transfer

In internal combustion engines, the heat transfer is a significant process during the combustion and expansion stroke. In the rest of the cycle the value for heat transfer is small (due to the small difference between the in-cylinder gas temperature and the wall temperature) and the amount of heat that flows in and out of the engine is small. During combustion (when the maximum temperature is reached), the heat transfer from the engine gases to the cylinder walls is high.

Comparing the Miller cycle with the Otto cycle (Figure 4, Table II), there is a reduction of the amount of heat transferred and of the entropy generated due to this process, because the maximum cycle temperature in the Miller cycle is lower than in the Otto cycle. In the Miller VCR cycle engine, the entropy generated due to the

heat transfer is less (Table II). The combustion chamber in the case of the Miller VCR cycle is more compact, with less heat transfer area and the mean gas cycle temperature is also lower, leading to an overall reduction of the entropy generated due to heat transfer.

#### 4.4. Friction

The friction component of the entropy generated is the only one that increases when the engine is modified from Otto to Miller and even more when VCR is used (Table II). For the same load level and from the Otto to the Miller cycle, there is an increase of the intake pressure (considered as atmospheric on the Miller cycle), raising the pressure level of the cycle. When the cycle is changed to the Miller VCR, the intake pressure is higher than in the Otto cycle and the compression ratio increases, increasing even more engine friction. In terms of entropy generated, which is directly proportional to the work loss in friction, the increase is 52% from the Otto cycle to the Miller VCR cycle. Since the weight of the friction component of the entropy generated is low, there is no significant effect on the overall entropy generated in the cycle.

#### 4.5. Flow Through Valves

The mass flow through valves takes place during the intake and exhaust stroke in all the engines. The entropy generated by this process is a result of the friction of the gases on the surface of the elements of the valve and seat and in the throttle valve of the Otto cycle engine.

As can be seen from *Figure 4* (Table II), in the Otto cycle the entropy generated is significantly higher than in the Miller cycle, mainly because of the passage through the throttle valve. If this was not considered, the entropy generated in the cylinder valves would be lower than in any of the Miller cycles, because in the Otto cycle there is no back-flow to the intake manifold and the intake pressure is low. In the case of the Miller VCR, the amount of entropy generated is significantly higher when LIVC is used instead of the EIVC strategy. This is caused by the back-flow from the cylinder to the intake manifold during the upward movement of the piston.

#### 4.6. Overall Entropy Generation

From the analysis of the several entropy generating processes it is possible to determine the best strategy for improvement of internal combustion engines. It is possible therefore to establish that the recovering of the exergy destroyed during the free expansion, especially during the exhaust stroke, should be the main objective of engine development, because any improvement on that process may lead to a significant improvement in the overall entropy

generation. In fact, the absolute reduction of the entropy generated in the combustion process is 0.058 J/K, while the absolute reduction of the entropy generated in the free expansion process is 0.086 J/K.

From the above it can be seen that the Miller cycle with compression ratio adjustment can play a very important role in this achievement.

In terms of specific entropy generated (amount of entropy generated divided by the work produced by the engine - *Figure 5*). In both *Figures 4* and *5* it is possible to see that the Miller cycle engine with compression ratio adjustment is the most efficient engine. This means an improvement of 20.4% in the absolute entropy generated and 19.8% on the specific entropy generated in relation to the Otto cycle at similar load (3 bar bmep).

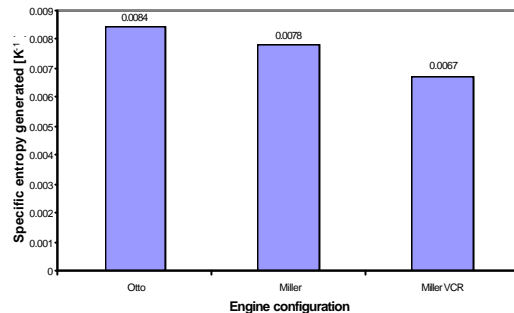

*Figure 5. Specific entropy generated per cycle.*

## 5. Conclusions

In this article the Otto cycle, the Miller cycle and the Miller cycle with compression ratio adjustment (Miller VCR) are compared under part load conditions. The EGM method was used to study the improvement of the use of the Miller cycle engines for automotive applications.

In a computer model implemented in Matlab Simulink it is possible to calculate and compare the several components of the entropy generation in an internal combustion engine. From these five main sources of entropy (combustion, free expansion, heat transfer, friction and flow through valves), the free expansion and combustion are the most important, always being responsible for more than 60% of the entropy generated for all the engine cycles studied.

If the Miller cycle is used, the amount of gases expanding at the exhaust blow-down is reduced and the entropy generated drops, obtaining more efficient engines.

Using the work and the entropy generated to determine the most efficient engine, it can be seen that the Miller cycle (with load controlled by the duration of the inlet valve opening) and compression ratio adjustment produces less entropy than the Otto cycle with the load controlled by a throttle valve.

The results obtained from the EGM model allow the establishment of an improvement direction for SI internal combustion engines when working under part load conditions. The improvement is obtained through the reduction of the entropy generated during the engine work, specially reducing the entropy generated due to free expansion at the exhaust process.

### List of Symbols

$A_r$  – cross flow area  
 $A_{tr}$  – heat transfer area  
 $B$  – cylinder bore  
 $c$  – sound velocity  
 $C_D$  – discharge coefficient  
 $C_h$  – convection heat transfer coef.  
 $c_v$  – specific heat capacity  
 $c_p$  – specific heat capacity  
 $C_r$  – radiation heat transfer coef.  
 $h$  – specific enthalpy  
 $k$  – thermal conductivity  
 $m$  – mass  
 $M$  – Mach number  
 $\dot{m}$  – mass rate  
 $Nu$  – Nusselt number  
 $p$  – pressure  
 $Q$  – heat  
 $Q_{LHV}$  – lower heating value  
 $Q_R$  – heat released  
 $\dot{Q}$  – heat rate  
 $R$  – gas constant  
 $Re$  – Reynolds number  
 $s$  – specific entropy  
 $\dot{S}_{gen}$  – rate of entropy generation  
 $t$  – time  
 $T$  – temperature  
 $u$  – velocity  
 $U$  – internal energy  
 $u_p$  – mean piston velocity  
 $V$  – volume  
 $W$  – work  
 $x_b$  – fraction of burned gases  
 $\gamma$  – heat capacity ratio  
 $\eta$  – efficiency  
 $\lambda$  – excess air  
 $\mu$  – viscosity  
 $\theta$  – crank angle  
 $\rho$  – density  
subscripts  
 $0$  – environmental  
 $c$  – combustion  
 $cyl$  – of the gas inside the cylinder  
 $d$  – downstream  
 $f$  – fuel  
 $in$  – entering  
 $m$  – mean value  
 $out$  – exiting  
 $p$  – products of combustion

$r$  – reactants  
 $u$  – upstream  
 $w$  – wall

### Abbreviations

ABDC – After Bottom Dead Center  
 BDC – Bottom Dead Center  
 BTDC – Before Top Dead Center  
 CA – Crank Angle  
 CR – Compression Ratio  
 EGM – Entropy Generation Minimization  
 EIVC – Early Intake Valve Closure  
 IVC – Intake Valve Closure  
 LIVC – Late Intake Valve Closure  
 VCR – Variable Compression Ratio  
 VVT – Variable Valve Timing

### Acknowledgments

Bernardo Ribeiro thanks the FCT and FSE (in the scope of QCA III) for the financial support given for his research activities. This work was funded by FCT/FEDER POCI/ENR/59168/2004.

### References

- Abd Alla, G. H., 2002, "Computer simulation of a four stroke spark ignition engine", *En. Convers. Mng.* N° 43, pp. 1043-1061.
- Bejan, A., 1994, *Entropy generation through heat and fluid flow*, John Wiley & Sons, New York.
- Bejan, A., 1996, *Entropy Generation Minimization*, CRC Press, Boca Raton.
- Bejan, A., 1997, *Advanced Engineering Thermodynamics*, Second Edition, John Wiley & Sons, New York.
- Bejan, A., 2002, "Fundamentals of exergy analysis, entropy generation minimization, and the generation of flow architecture", *Int. J. Energy Res.*, N° 26, pp.545-565.
- Blair, G. P., 1999 "Design and Simulation of Four-Stroke Engines", *SAE*.
- Drangel, H., Reinmann, R., Olofsson, E., 2002, "The Variable Compression (Svc) and the Combustion Control (Sec) – Two Ways to Improve Fuel Economy and Still Comply With World-Wide Emission Requirements", *SAE 2002-01-0996*.
- Flierl, R., Kluting, M., 2000, "The Third Generation of Valvetrains-New Fully Variable Valvetrains for Throttle-Free Load Control", *SAE 2000-01-1227*.
- Heywood, J. B., 1988, *Internal Combustion Engines Fundamentals*, McGraw-Hill.
- Martins, J., et al., 2004, «Thermodynamic analysis of an Over-Expanded Engine», *SAE 2004-01-0617*.

Ribeiro, B., 2006, "Thermodynamic Optimisation of Spark Ignition Engines at Part-Load Conditions", Ph.D Thesis, Universidade do Minho, Portugal.

Sandoval, D., Heywood, J., 2003, "An Improved Friction Model for Spark-Ignition Engines", *SAE 2003-01-0725*.