

Annex I

PCB Design

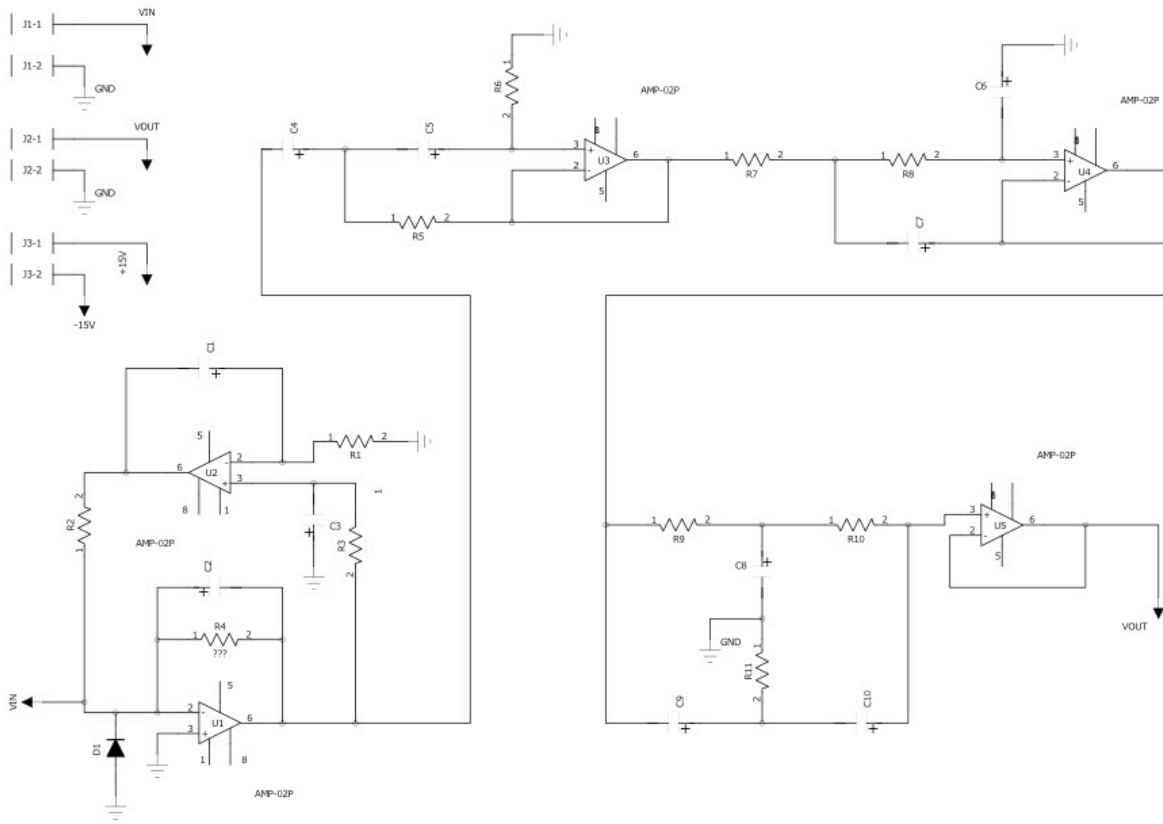

Figure I.1 Electrical circuit layout for PCB design.

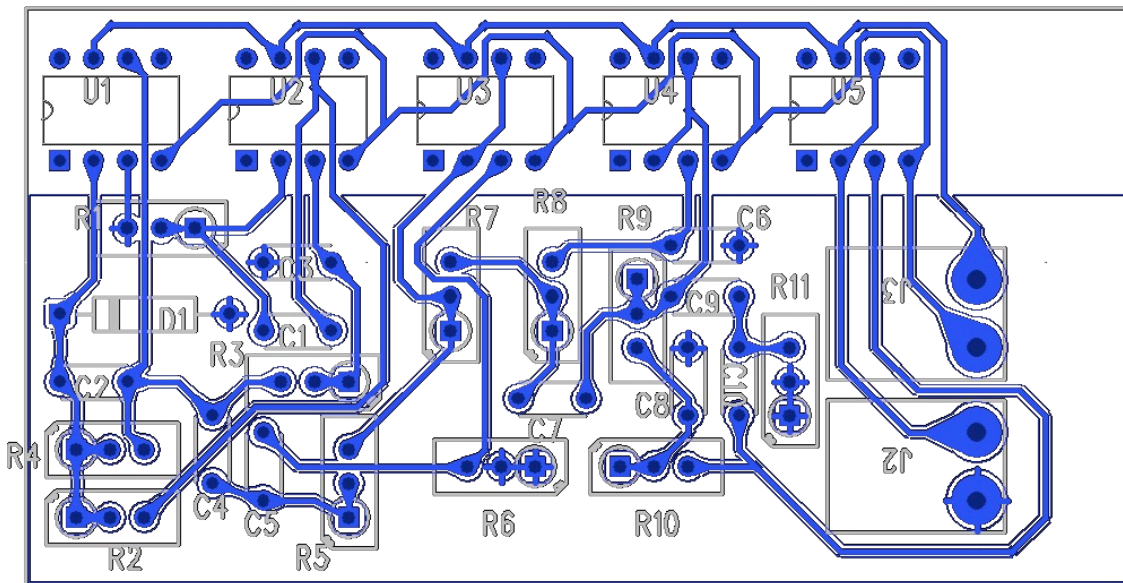

Figure I.2 OE system PCB layout.

Annex II

International Publications

Book Chapter

- AII.1** P. M. Mendes, C. P. Figueiredo, Mariana Fernandes and O. S. Gama, "Electronic in Medicine," Springer Handbook of Medical Technology, Part G, 1st edition, 2012, pp. 1337–1376.

1337

Electronics in

74. Electronics in Medicine

Paulo M. Mendes, Celso P. Figueiredo, Mariana Fernandes, Óscar S. Gama

Electronics has long made an undeniable and valuable contribution in the field of medicine. New medical electronic devices are based on available medical knowledge combined with technologies available in the electronics field. Electronics in medicine has a wide range of applications, from diagnostics to therapy, always aiming to provide new tools to improve the well-being of the population.

Nowadays, miniaturization and integration technologies are driving the development of new electronic medical devices that should be portable, wearable, and unobtrusive, but with controlled costs. Regardless of the technologies involved, usually the main goal of such devices is the measurement of physiological variables for use in diagnostics, monitoring, and therapy.

Therefore, this chapter starts with the description of several signals that are commonly recorded, the corresponding electronics and sensing mechanisms used, and problems associated with such acquisition systems, focusing on wireless and wearable devices. It ends with examples of electronic devices in development essentially for remote health monitoring.

This chapter is not about electronics nor on their design, since there are many good books on this topic already, written either specifically for the (bio)medical field or for the general field of electronics. The aim of this chapter is rather to present to the reader those aspects that are common and specific to many medical electronic devices, and to give an overview of what is required and the challenges faced when designing electronics in this field as well as a few such examples under development.

74.1	Basics	1338
74.1.1	Fields of Application	1338
74.1.2	Designing Electronics in Medicine	1339
74.1.3	Medical Electronics Specific Requirements	1339
74.2	Electronic Sensing	1341
74.2.1	Health Condition Monitoring	1341
74.2.2	Biosignals and Transducers	1342
74.3	Electronics for Wireless Health Monitoring	1344
74.3.1	Requirements for Wireless Devices	1345
74.3.2	Data Acquisition	1346
74.3.3	System Integration	1347
74.3.4	Wireless Communications	1348
74.4	Power Supply	1348
74.4.1	Battery Power Budget Considerations	1349
74.4.2	Wireless Power	1350
74.4.3	Wireless Power Link Analysis	1350
74.4.4	Wireless Power Charger	1351
74.4.5	Energy Harvesting	1352
74.5	Wearable Medical Electronics	1353
74.5.1	Wearable Systems	1355
74.5.2	Categories of Wearable Systems ...	1355
74.5.3	Design Requirements	1356
74.5.4	Sensors for Wearable Systems	1357
74.5.5	Sensing Methodologies	1357
74.6	Electronics in Medicine at Work	1358
74.6.1	Wireless and Wearable Low-Power Health Monitoring Systems	1359
74.6.2	Sensors	1359
74.6.3	Wireless Link	1360
74.6.4	Optical Biopotential Recording	1360
74.6.5	Optical Electrodes	1361
74.6.6	Optical Signal Acquisition	1361
74.6.7	Localization Solutions	1361
74.6.8	Ambient Assisted Living Applications	1363
74.6.9	Wireless Link Design for Biomedical Applications	1366
	References	1373

Conference Publications

Oral communications

- AII.2** M. Fernandes, K.S. Lee, R. J. Ram, J. H. Correia and P. M. Mendes, "Flexible PDMS - based dry electrodes for electro-optic acquisition of ECG signals in wearable devices", 32nd Annual International Conference of the IEEE Engineering in Medicine and Biology Society, Buenos Aires, Argentina, 31 August - 4 September, 2010.
- AII.3** M.S. Fernandes, C.M. Pereira, J.H. Correia and P.M. Mendes, " Bioelectric Activity Recording based on Single Electrode for use on Wearable Devices", BIODEVICES 2011 - Proceedings of the International Conference on Biomedical Electronics and Devices, Rome, Italy, January 26-29, 2011.
- AII.4** M. Fernandes, J.Higino Correia and P. Mateus Mendes, "Electro-optic electrodes based on Lithium Niobate Mach Zehnder Interferometer Modulators for wearable bioelectric activity recording", AOP2011 – Proceedings of the International Conference on Applications of Optics and Photonics, Braga, Portugal, May 3-7, 2011

Poster communications

- AII.5** M. Fernandes, N. S. Dias, J. Nunes, M. E. Tahchi, S. Lanceros-Méndez, J. H. Correia, P. M. Mendes, "Wearable Brain Cap with Contactless Electroencephalogram Measurement for Brain-Computer Interface Applications," 4th International IEEE EMBS Conference on Neural Engineering, pp.387-390, Antalya, Turkey, 29 April- 2 May, 2009.

Journal Publications

- AII. 6** M.S. Fernandes, N.S. Dias, A.F. Silva, J.S. Nunes, S. Lanceros-Méndez, J.H. Correia, and P. M. Mendes, "Hydrogel-based photonic sensor for a biopotential wearable recording system", *Biosensors and Bioelectronics*, vol. 26, 2010, pp. 80- 86.

The full paper is attached in the following pages.



Hydrogel-based photonic sensor for a biopotential wearable recording system

Mariana S. Fernandes^{a,*}, Nuno S. Dias^a, Alexandre F. Silva^a, Jivago S. Nunes^b, Senentxu Lanceros-Méndez^b, José H. Correia^a, Paulo M. Mendes^a

^a Department of Industrial Electronics, University of Minho, Campus Azurém, 4800-058 Guimarães, Portugal

^b Department of Physics, University of Minho, 4710-057 Braga, Portugal

ARTICLE INFO

Article history:

Received 5 February 2010

Received in revised form 22 April 2010

Accepted 6 May 2010

Available online 13 May 2010

Keywords:

Wearable braincap

Contactless sensor

Brain–computer interface

Ambient-assisted living

ABSTRACT

Wearable devices are used to record several physiological signals, providing unobtrusive and continuous monitoring. These systems are of particular interest for applications such as ambient-assisted living (AAL), which deals with the use of technologies, like brain–computer interface (BCI). The main challenge in these applications is to develop new wearable solutions for acquisition of electroencephalogram (EEG) signals. Conventional solutions based on brain caps, are difficult and uncomfortable to wear. This work presents a new optical fiber biosensor based on electro-active gel – polyacrylamide (PAAM) hydrogel – with the ability to measure the required EEG signals and whose technology principle leads to contactless electrodes. Experiments were performed in order to evaluate the electro-active properties of the hydrogel and its frequency response, using an electric and optical setup. A sinusoidal electric field was applied to the hydrogel while the light passes through the sample. An optical detector was used to collect the resultant modulated light. The results have shown an adequate sensitivity in the range of μV , as well as a good frequency response, pointing the PAAM hydrogel sensor as an eligible sensing component for wearable biopotential recording applications.

© 2010 Elsevier B.V. All rights reserved.

1. Introduction

The ambient-assisted living (AAL) technologies aim to help people and must be as ubiquitous as possible. A very important challenge is to obtain devices that can be wore by people as they do with regular garments. The sensors and actuators must be designed to perform their functions, while being wearable. This requires the development of an all-new set of wearable sensors with the ability to record several physical variables, depending on the device application.

A very important AAL technology is known as brain–computer interface (BCI), which relies on the measurement of brain activity in order to provide solutions for communication and for environmental control without movement. Although a BCI was initially intended for people with severe disabilities (e.g. spinal cord injury, brainstem stroke, etc.), it may also be used as an alternative communication path for healthy people (Wolpaw et al., 2002).

Over the past two decades, several studies were performed towards the development of these BCI systems, which do not

require muscle control (Farwell and Donchin, 1988; Neuper et al., 2003; Pfurtscheller et al., 1993, 2003). Although still in its infancy, BCI is no longer a realm of science fiction, but an evolving area of research and applications. BCI propose to increase human capabilities by enabling people to interact with a computer through a modulation of their brainwaves after a short training period. They are indeed, brain-actuated systems that provide alternative channels for communication, entertainment and control (Dornhege et al., 2007). Nowadays, the typical BCI systems measure specific features of brain activity and translate them into device control signals, generally making use of electroencephalogram (EEG) acquisition techniques, thus requiring wearable devices being able to record the scalp electrical signals.

An EEG corresponds to potential changes occurring over time between the recording electrode and reference electrode (Kondraske, 1986). There are two main techniques that can be used to record scalp potentials, i.e. EEG: electronic and electro-optic (EO) methods. The first one involves the use of electrodes attached to the scalp, amplifiers, filters, and a recording device. They are usually based on caps with adaptors for electrode's mounting, usually according to 10–20 electrode placement system (Klem et al., 1999). The scalp electrodes most common in EEG caps consist of Ag/AgCl disks with long flexible leads, which can be plugged into an amplifier (Bronzino, 1995). One of the first electrode caps available was

* Corresponding author. Tel.: +351 253 604700/604704; fax: +351 253510189.

E-mail addresses: mfernandes@dei.uminho.pt, marianasfernandes@gmail.com (M.S. Fernandes).

developed and patented by Corbett (1985), comprising a cap with spaced electrode anchoring tabs. This type of electrode caps has significant disadvantages: the scalp must be cleaned and/or an electrolytic gel needs to be applied to form an electrical connection with the metal electrodes, which may cause scalp irritation over prolonged utilization. Moreover, it requires time consuming and complex attachment procedures. These limitations have driven the need for new electrode caps, based on dry electrodes that do not require this site preparation and offers other advantages such as: reduction of experimental preparation time, higher length of studies and more comfortable caps. QUASAR, Inc. has been developing prototypes of electrode caps based on dry electrodes, more specifically high impedance hybrid capacitive/resistive electrodes (Matthews et al., 2007). However, despite the progress in EEG caps, there is still lacking a totally wearable solution, with highly flexible electrodes and in preference, requiring no contact with the scalp.

The second technique uses the bioelectric signal to drive an electro-optic material or device that will further manipulate light, changing its properties. This will give origin to an optical signal that is converted into the original EEG signal. A high impedance EO probe for the acquisition of biopotentials based on the EO effect, was recently developed (Kingsley et al., 2004). In their work, Sriram and Kingsley, described a sensor that enables dry contact measurements of EEG and ECG signals. However, there is still some work to do in order to assemble the sensors into a flexible wearable braincap.

This paper will present a new type of photonic sensor for a wearable brain cap to record the scalp electrical signals, for enabling the possibility of a contactless record of EEG. This approach can surpass the common limitations associated with the current available technologies, since by using optical methods the integration into wearable materials is facilitated, allowing to design comfortable and totally wearable devices. First, a brief description of a wearable electrophysiological monitoring device is made, as well as of the EEG signal characterization and respective standard readout. Then the photonic sensor proposed will be exposed as well as the integration technique into the wearable device, followed by the measurements and respective results.

2. Wearable electrophysiological monitoring device

One of the most demanding goals to implement healthcare support technologies is the measurement and monitoring of physiological signals, since they hold rich and constantly demanding clinical information, without interfering with daily activities. These requirements can be answered through multifunctional fabrics, giving origin to wearable monitoring systems. In fact, with these new high-knowledge-content garments, an all-in-one solution for the measurement of biopotentials can be achieved.

Electrophysiological variables represent a very particular class of electrical signals, with low-frequency components and magnitudes, and they are a result of the electrochemical activity of a certain class of cells – excitable cells (Clark, 1998). There are several types of biopotentials, which are classified according to the type of activity that they are originated from. Therefore, they include signals originated from brain activity (electroencephalogram – EEG), heart activity (electrocardiogram – ECG), muscle activity (electromyogram – EMG) and ocular activity (electrooculogram – EOG) (Clark, 1998).

The importance of EEG signals not only for BCI applications but also for clinical purposes as well as the lack of practical and wearable EEG recording solutions, has contributed for the main goal of this work. Therefore, in the next sub-sections the EEG will be characterized as well as the standard readout and a wearable brain cap will be proposed.

2.1. EEG test pilot and standard readout

In order to record very weak biopotentials, as the EEG, two main components are required:

- a differential amplifier with a high-input impedance;
- low-impedance electrodes.

The instrumentation amplifier is commonly used to record biopotentials since it is designed to have extremely high-input impedance and a small bias current. Electrodes with very small contact impedance are required in order to make this an effective solution. Otherwise the currents driving the instrumentation amplifier would lead to a biopotential drop, resulting in more difficult readouts. Two types of electrodes are used in EEG recordings: wet and dry electrodes. The first one is a metal-based element, which makes use of an electrolyte gel/paste to promote electrical connection between the electrode and the skin. The second type of electrodes consists of a metal or semiconductor with a dielectric surface layer, and the signal is capacitively coupled from the skin to the electrode. Several EEG dry electrodes were proposed, and can be found in (Matthews et al., 2007; Sellers et al., 2009; Taheri et al., 1994). Alternative dry solutions suggest a set of spikes that are grown on the top of the electrode, also leading to a reduction of the contact impedance (Ng et al., 2009). Despite the availability of dry electrodes, claimed to have similar properties to the wet electrodes, the wet solution is usually preferred.

The standard solutions show two main problems: the electrodes are difficult to integrate with the vests and to wear. When looking for an integration solution we are faced with the problem of electrode integration, wiring integration, and electronics integration and connection. All of the proposed solutions end up with, at least, how do we fabricate it at an industrial level. The other problem, a solution that can be dressed easily, is by far more difficult to solve. Even if we consider that we have a braincap with all the electronics integrated, the available electrodes do not allow for users to dress it at home. A new generation of electrodes is required.

In terms of the EEG characterization, its electric field (E) is related with the electrical potential difference (ΔV) between two points (recording and reference electrode), according to the following equation:

$$E = \frac{\Delta V}{d}, \quad (1)$$

where d is the distance between the recording and the reference electrode. In this way, the EEG waveform detected using electric field or potential difference measurements is the same. We have acquired human scalp EEG from a 23-year-old subject (male) in order to determine an approximate value of the electric field resultant from brain activity under a relaxed state. In fact, once the EEG signals are hard to predict and also difficult to standardize, this data will be valuable for understanding the type of signals we are dealing with. Information such as signal amplitude and frequency range is, indeed, crucial when designing a recording device. Therefore, the electrodes configuration used to perform the experiment was based on the approach proposed, allowing to simulate as much as possible the type of signals we expect to measure with our sensors.

We used three electrodes for the recording procedure: one working electrode (position Cz), a reference (Ref) on the back neck and the subject ground. The results obtained are depicted in Fig. 1.

As shown in Fig. 1, the scalp potential obtained has a magnitude near 75 μV for a distance between electrodes of 25 cm. Taking this into account, we determined the corresponding electric field of 3 $\mu V/cm$.

The results obtained are in conformity with the literature, since the typical values reported range from 50 to 200 μV (Kandel and

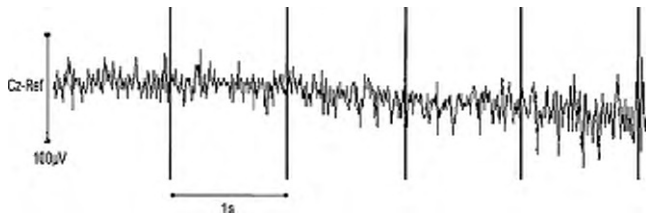

Fig. 1. Scalp EEG recorded waves for Cz-Ref.

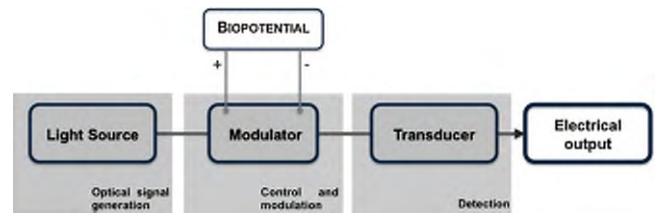

Fig. 3. Main functional stages of the optical sensor.

Schwartz, 2000). In terms of frequency range, it can vary from 0.5 to 100 Hz, and different brainwaves can be classified according to its frequency component: delta (up to 3 Hz), theta (4–7 Hz), alpha (8–12 Hz), beta (12–30 Hz) and gamma (26–100 Hz) (Azzini and Tettamanzi, 2006).

2.2. Wearable braincap

One main challenge for designing a wearable cap for EEG recording is to find new solutions for recording electrodes. Many attempts have been made, using different approaches, however they are not suitable for use on truly wearable devices (Ko et al., 2009; Maggi et al., 2008; Yates et al., 2007). In fact, the development of sensors for wearable applications has to take into account properties such as: easy integration and miniaturization, lightweight, flexibility, low-power consumption and real time monitoring (Winters and Wang, 2003).

The wearable braincap proposed allows the use of a new generation of fiber-optic-based sensors that, besides having the previous stated properties, also aims for a contactless recording. Consequently, the disadvantages concerning the use of the standard EEG tests will be surpassed by the use of contactless sensors, since the electrolyte gel will not be needed, neither the time consuming and uncomfortable attachment procedures. Moreover, unlike other contactless techniques, such as near infrared spectroscopy or magnetoencephalography, the proposed sensors actually measure brain activity as standard electric potentials, likely to EEG recordings.

The use of a probe to measure the electric field may lead to a problem since the standard EEG measurements are obtained as a potential difference between two scalp points. Using a standard electric field probe, only a local potential difference will be measured. In order to overcome this problem, Fig. 2 depicts the proposed scheme based on one-reference approach.

The standard setup uses the ear lobes as a reference signal, since most of the times they are not influenced by the electrical activity of the temporal lobe or by the muscle activity. However, from the user perspective, it would be better to hide the reference, since the objective is to allow the use of the brain cap as a normal daily garment. In this work, the suggestion is to place the reference on the

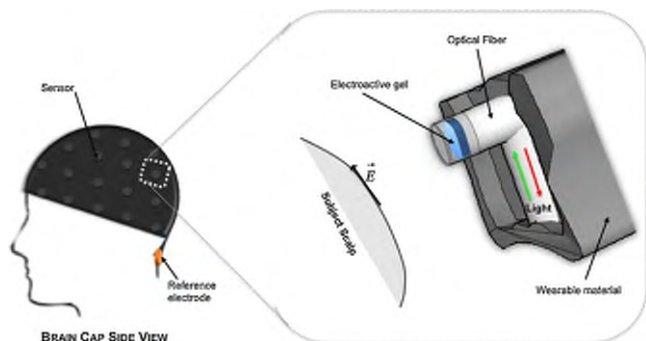

Fig. 2. One-reference approach. The photonic sensor is highlighted.

back neck, as illustrated in Fig. 2. Using this approach, two problems are avoided: first, the electric field magnitude would certainly be higher, since the distance between the working electrodes and the reference increases, enabling easier detection of electric field; second, all the potentials will be simultaneously measured without any contact at the recording locations and with the same reference. In this way, only the reference establishes contact with the subject skin.

3. Photonic sensor for the wearable brain cap

Due to the level of integration required, an optical readout method is proposed. This method uses optical sensors placed at the fiber tips in order to sense the electric field, i.e. the biopotential. Each fiber is then used to route the sensed biopotential to the readout device. In this way, a net of optical fibers is required to provide access to all the desired biopotentials, as depicted in Fig. 2. With this method, the integration requires only an optical fiber network integrated within the brain cap. That integration method will be explained in a subsequent section.

The readout solution is based on a fiber-optic sensor that relies on the electro-active principle, in order to use electric field to modulate an optical signal. The main functional stages of this sensor are depicted in Fig. 3 and are: optical signal generation; control and modulation; and detection.

Briefly, the first stage uses a light source to generate an optical signal that will be fed to the modulator. The same light source can be shared by all sensors, through the optical fiber network. In a second stage, the modulator, which may be based on an electro-active coating material, like a hydrogel or other piezoelectric material, will change a specific light property (e.g. polarization, intensity). For detection, the modulated light is guided to a photodetector for measurement. The light property modification observed is proportional to the biopotential itself, being therefore possible to translate this result into a biopotential recording.

The main advantages of these electrodes are: they do not require any contact with the surface to be measured, and they allow a high-degree of miniaturization. The contact is avoided, since they measure the electric field and not the potential, as the traditional solution does. This may also be achieved using an instrumentation amplifier to read the electric field, instead of a voltage. However, the use of integrated circuits will make the integration more difficult.

The sensor's miniaturization is possible and does not consist a problem since smaller electrodes lead to higher input impedances, which is exactly one of the desired conditions for devices used to record biopotentials. In this way, the smaller the electrode, the larger the input impedance obtained. The device size will be limited mainly by the length of interaction between the electric field and optical sensor.

Many solutions may be envisioned to obtain an optical sensor, leading to an optical electrode. One can be based, for instance, on conventional electro-optic modulators (Kingsley et al., 2004). However those solutions may become very bulky for integration on a wearable braincap. The desirable solution could be a fiber pigtail, with the electric field sensor on its tip. The proposed methodol-

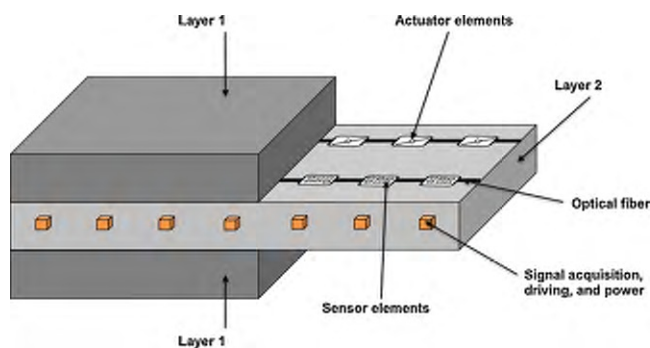

Fig. 4. Sandwiched three-layer scheme of a wearable device fabric.

ogy uses an electro-active hydrogel that, besides being of low cost, allows for the easy modification of its physical and chemical properties (Bassil et al., 2008; Osada and Gong, 1998). The hydrogel is constrained at the end of the optical fiber, as near as possible to the subject scalp in order to increase the detection sensitivity. Special attention must be taken while constraining the gel. In fact, it has been a problem for several years (Paxton, 2006). However, recent advances in this field have allowed the use of micromechanical techniques to design high-sensitive hydrogel-based sensors (Richter et al., 2008). An attractive and appropriate solution for our system could be based on what Hilt et al. (2003) described, where a stimulus-based hydrogel is used to functionalize a microcantilever structure for pH detection.

When submitted to an electric field, a deformation of the gel occurs and as a consequence, its distribution on the fiber tip will change. Therefore, if the gel expands after submitted to an electric field, it will occupy more fiber tip space, becoming a barrier for light transmission. Therefore, the amount of light transmitted will change, as well as the refractive index, causing light modulation.

4. Sensor integration on the wearable cap

The fabrication technique used to design the device is based on the multilayer integration of different types of materials, allowing for the integration of several components, e.g. sensors, actuators, optical fibers, electrical wires, antennas. This integration is made concurrently with the deposition and resorting to printing techniques. The layers can be composed of different materials such as polymeric, metal, or synthetic materials. For instance, the fabric could consist of a polymeric material sandwiched in a synthetic layer, and the sensors and actuators, or even other components would be printed, for instance, in the polymeric layer (Fig. 4).

The smart structure based on the integration of smart sensors in polymeric foils is mainly restrained by the fabrication technique in industrial environment. The majority of the common polymeric foils, with some customization possibility, are based on the spread-coating process.

4.1. Integration technology

When developing a flexible sensing structure, the need for an easy to apply product becomes evident. In this context, the sensing product should be easily handled, where the possibility to damage the integrated optical sensing elements must be as small as possible.

Moreover, it is important to ensure a good bonding between the sensor and the foil substrate to ensure the minimum sensitivity loss by the polymeric component. Also, the thickness of the whole structure should be as small as possible, or at least,

the distance between the integrated sensor and the host structure should be minimized. This ensures that, the existent polymeric layer between the host structure and sensor is reduced, guaranteeing the maximum transference of stimuli from the host. Other requirement for the structure is its ability to be applied in regular and irregular surfaces, enabling a broader application field. This feature requires flexibility and dimensional stability from the sensing structure to sustain some application methods (Silva et al., 2008).

4.2. Fabrication technique

The fabrication technique is based on an industrial process, which allows for the fabrication of very large flexible substrates with integrated sensors that can be tailored to obtain a brain cap, or any other flexible smart sensing structure. This technique consists in the deposition of one or more layers of plastisols on a support, such as paper, that is cured afterwards in ovens (Silva et al., 2010). Because of its versatility, this technique constitutes an optimal choice for the development of flexible optical sensing foils.

The spread-coating process consists on the plastisol spreading over the substrate or carrier (e.g. release paper) fixed on a metal frame. The movement of the carrier makes the plastisol pass through a gap between the knife and the substrate, scrapping off the excess of plastisol and ensuring a homogeneous thickness. The amount of applied plastisol is controlled by the adjustment of the gap between knife and substrate. After the coating application as uniform plastisol layer over the substrate, the whole metal frame is inserted in the oven to cure. After heated above the curing-temperature (130–400 °C), the polymer becomes homogeneous and a solid phase results.

4.3. Structure layout

With the requirements of ease handling, reduce interference by the polymeric layer, structure flexibility and dimensional stability, optical fibers and sensors integration should be done by inserting them directly in the carrier matrix and not bonding the optical elements on the carrier surface. With the sensors inside the polymeric matrix is possible to guarantee a better bonding of optical fiber with the polymeric matrix, and subsequently a better transfer of stimuli from the host material to the sensor.

For this purpose, a multilayer structure approach is considered the most suitable. The layer #1 plays the role of a protective skin for the optical fiber. This will be the visible layer when applying the structure. Thus, this layer has the possibility to be fully customized in terms of surface texture and color. Optical fibers are flexible and can be easily bent but they always tend to recover their initial shape. It is therefore mandatory to bond the fiber to the substrate over which it is deposited. The use of adhesive polymers was avoided by an intermediate layer (layer #2). The density and, especially, the whole formulation of this layer are responsible for the fiber adhesion to the carrier and for keeping it steady in its place. Finally a third layer is applied as an interface layer between the sensing foil and host structure. The material chose for the layers was polyvinyl chloride (PVC). Plasticized PVC has a good cost/performance ratio and uses simplicity during manufacturing processes. Furthermore, PVC exhibits many advantages like high-competitive production costs, high versatility, high resistance to ageing and ease of maintenance.

4.4. Fabricated devices

For prototyping, a laboratory scale setup was used to implement the industrial process conditions and is perfectly suitable for

industrial scale-up. The above-described process enables the production of prototypes with A4 dimensions. The final result is a third layer structure, and a sample of the polymeric fabricated with this technique can be found in (Silva et al., 2010). The optic fibers and sensors embedded in the sample material, as well the flexibility of the fabricated material, facilitates its use in a wearable device and in particular to the wearable braincap.

After applying the fabrication steps described, the final result was, at naked eye, a normal fabric that may be used to fabricate a common t-shirt, or even a scuba diving suit. In this case, we are able to design a normal and wearable cap or even, if necessary, a normal swimming cap.

5. Electric field photonic sensor

In order to validate the use of a hydrogel-based photonic sensor in the wearable brain cap system proposed, we studied some parameters through a set of experimental protocols. We performed some tests to evaluate the electro-active properties of the selected hydrogel, in order to obtain the minimum electric field that could be detected with its use as a sensing element.

Polyacrylamide (PAAM) hydrogel is an electro-active polymer with great sensing capabilities to physical, chemical and biological environments and response to external stimulus in a controllable way. PAAM shows abrupt and vast volume changes as well as bending phenomena when submitted to an external electric field (Bassil et al., 2008).

5.1. Electro-active hydrogel

The electro-active hydrogel used as the sensing component of our sensor is the PAAM hydrogel. When submitted to an external electric field, PAAM undergoes a bending process, altering its mass and volume properties. Likewise, an input light passing through this hydrogel will experience modifications, not only regarding the refractive index, but also the amount of light that is transmitted back to the photodetector.

An acrylamide 99%, N,N'-methylenebisacrylamide (BIS) 98% as cross-linker, N,N,N',N' tetramethylethylenediamine 99% (TEMED), ammonium persulfate 98% (APS) and aniline purum 99% were used to obtain the PAAM hydrogel. All chemicals were purchased from Aldrich and used as received without any further purification. Deionized water was used for all the dilutions, the polymerization reactions, as well as for the gel swelling. PAAM is synthesized by the standard free radical polymerization method using 1 ml acrylamide (30%), 60 μ l APS (25%), 20 μ l Temed with no cross-linker under vacuum. After complete polymerization, the resulting gel was diluted in 4 ml of deionized water and 5 ml Acrylamide (30%), 250 μ l BIS (2%), 10 μ l APS (25%) and 4 μ l Temed was added to form the precursor solution. A comprehensive study of the properties of PAAM hydrogel may be found on Bassil et al. (2008).

5.2. Experimental setup for sensor characterization

The electro-active properties of PAAM gel were evaluated by an experimental setup consisting of an electric and optical stage. The gel was placed between two copper electrodes inside a beaker, and a sinusoidal electric field was applied. Fig. 5 depicts the experimental setup used to test the electro-active properties of the PAAM gel.

As shown above, the optical stage is composed of: a 250-W quartz-tungsten-halogen (QTH) lamp in an Oriel Housing (66881, Oriel Instruments) is used as the light source with variable power, a monochromator (Cornerstone 130™, Oriel Instruments), an optical fiber, a detection module based on a photodiode (S1336-5BQ, Hamamatsu) with a photosensitivity of 0.26 A/W at a wavelength

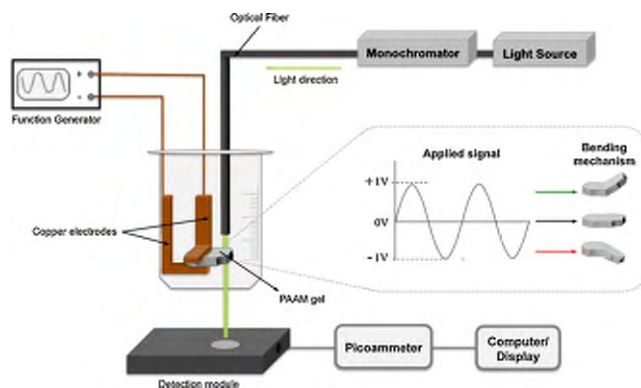

Fig. 5. Experimental setup for testing the electro-active properties of PAAM gel.

of 510 nm, a picoammeter (467, Keithley Instruments) and a computer with an in-house software acquisition. Light passes through the gel and the amount of light that passes through is collected at the detection module. On the other hand, at the electrical stage, an electric field was generated by applying a differential voltage of 10 V at different frequencies, between both copper electrodes.

6. Results and discussion

The following sub-sections will expose the results and respective discussion, whose relevance is of extreme importance since they define the applicability of hydrogel-based sensors in a wearable braincap. First, the exhibited PAAM hydrogel electro-optic translation mechanism is explained. Next, the results regarding the sensor response to electric fields and its frequency response are shown and discussed. These last sets of results are very important in characterizing the sensor sensitivity and frequency range.

6.1. Electro-optic translation mechanism

Due to its electro-active property, the gel will go under a few alterations when submitted to an external electric field. When applying a sine wave function the gel will bend towards the positive pole and therefore it will oscillate up and down at the selected frequency. As a result, when a beam passes through the gel, the amount of light that hits the photodetection stage will change, i.e. the light that was not attenuated by the sample. In other words, at the interface between the two mediums (air and PAAM hydrogel), the difference in their refractive index will cause light refraction. However, part of this light is reflected when the beam reaches the gel surface, causing light attenuation. This can be due to two main reasons: changes in refractive index due to density alteration when the gel bends; different angles of interaction with the sample surface.

Once we are causing the gel to bend, its density suffers alterations and consequently so does the refractive index. As the gel bends towards the positive pole, its density decreases as it shrinks, causing an increase on the refractive index. Therefore, it will facilitate light entry across the gel sample, which was experimentally confirmed. The opposite occurs when the gel bend towards the cathode.

Another possible explanation would be at the level of interaction of the light beam with the surface of the gel sample, i.e. angles of incidence. The critical angle plays one of the most important roles in the reflection phenomena, since it is the main determinant of total internal reflection. In fact, if the angle of incidence exceeds the critical angle, all the light is reflected.

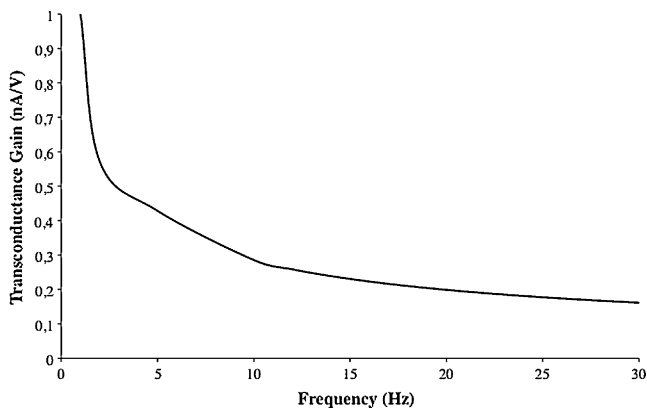

Fig. 6. Frequency response of PAAM hydrogel.

6.2. Sensor response to electric fields

In terms of sensitivity, the experimental setup included a 1 V-generated electric field, which produced differences in light intensity of approximately 0.4 nA. Since one of the most important requirements for biopotential sensors is its smaller size, it is important to use thin hydrogel samples. This is actually a benefit for our application, since according to Bassil et al. (2008) it is possible to establish a linear relationship between the amount of electrical power applied and the thickness of the hydrogel sample. In fact, the displacement of a thicker sample implies an increase of its mass and consequently more electrical power to move instantaneously. This linear relationship between the electric field and the sample thickness, allows to roughly estimate what would be the electric field needed to obtain the same bending. Therefore, if the gel is constrained according to the design described in Hilt et al. (2003), a PAAM hydrogel thickness of 2.2 μm can be used, and in this case the electric field needed to result in the same bending is 2.2 μV . Taking into account that the sensitivity of the picoammeter is 0.01 pA, and that EEG amplitudes are usually above 2.2 μV , this approach is able to record signals in the necessary range.

These results contribute to the recommendation of these sensors for wearable EEG acquisition systems, in particular braincaps, since they have shown the recommended sensitivity. In addition and in opposition to other acquisition techniques, our approach proves to perform better as we reduce the length scale. The use of optical fiber-based sensors is also an improvement since some drawbacks of the available EEG acquisition systems can be surpassed, such as: electromagnetic interference, need for electrical wires, low flexibility, integration problems, contact requirement, resistance to harsh environments, and others.

6.3. Sensor frequency response

One of the most important parameters of a transducer is its frequency response, because it determines its ability to reproduce the signals at the transducer input. As a result, we determined the frequency response for the developed sensor, and the result is depicted in Fig. 6.

As shown in Fig. 6, we were able to acquire a signal over the entire frequency range selected, and according to the EEG frequency components stated before, this hydrogel is suitable for the detection of important brainwaves, such as delta, theta, alpha and part of beta brainwave. However, some fluctuations in the optical signal amplitude were seen, due to limitations in the picoammeter.

According to Bassil (2008), the time required for the sample to bend increases linearly with its thickness, which means that the frequency response of PAAM hydrogel improves with very

thin samples. Considering the EEG frequency range and the gel frequency response, PAAM hydrogel is an eligible electro-active material to be used as a brain biopotential transducer.

7. Conclusion

A new generation of wearable electrodes for brain potential measurement, based in an innovative wearable brain cap integration technique, was proposed. The sensor was designed to respond to an electric field, instead of an electric potential, opening the opportunity to design new electrodes that require no contact between their surface and the subject skin, avoiding time consuming and uncomfortable attachment procedures. This fiber-based integration approach, which basis of operation relies on the electro-active principle, making much easier the integration of electrical field sensors in wearable devices. The electro-active hydrogel was tested as a candidate for the sensing/modulator component – PAAM, showing an adequate sensitivity and frequency response, as well as the ability to perform better as sample thickness decreases, placing it as an eligible sensing component for biopotential recording applications.

Acknowledgments

The authors would like to acknowledge Professor Graça Minas (Department of Industrial Electronics, University of Minho) for making available the necessary equipments and materials for the performed experiments. Mariana S. Fernandes, Nuno S. Dias and Alexandre F. Silva are supported by Center Algoritmi and the Portuguese Foundation for Science and Technology under the Grants SFRH/BD/42705/2007, SFRH/BD/21529/2005 and SFRH/BD/39459/2007, respectively.

References

- Azzini, A., Tettamanzi, A.B., 2006. *Comput. Sci.* 390, 500–504.
- Bassil, M., Davenas, J., EL Tahchi, M., 2008. *Sens. Actuators B* 134, 496–501.
- Bronzino, J.D., 1995. In: Bronzino, J.D. (Ed.), *The Biomedical Engineering Handbook*. CRC Press, Florida, pp. 201–212.
- Clark, J.W., 1998. In: Webster, J.G. (Ed.), *Medical Instrumentation: application and design*. John Wiley & Sons, New York, pp. 183–232.
- Corbett, S.E., 1985. *Electrode Cap*, US 4,537,198.
- Dornhege, G., Millan, J.R., Hinthrbeger, T.J., McFarland, D., 2007. *Toward Brain-Computer Interfacing*. The MIT press, 200, 2007, Boston, 1–8.
- Farwell, L.A., Donchin, E., 1988. *Electroencephalogr. Clin. Neurophysiol.* 70, 510–523.
- Hilt, J.Z., Gupta, A.K., Bashir, R., Peppas, N.A., 2003. *Biomed. Microdevices* 5 (3), 177–184.
- Kandel, E.R., Schwartz, J.H., 2000. *Principles of Neural Science*. McGraw-Hill, New York.
- Kingsley, S.A., Sriram, S., Pollick, A., Marsh, J., 2004. *Proc. SPIE* 5317, 158–166.
- Klem, G.H., Luders, H.O., Jasper, H.H., Elger, C., The International Federation of Clinical Neurophysiology, 1999. *Electroencephalogr. Clin. Neurophysiol. Suppl.* 52, 3–6.
- Ko, L.W., Tsai, I.L., Yang, F.S., Chung, J.F., Lu, S.W., Jung, T.P., Lin, C.T., 2009. In: Koppen, M., Kasbov, N., Coghill, G. (Eds.), *Advances in Neuro-Information Processing*, Pt II. Springer-Verlag Berlin, Berlin, pp. 1038–1045.
- Kondraske, G.V., 1986. In: Bronzino, J.D. (Ed.), *Biomedical Engineering and Instrumentation*. PWS Publishing, Boston, pp. 138–179.
- Maggi, L., Piccini, L., Parini, S., Andreoni, G., Panfilii, G., 2008. *Biosignal acquisition device - A novel topology for wearable signal acquisition devices*. *Biosignals 2008: Proceedings of the First International Conference on Bio-Inspired Systems and Signal Processing*, Vol II, 397–402.
- Matthews, R., McDonald, N.J., Anumula, H., Woodward, J., Turner, P.J., Steindorf, M.A., Chang, K., Pendleton, J.M., 2007. *Foundations of Augmented Cognition*, Proceedings, vol. 4565, pp. 137–146.
- Neuper, C., Müller, G.R., Kubler, A., 2003. *Clin. Neurophysiol.* 114 (3), 399–409.
- Ng, W.C., Seet, H.L., Lee, K.S., Ning, N., Tai, W.X., Sutedja, M., Fuh, J.Y.H., Li, X.P., 2009. *J. Mater. Process. Technol.* 209 (9), 4434–4438.
- Osada, Y., Gong, J.P., 1998. *Adv. Mater.* 10, 827–837.
- Paxton, A.R., 2006. *Modeling of an Electroactive Polymer Hydrogel for Optical Applications*. AUT University Press.
- Pfurtscheller, G., Flotzinger, D., Kalcher, J., 1993. *J. Microcomput. Appl.* 16, 293–299.
- Pfurtscheller, G., Neuper, C., Müller, G.R., Obermaier, B., Krausz, G., Schlögl, A., Scherer, R., Graimann, B., Keinrath, C., Skliris, D., Wörtz, M., Supp, G., Schrank, C., 2003. *IEEE Trans. Neural Syst. Rehabil. Eng.* 11 (2), 177–180.

- Richter, A., Paschew, G., Klatt, S., Lienig, J., Arndt, K.F., Adler, H.J.P., 2008. *Sensors* 8 (1), 561–581.
- Sellers, E.W., Turner, P., Sarnacki, W.A., McManus, T., Vaughan, T.M., Matthews, R., 2009. In: Jacko, J.A. (Ed.), *Human–Computer Interaction, Pt II—Novel Interaction Methods and Techniques*. Springer-Verlag Berlin, Berlin, pp. 623–631.
- Silva, A.F., Gonçalves, F., Ferreira, L.A., Araújo, F.M., Mendes, P.M., Correia, J.H., 2008. *Proc. MME 2008*, Aachen, Germany, September 28–30, pp. 327–330.
- Silva, A.F., Gonçalves, F., Ferreira, L.A., Araújo, F.M., Mendes, P.M., Correia, J.H., 2010. *Mater. Sci. Forum* 636–637, 1548–1554.
- Taheri, B.A., Knight, R.T., Smith, R.L., 1994. *Electroencephalogr. Clin. Neurophysiol.* 90 (5), 376–383.
- Winters, J.M., Wang, Y., 2003. *IEEE Eng. Med. Biol. Mag.* 22 (3), 56–65.
- Wolpaw, J.R., Birbaumer, N., Mcfarland, D.J., Pfurtscheller, G., Vaughan, T.M., 2002. *Clin. Neurophysiol.* 113, 767–791.
- Yates, D., Lopez-Morillo, E., Carvajal, R.G., Ramirez-Angulo, J., Rodriguez-Villegas, E., 2007. *Conf. Proc. IEEE Eng. Med. Biol. Soc.* 2007, 5282–5285.