

Surveillance and Control of the Yarn Input Tension on Circular Weft Knitting Machines: New Approaches

André Catarino

Ana Maria Rocha

João L. Monteiro, IEEE member

Filomena Soares

University of Minho

Textile Engineering Department,
Campus Azurém, 4810-058 Guimarães,
PORTUGAL

whiteman@det.uminho.pt

amrocha@det.uminho.pt

University of Minho

Industrial Electronics Department,
Campus Azurém, 4810-058 Guimarães,
PORTUGAL

joao.monteiro@dei.uminho.pt

fsoares@dei.uminho.pt

Abstract– The Yarn Input Tension - YIT is one of the most important parameters in weft knitting industry. This parameter must be maintained between limits in order to produce knitted fabric without faults. However, YIT is not the only parameter to control and monitor for preventing faults. The knitting elements and the knitting machine itself should be monitored to improve productivity and quality. The monitoring of the YIT can be used to detect the faults and at the same time controlled inside tight limits to prevent machine's premature stop due to yarn break .

This paper will present the recent developments made for monitoring and control the YIT. A surveillance system will be presented, a low cost force sensor will be suggested to substitute the present industrial solutions, and a new actuator for control of the YIT will be introduced.

Keywords: Knitting Machines, Signal Processing, Sensors, Actuators, Fault Detection

1 Introduction

The process of producing weft knitted fabric is rather simple. It involves at least one yarn, needles with a way of interlacing one loop in the previous one (like a latch), equipped with a butt, cams that guide the needles for their up and down movement, and one engine for keep moving the needles. This process can however became a bit more complicated when one intends to produce special structures, but for producing jersey it is just like it was explained.

Speaking exclusively about modern circular knitting machines, several yarns are simultaneously used (up to 96), which allows to produce in one single rotation of the needles cylinder 96 rows (courses) of knitted fabric. The only purpose is to increase the productivity of the knitting machine. With that goal in mind, intensive research was made in order to maximize the relation between the size of the needles cylinder, rotation speed, cam geometry and needles width [14,15] and the best relationship was established.

Working at this rates will demand for a very tight control of the knitting process, namely for the forces applied to the yarn. One of the most important parameters is the *Yarn Input Tension – YIT*, which needs to be maintained within certain limits. This is explained by the effect of Amonton's

law applied to successive needles inside the knitting zone pulling the same yarn [14,15]. The result is the exponential multiplication of the YIT which can exceed the yarn's mechanical limit and thus produce the yarn break. For this purpose, a significant number of solutions are commercially available which control the amount of yarn fed, depending the solution if the yarn feeding is continuous or intermittent and combine a feeding system with a yarn break detector [2,3,4].

On the other hand, today's demands on production require the knitting machines to work as much time as possible, thus maximizing their productivity. This non-stop activity produces an accelerated ageing of the knitting elements, namely, the needles. At the limit the needles will become damaged or will break and thus a fault will be produced. If the fault is not detected, several meters of damaged knitted fabric will be made. In order to avoid this, some solutions exist using two different approaches: by inspecting the knitted fabric (through optical devices) and monitoring the knitting elements (by magnetic sensor or needle detectors) [3,4,5,6,7,8]. However these are not the only causes for the faults and thus these approaches do not detect all kind of situations.

Also important for planning and scheduling is the knowledge of the productivity of the knitting machine: number of hours stopped, speed, knitted fabric production in kilograms, etc. Modern knitting machines provide this kind of information, however it was already stated that an integrated system should also contain also information concerning the YIT, faults, number and position of the faults, and other parameters concerning the production, like loop length, yarn linear speed, etc [1].

This project deals in particular with the monitoring of the knitting process, in order to detect and identify faults, and if possible, to forecast the faults. With this goal in mind, a different approach was selected, by directly inspecting the yarn input tension – YIT [14]. The research made already proved that it is possible to detect all the faults that was produced and sooner than the commercial solutions [13]. It is also possible to use advanced statistical techniques to automatically locate the fault with high precision and accuracy, as well is possible to identify the cause of the fault [11,12,14]. At the same time, the project includes the research for a new method of controlling the YIT, which would be less expensive than the present ones, in particular when the feeding of the yarn is not continuous. The following sections will present the advances made on

the different stages of this project, by presenting the monitoring system, some results of the techniques used, a low force sensor developed and the actuator chosen in order to accomplish the objectives drawn for the project.

2 The Surveillance System

This section will present the surveillance system used for monitor the knitting process through the *YIT*. The system is composed by a set of sensors and conditioning systems and one application that controls the hardware.

2.1 The Conditions of the Experiments

The knitting machines used for the experiments were: a sample making circular weft knitting machine with one positive feeding system, one cam, 168 needles and sinkers, 3.75" diameter cylinder, with speeds up to 200 rpm; and one industrial weft circular knitting machine with 36 positive feeding systems, 36 cams, 756 needles and sinkers, 12" cylinder diameter, and a top speed of 45 rpm.

The raw material used was 100% cotton yarn, 100% spun polyester yarn, 50/50 % cotton/polyester spun yarn, and polyester continuous filament yarn.

It was also considered several variables, namely: the speed, loop length, knitted structure, types of faults, take-off rates, and other properties related with knitted fabric production. However, in this paper only some examples will be shown.

2.2 The Measurement System

The measurement system is based on a force sensor, assembled close to the feeding zone, encoders and an optical sensor. The force sensor is made of strain gages and was designed to be used with forces up to 200 cN, and for industrial knitting speeds, which means acquiring signals from the YIT for more than 2000 needles per second. This is the worst situation possible. The force range allows the sensor to be used even with high mechanical resistance yarns, used on technical textiles. The encoders are used for determine the yarn consumption and calculations about production and also for generating an external sampling rate for the digital system. The optical sensor is used whenever the needles' cylinder vertical axis is not available, which is common on industrial knitting machines. The assembling of the measuring system is very simple and does not require structural modifications on the knitting machine.

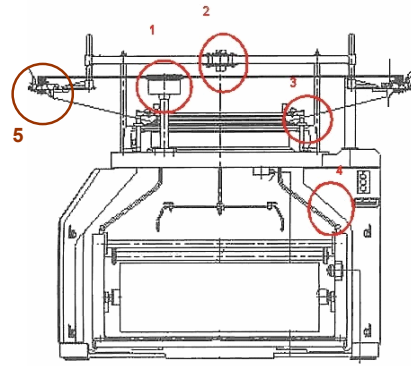

Fig. 1. Assembling of the sensors on an industrial knitting machine.

Fig. 1 shows how the sensors are assembled on a knitting machine: (1) and (2) are the places where the encoder for sampling is assembled, depending if the vertical axis is available, (3) is the place where the force sensor is located, and (4) is the place where the optical sensor is assembled. Another encoder is placed in the feeding system (5) allowing the consumption calculations. This is the most simple system, used when *jersey* is produced. A different structure would require more encoders on other feeders in order to give an accurate measure of the consumption. Likewise, if one intends to detect faults more rapidly it would be necessary to install more force sensors around the cylinder. However, one force sensor is enough to detect the faults in the knitting elements.

The sensors are connected to a conditioning system which is programmable by software and allows to modify the measuring range from 0-10 cN up to 0-200 cN. It is also possible to change the anti-aliasing filter from 250-2000 Hz for the cut-off frequency as well as the offsets through software. This conditioning system is connected to a data acquisition board from National Instruments, and the software developed with LabVIEW allows the communication with the conditioning system.

2.3 The Monitoring Software

The monitoring software is called *MonitorKnit* and it is one part of the main application, called *KnitLAB*. This application is a workbench where several analysis can be made, which includes the measurement system programming, sensor calibration, spectral analysis, digital filtering, several statistical tools (mean tests, anova) correlation, etc. The application is used primarily to analyse the waveform of the YIT and develop the tools that are presently available in the *MonitorKnit* software, which is the focus of this section.

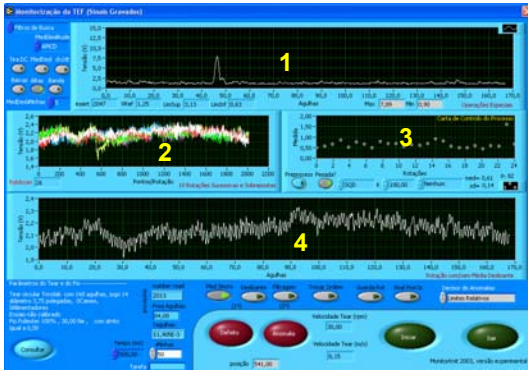

Fig. 2. MonitorKnit in surveillance mode.

The present version includes four graphical areas, as Fig. 2 shows: (1) is the resulting waveform when some specific algorithm for fault detection is used; (2) represents the ten more recent YIT cylinder rotations acquired; (3) represents a process control chart; and (4) represents the currently acquired YIT rotation, which can be subjected to some simple operations that proved to be very useful for detection of faults and forecasting. The application is still under improvements, namely on the layout and also for including new tools for fault detection that were developed meanwhile.

2.4 Fault Detection

When a fault occurs during production due to a damaged needle, the result is a sudden decrease on the YIT. This can be easily observed, however it can not be misinterpreted with an increase or decrease due to friction, which also frequently happens.

With the purpose of automatically detecting the faults, two different approaches were studied [18]: The analysis by means of a single value and the analysis of the entire waveform. Both approaches present advantages and drawbacks. The use of one single value to represent one entire course can be very valuable, since one can use the process control charts to easily monitor the behaviour of the knitting machine. The experiments made showed that this approach allows to easily distinguish a fault during

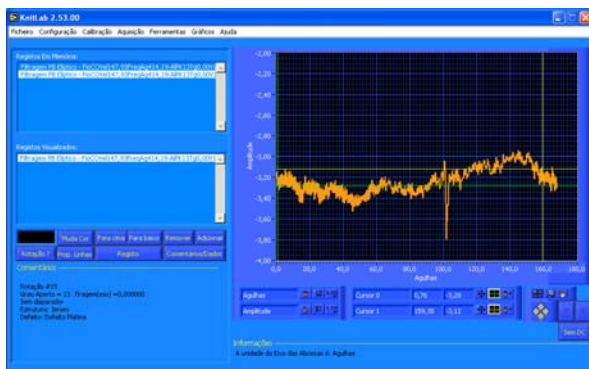

Fig. 4. Missing sinker on Tricolab, for cotton yarn at 150 rpm (~0.75 m/s). The application is KnitLAB.

production as Fig. 3 illustrates. The problem of this

approach is that it does not allow to know where happened the fault. If one knows where the problem is, one can drastically reduce the time for repair.

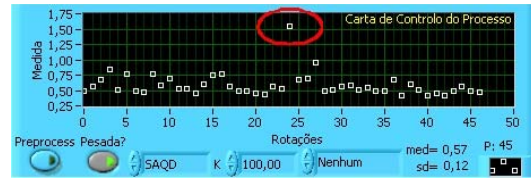

Fig. 3 Process control chart example with a fault present (broken needle).

The second approach involves two basic techniques: one using the synchronized averaged YIT, and the other uses matched pattern techniques. The two complement themselves. It is advisable to use the synchronized averaged YIT waveform since it will absorb the intrinsic variability of the YIT (as (2) shows in Fig. 2) and it will show the waveform free of random effects. It is particularly useful when a fault is permanent. Its accuracy and precision is of one needle, which is excellent. Moreover, when an abnormality occurs this waveform can be used to forecast a fault, because the effect will be persistent. Unfortunately, when one needle occasionally produces one fault, this technique does not allow the detection, because the fault is absorbed.

The matched filter techniques, by choosing a proper template allow to detect this kind of fault. From the different techniques attempted, the one with best results was *AMCD* (Average Magnitude Cross-Difference) [16,17]. The accuracy and precision are still excellent, and it is quite easy to build a decision module to detect the fault. Also, the random variability expressed before is eliminated. However, the forecasting properties are not so evident with this technique.

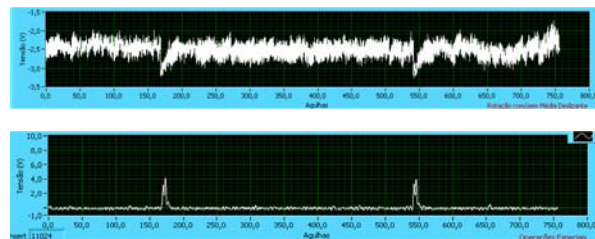

Fig. 5. Regular YIT waveform (up) and resulting AMCD (down), for cotton yarn and in an industrial knitting machine at industrial speeds.

These techniques are being further improved, in order to build the final version of the *MonitorKnit*. However, it should be noted that the system is already at work and with positive results.

3 The problem of the yarn break detectors

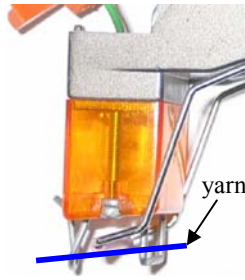

Fig. 6. Yarn break detector detail.

Due to the problems related with the exceeding force when the yarn is pulled by the needles during the knitting cycle, yarn break detectors were introduced. By detecting the yarn break it would be possible to avoid the fall of the knitted fabric, since the knitting machine would stop immediately. Later, this kind of detectors were assembled together with the positive yarn feeding system [3], the system most used in the industry. The yarn break detector is based on the resulting force from the sum of the weight of a metal bar against the yarn when it traverses the path where this metal piece is placed (Fig. 6). When the resulting force between the yarn and the bar weight becomes below a limit, the small metal bar falls and closes a circuit, thus stopping the machine. This is already a way of measuring the YIT. The problem is that this system does not give the value of the YIT and at the same time introduces significant variations when sudden changes occur, due to its dynamical response time. In fact, if one uses this kind of detector together with the surveillance system it will produce many erroneous detections of faults, as Fig. 7 illustrates. In this case, for a 100% cotton yarn and at a very low speed, a sudden decrease similar to a damaged needle was observed.

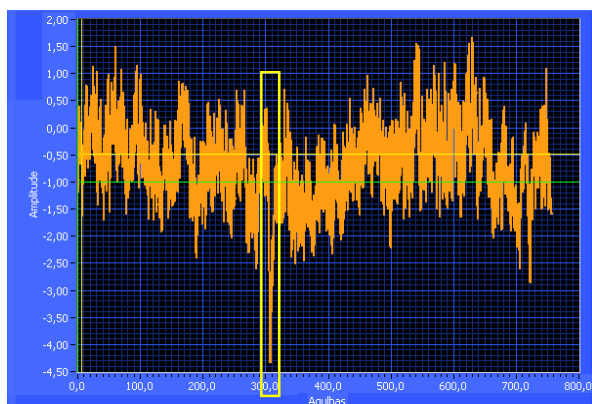

Fig. 7. Potential effect of yarn break detector on YIT. The representation is from KnitLAB and extracted from the industrial knitting machine.

After inspecting the knitted fabric, no fault was detected. At the same time by eye inspection one can

easily see the metal bar producing important angular oscillations which later will be reproduced on the YIT.

3.1 Solutions for the problem – Low Cost Force Sensor

The solution of using one force sensor like the one described in section 2.2 is not economically feasible (unless deactivating the yarn break detector where the force sensor is assembled), so a different kind of approach for a force sensor should be explored. The YIT is important for the technician for fine tuning the knitting machines, thus he uses a *tensiometer* to confirm for each yarn if the tension is adequate, which is time consuming. The industry manufactures started to replace this yarn break detector by optical sensors, with no contact with the yarn, nevertheless the YIT still remains unknown. The solution encountered was the indirect measure of the force by the detected deflection of a small metal bar by means of an inductive sensor. Fig. 8 illustrates the second version of the developed prototype. It was also developed a measurement system, based on a microcontroller 8051 which allows the technician to know the present value of the YIT where this sensor is connected. At the same time there is a direct path to the surveillance system in order to analyse the waveform of the YIT when this sensor is used, and it was found that it also can detect some of the faults produced by damaged needles [10]. However, the dynamical response is not so good as the strain gages one. It is worth to note though that the dynamical response depends from the arrangement of the bar and its mechanical properties, so with a different bar, the response can very well be improved.

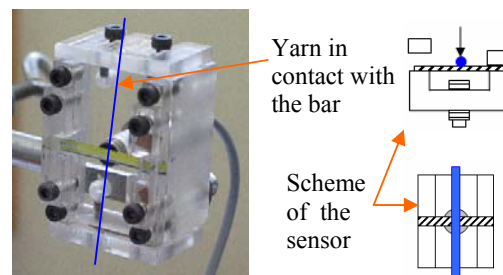

Fig. 8. Developed low cost sensor, for replacement of the yarn break detector.

3.2 Characterisation of the Force Sensor

A special arrangement allowed to maximize the dynamical response of this sensor. The resulting step response is illustrated on Fig. 9. For this particular arrangement, the force range was from 0-0,015 N and the natural frequency around 500 Hz.

This arrangement corresponds to the following expression:

$$r_L \approx \frac{FL^3}{107EI} \quad (1)$$

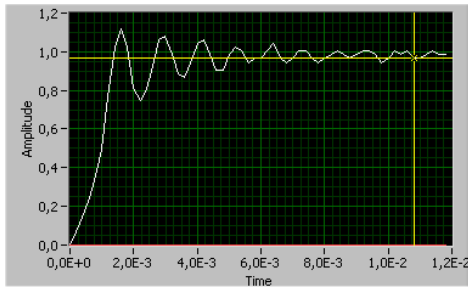

Fig. 9. Dynamical response of the low cost sensor.

Where F is the force applied, L the bar length, and EI the flexural rigidity, which depends on the bar nature. The $r_{L/2}$ means the bar deflection in m^{-3} . This deflection is measured by the analog inductive sensor which is capable to measure deflections of m^{-6} . Different assembling for the metal bar allows other force ranges and dynamical responses. Using a laser sensor, research was made in order to confirm the linearity between the force applied and the deflection as well as the resulting voltage from the sensor. As it is shown in Fig. 11, there is in fact a linear relation between deflection and the sensor's output, as well as for the relation between deflection and applied force. The constant is due to the initial distance from the analog sensor to the metal bar which introduces an offset.

This offset can be used to detect a possible permanent damage on the metal bar, since the forces are very small and defective use of the bar can result in permanent damage.

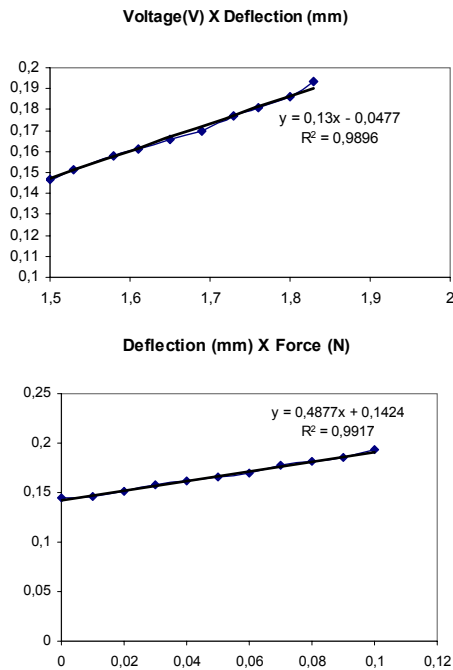

Fig. 11. Relations between deflection and sensor's output and force.

The comparison between the theoretical expression (1) and the experiments made are represented on Fig. 12.

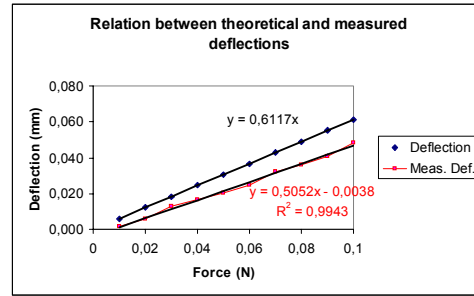

Fig. 12. Relation of theory and practical deflections. In blue the theoretical expression, and in red the measured deflection

Although there is a great proximity between theoretical (formula) and practical measurement of deflection, a slope difference exists. However, since the force was not applied exactly at $L/2$, this situation can possibly explain the detected slope difference. Nevertheless, there is a remarkable resemblance between the mathematical model of the deflection and the real results.

4 Yarn Input Tension Control

Previous sections have stressed the importance of controlling the YIT, not only for producing the knitted fabric, but also for detecting the faults by using the YIT monitoring approach, since it is more effective than the ones presently used. The system with more success is the positive feeding system, known as *trip-tape*. This system feeds the yarn at a constant speed and thus it controls in a certain way the YIT. However, this system requires continuous feeding of the yarn, and there are several machines that produce knitwear with intermittent feeding, like jacquard machines. The commercial manufacturers developed other electronic feeding systems that simulate the positive feeding, however they are very expensive. The objective in this stage was to attempt to develop an actuating system that was capable to control the YIT (not the yarn feeding length), but at the same time constituting a low cost solution.

4.1 The Actuating System

The proposed system is based on an electromagnetic arm, like Fig. 10 shows. The principle is similar to VCM motors, since one end of the arm has copper yarn winding and this end is fixed on an axis and surrounded by a

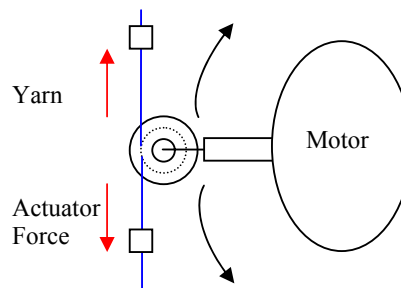

Fig. 10. Actuator System.

magnetic case. When a current is supplied, the arm moves

in one or the other way depending if the current is positive or negative. For that purpose a conditioning system was developed which allows the control of the arm only in an upwards movement, or it allows both upwards and downwards movement. The resulting system presents a rising time from one to the other end of less than 30 ms.

Due to its nature, the actuator works like a spring: as soon as a reference voltage (converted to current) is applied the arms moves from the rest position into the final one. This means an upward movement. This movement can be counteracted by a force in the opposite direction. It is possible to establish a compromise between the tendency to go up and the opposite force. This is much like the same behaviour of the spring which is extensively used in flat knitting machines and also some circular ones, however the response times are very different. The adjustment of the force on this particular actuator is related with the reference voltage.

4.2 Results of the Actuating System

When the actuator is connected into the knitting machine, and correctly adjusted, without any kind of other tension control system, one can produce knitted fabric without any fault, which means that this actuator can affectively control the YIT. The following image show the effect of the actuator when a negative control system is also used (a two disk plate). As it can be seen in Fig. 13, the actuator can control the YIT and if eventually a fault occurs, it is detectable, just like the positive feeding system. In orange a rotation without a fault and in white a rotation with a broken needle. The knitting machine can also produce knitted fabric without any fault even for high values adjusted on the negative YIT controller, since this actuator is able to compensate that exceeding offset force.

Another advantage of this actuator is its dimensions which are excellent, since it does not require a significant space on the knitting machine.

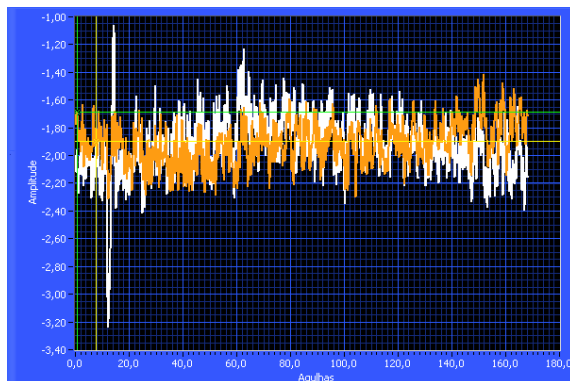

Fig. 13. Result of the actuator controlling the YIT, for a situation with no fault and with a fault.

5 Future developments

As it was seen during the presentation of this paper there are many improvements to be made: The monitoring system is the most advanced part of the project, and at this time the authors are developing the pattern recognition

stage that will be the final phase. Some experiments were already made using discriminant analysis with excellent results.

The low cost sensor needs further improvements in order to obtain a better dynamical response. A new prototype is under development.

The actuator is also under investigation, namely for a tighter control of the YIT. Experiments are being conducted using PID techniques to improve the control of the YIT. However, other approaches can be assumed to be also explored. These are some of the future developments in this project.

6 Conclusions

This paper presented the research conducted in the area of signal processing and control of YIT on weft knitting machines, in particular monitoring the YIT for fault detection, spatial location of the fault and identification. Based on the results obtained so far, the authors believe that these approaches, will contribute for more productive machines and less non conform knitted fabric. The approaches presented – for YIT measurement (by using direct or indirect measurement of the force) and control (by replacing spring compensators by VCM actuators) are low cost ones, which benefits the manufacturer and can introduce a new concept on knitting machines, by using a full integrated information system with all sensing devices inter-connected.

Acknowledgement

The authors wish to thank the support for this project from University of Minho and FCT - Fundação para a Ciência e Tecnologia, which is funding this project under program POSI/SRI/39824/2001.

References

- [1] G. Buhler, L. Pestel, H. Hait, “Requirements in regard to future circular knitting assurance systems- Practical trial with a future-oriented monitoring system”, *Melliand textilberichte*, 1, 1994, p 39-42
- [2] T. Push, I. Wunsh, R. Seifert, P. Offermann, “Fine structure of yarn tension on large-diameter circular knitting machines”, *Melliand textilberichte* 1-2, 1997, p 52-55
- [3] H. Behr, “Accessories for circular and flat knitting machines”, *Knitting Technology*, 1996, Vol. 18, 4, p. 184-189
- [4] J. Bauer, “Positive yarn feed on knitting machines”, *Knitting Technology*, 1996, Vol 18, 4, p. 190-193
- [5] Needle Detector NW from Memminger-IRO, reference 335.905.001.07 DSNL/5, official website <http://www.memminger-iro.de/>
- [6] Digital Needle Sensor Type 4020, Protechna, official website http://www.protechna.de/e/nadtast_dd.htm

- [7] Fabric Scanner LMW 3, Memminger-IRO, reference 040.905.000.01 DUDD/40, official website <http://www.memminger-iro.de/>
- [8] Yarn detectors OFW/UFW, Memminger-IRO, official website <http://www.memminger-iro.de/>
- [9] A. P. Catarino, A.M. Rocha, J. L. Monteiro, "Monitoring Systems for fault detection on circular knitting machines through yarn input tension", in Proceedings of the ICOM 2003 – International Conference on Mechatronics, ISBN 1 86058 420 9, pg 465-470
- [10] André Catarino, Ana Rocha, João Monteiro, "Low Cost Sensor for the Measurement of Yarn Input Tension on Knitting Machines", in proceedings of the ISIE 2003 – International Symposium on Industrial Electronics, ISBN 0-7803-7912-8
- [11] André Catarino, Ana Rocha, João Monteiro, "Monitoring Knitting Process through Yarn Input Tension: New Developments", in proceedings of IECON 2002, ISBN 0-7803-7475-4
- [12] A. Catarino, A. M. Rocha, J. Monteiro; "Automatic Fault Identification in Knitting Machines", in Proceedings of Signal Processing, Pattern Recognition and Applications 2001 IASTED International Conference, pp.5-10
- [13] M. Araújo, A. Rocha, H. Hong, A. Catarino, "Towards the Automatic Control of Sewing and Knitting Operations", in Proceedings of World Automation Congress 2000, pp. 636-641
- [14] A. Catarino, Dinâmica da Tricotagem: Estudo da Dinâmica da Tensão de Entrada do Fio e sua Aplicação em Controlo de Qualidade, Msc Thesis, University of Minho, 1998
- [15] David J. Spencer, Knitting Technology, 2nd Ed., Pergamon Press: 1989
- [16] E. C. Ifeachor and B W. Jervis, Digital Signal Processing a practical approach, 2nd edition, Prentice Hall, Harlow, 2002, pg 877-887
- [17] B.U. Kohler, C. Hennig, R. Orglmeister, "The Principles of Software QRS Detection", IEEE Engineering in Medicine and Biology, January/February, 2002, pg 42-57
- [18] Catarino A., Rocha A., Monteiro J. L., Soares F., "Techniques for Unveiling Faults During Knitting Production", in proceedings of IEEE ISIE 2004 – IEEE International Symposium on Industrial Electronics, ISBN 0-7803-8305-2